

KIEN1005 Industrial Ethernet Switch User's Manual

KYLAND Telecom Technology Co., Ltd.

9/2006

KIEN1005 Industrial Ethernet Switch User's Manual

Copyright © 2005 KYLAND Telecom Technology CO., LTD.

All rights reserved.

No part of this documentation may be excerpted, reproduced, translated, annotated or duplicated, in any form or by any means without the prior written permission of Kyland Corporation.

Publisher: Kyland Telecom Technology Co., Ltd.

Address: P.O.Box 100096, 085, Beijing, China

Website: <http://www.kyland.cn>

Postcode: 100096

Customer Service: +86(10)82900770

Fax: +86 (10)82900780

Email: sales@kyland.cn

Version: V2.0 , September, 2006

Code: e2c01060402

Preface

KIEN1005 is a high performance unmanaged industrial Ethernet switch developed by Kyland for industrial application。 Its high performance switching engine, closed casing design, low consumption fan less heat removal, over-current, over-voltage and EMC protection for power supply input terminal, and excellent EMC protection function of Ethernet RJ45 port enable KIEN1005 to run in a harsh industrial environment and ensure a high reliability to the system。

The *KIEN1005 Industrial Ethernet Switch Uses Manual* mainly introduces the technical principle, performance index, installation and testing of the KIEN1005 industrial Ethernet switch, and provides the reference to users to start, expand and maintain the system. Meanwhile, it applies to the user training and learning for related technical personnel, so it is a practical education material for mass users to learn about the KIEN1005 industrial Ethernet switch.

Main contents are:

Chapter One: Overview and System Features

Chapter Two: Performance Specification and Service Functions

Chapter Three: Hardware Structure

Chapter Four: Field-testing Methods

Appendix A: Twisted-pair Cable and Pin Assignment Rules

Appendix B: Cable Type and Specifications

Appendix C: Glossary

Statement: For continuous update and perfection of the product and technology, the contents of this manual may not be consistent with the actual product, please contact with us about related contents. For the latest information, please visit our website or contact with our local service representative directly。

Safety Notices

This product can provide excellent and reliable performance within its design scope. However, it needs to avoid the damage or destroy by human reasons.

- Read this Manual thoroughly and keep it well for future reference.
- Do not place the equipment next to the source of water and the damp place.
- Do not place anything on the power cable. Please place it somewhere that can not be reached.
- In order to avoid fire, do not tie or pack the cable.
- The connector of the power supply and other equipment connection should be connected firmly and regularly checked.

If the situation below occurs, please power off and contact with our company immediately.

1. Water into equipment;
 2. Equipment is broken or the crust is cracked;
 3. The equipment works abnormally or the performance provided has changed completely;
 4. The equipment gives off odor, smoke or noise.
- Pay attention to the cleanness of the fiber socket and jack. When the equipment operates, do not watch the end-face of the fiber directly.
 - Pay attention to the cleanness of the equipment and clean it with soft cotton cloth if necessary.
 - Do not repair the equipment by yourself unless it is definitely indicated in this manual.

Description of Warning Mark:

This manual uses two kinds of obvious warning marks to prompt users that more attention should be paid during operation. The meanings of these marks as follows:



Warning: The comment after this mark should be paid more attention, the incorrect operation will cause the switch to be damaged seriously or it will cause body injury for the operator.



Caution, Note, Warning and Dangerous: Indicate where more attention should be paid.

Contents

Chapter One System Overview	5
1.1 Overview	5
1.2 Features.....	5
Chapter Two Performance Specification	7
2.1 System Specification.....	7
2.2 Service Port Specification	8
2.3 Service Functions	9
Chapter Three Hardware Structure	10
3.1 System Structure	10
3.2 Switch Structure.....	11
3.2.1 Casing	11
3.2.2 Front Panel.....	12
Chapter Four Field-testing Methods	16
4.1 Self Testing.....	16
4.2 Ethernet Port Testing.....	16
4.3 Fiber Port Testing.....	17
Appendix A: Twisted-pair Cable and Pin Assignment Rules	18
Appendix B: Cable Type and Specifications	21
Appendix C Glossary	22

Chapter One System Overview

1.1 Overview

KIEN1005 series contains two models: KEIN1005-5T and KIEN1005-1S (M) -4T

KIEN1005-5T offers five adaptive TP ports of 10/100BASE-T/TX, which can be configured to 10BASE-T or 100BASE-TX and half-duplex or full-duplex mode. KIEN1005-1S (M) -4T provides one full-duplex fiber port of 100Mbit/s and four TP ports of 10/100BASE-T/TX, which can be configured to 10BASE-T or 100BASE-TX and half-duplex or full-duplex mode. The switch can be connected by plug-and-play to save start-up time and offers 18-36V DC power supply input ensuring a high reliability.

1.2 Features

1. High performance industrial Ethernet switch

10/100Base-T/TX adaptive Ethernet ports (full/half-duplex), auto MDI/MDI-X connection.

100Base-FX full-duplex fiber port, single mode or multimode
Broadcasting storm protection.

2. Industrial power supply

Industrial DC24V (DC18V ~ 36V) input.

Protection against over-current and over-voltage.

Protection against reverse polarity connection.

Electromagnetic compatibility protection, industrial level four.

3. Industrial casing design

Highly-effective fan less heat dissipation, with operation temperature range of -40°C ~ +75°C.

Closed aluminum casing, IP40 protection class for harsh industrial application.

Easy DIN-Rail mounting.

Chapter Two Performance Specification

2.1 System Specification

The system specification of the KIEN1005 Industrial Ethernet Switch is shown in Table 2-1.

Table 2-1 System Specifications

Specifications	KIEN1005-5T	KIEN1005-1S (M) -4T
10/100Base-TX	5 x RJ45	4 x RJ45
100Base-FX		1 S (M)
System	Standard: IEEE802.3 、 IEEE 802.3x 、 IEEE 802.3u 、 IEEE 802.1p、 IEEE 802.1Q Store-and-forward switching rate: 148810 pps Max filter rate: 148810 pps Switching mode: store-and-forward System switching bandwidth: 1.0G Electromagnetic Interference : EN55022 Electromagnetic compatibility: EN50082-2(level four, class A).	Standard: IEEE802.3、 IEEE 802.3x、 IEEE 802.3u 、 IEEE 802.1p、 IEEE 802.1Q Store-and-forward switching rate: 148810 pps Max filter rate: 148810 pps Switching mode: store-and-forward System switching bandwidth: 1.0G Electromagnetic Interference : EN55022 Electromagnetic compatibility: EN50082-2(level four, class A).
TP port	Physical Interface: RJ-45 socket, shielded RJ-45 port: 10Base-T/100Base-TX, auto-negotiation Interface standard: IEEE802.3 Transmission Distance: <100m	Physical Interface: RJ-45 socket, shielded RJ-45 port: 10Base-T/100Base-TX, auto-negotiation Interface standard: IEEE802.3 Transmission Distance: <100m
Fiber port		Optical power: >-13dbm(SM) >-20dbm(MM) Sensitivity:

		<p><-28dbm(SM) <-35dbm(MM)</p> <p>Wavelength : 1310nm(SM)</p> <p>1550nm(SM) 1310 nm (MM)</p> <p>Transmission distance: 20 ~ 80Km(SM) <2Km(MM)</p> <p>Connector: SC/FC</p> <p>Transmission rate: 125Mbps</p>
Power supply	<p>Power input: DC24V (DC 18V ~ 36V)</p> <p>Power consumption: <6W</p> <p>Over-current protection: built-in</p>	<p>Power input: DC24V (DC 18V ~ 36V)</p> <p>Power consumption: <6W</p> <p>Over-current protection: built-in</p>
Dimensions(W x H x D)	36.5 x 120 x 90(mm)	36.5 x 120 x 90(mm)
Ambient conditions	<p>Operating temperature: -40℃ ~ 75℃</p> <p>Storage temperature: -45℃ ~ 85℃</p> <p>Relative humidity (non-condensing): 10% ~ 95%</p>	<p>Operating temperature: -40℃ ~ 75℃</p> <p>Storage temperature: -45℃ ~ 85℃</p> <p>Relative humidity (non-condensing): 10% ~ 95%</p>

2.2 Service Port Specification

1. 10/100Base-T/TX adaptive RJ45 Ethernet ports. Each port is adaptive to 10/100M and full/half-duplex mode. The maximum Transmissions distance is 100m Max.
2. 100Base-FX fiber port, single mode or multimode, Max throughput of each pair optical fiber is 100Mbps,complies with IEEE802.3/802.3U/802.3X.
3. 100Base-FX fiber port, single mode or multimode, throughput of each pair optical fiber is 100Mbps Max, it is enforced to 100M full-duplex mode and complies with IEEE802.3/802.3U/802.3X.
4. RJ45 ports indicators: Yellow for rate, ON: 100M; OFF:10M. Green for link state, ON: valid connection; BLINKING: active network; OFF: no connection.

2.3 Service Functions

1. LED Indicating

The LEDs indicate the port status correctly including transmission rate, link status and system status.

2. 802.1p Prioritization

KIEN1005 conforms to 802.1p, which is used the most widely in LAN environment. The end-users of KIEN1005 can make use of this function to configure the port-based prioritization when 802.1p is not supported at user's end and different priority is necessary for different ports' services. Only the data package without Prioritization in the Packet in the ports can be affected by this function. THE 5th port of KIEN1005 supports 2 levels (high, low) prioritization.

3. Layer-2 Switching

Switches work in two ways: Cut-Through and Store-and-Forward. In Cut-Through, a data packet is immediately relayed further after detecting the target address; in Store-and-Forward, a data packet is first read-in completely and checked for errors before the switch relays the same. KIEN1005 employs Store-and-Forward that is a switching mode widely used.

4. Broadcast Storm Control

Broadcast storm is the ceaseless transfer of broadcast frame or multicast frame in bridge, which is caused by loop and will waste much bandwidth. The purpose of broadcast storm control is to optimize the performance of switch network. KIEN1005 supports the broadcast storm based on percentage. With the control percentage, the broadcast flow of KIEN1005 will be monitored and controlled effectively. The switch will filter out the over flow and ensure the flow percentage is normal once the bandwidth of broadcast flow exceed the limit.

Chapter Three Hardware Structure

3.1 System Structure

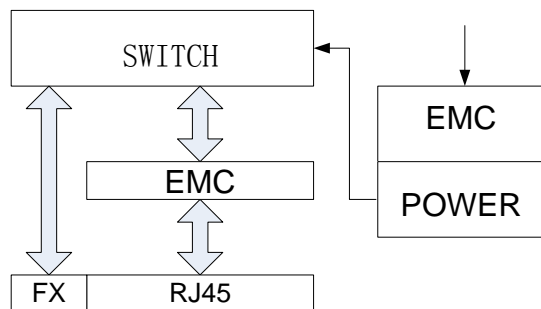

Figure: 3-1 System structure

The system hardware mainly consists of following parts:

1. The switching network controller adopts the high performance ASIC chip technology to provide the layer2 line rate forward for the data packet.
2. The optical fiber interface employs the optical receiving and transmitting integrated module to ensure stable performance.
3. Industrial power supply with protection against over-current and over-voltage.
4. Protection against reverse polarity connection.
5. Industrial level four Electromagnetic compatibility protection of power interface.
6. EMC protection of service interface.

3.2 Switch Structure

3.2.1 Casing

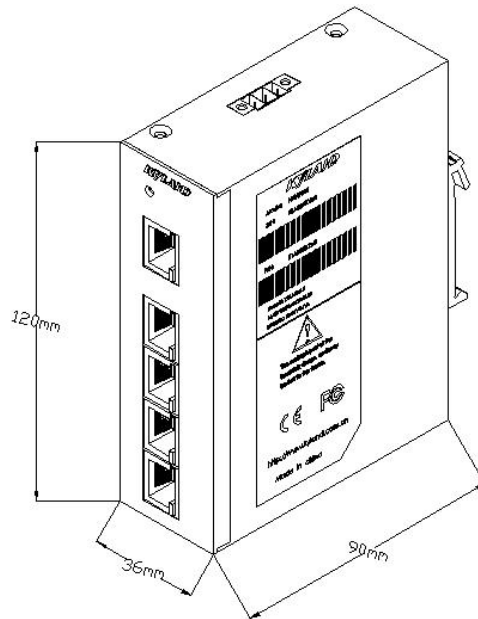

Figure: 3-2 KIE1005-5T

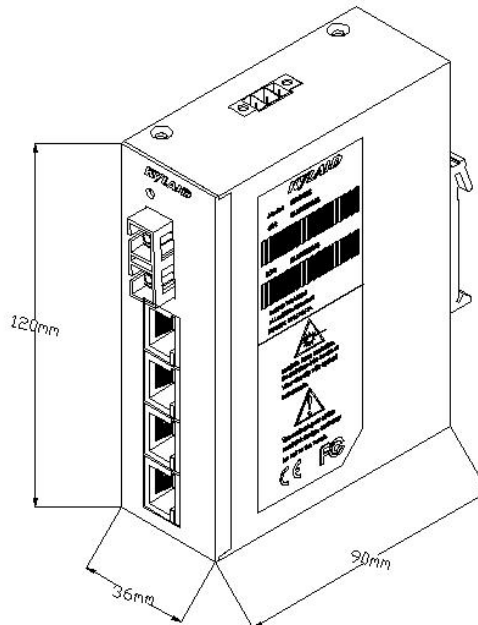

Figure: 3-3 KIE1005-1S (M) -5T

3.2.2 Front Panel

The front panel of KIEN1005-5T has integrated five Ethernet RJ45 ports of 10Base-T/100Base-TX, one power terminal and one indicating light for power supply. Its structure is shown as Figure:

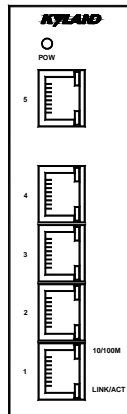

Figure: 3-4 KIEN1005-5T front panel

The front panel of KIEN1005-1S (M) -4T contains four Ethernet RJ45 ports of 10Base-T/100Base-TX, one pair of fiber ports, one power terminal, one indicating light for power supply, and one indicating light for fiber port running status. It is structured as figure:

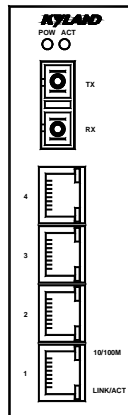

Figure: 3-5 KIEN1005-1S (M) -4T front panel

Optical fiber interface

KIEN1005-1S (M) -4T offers one full-duplex fiber port of 100Base-FX, single mode or multimode, which is numbered as five. Its connector can be SC or FC. The optical fiber interface should be used in pair (TX and RX in pair), where, the TX interface is the optical transmitting

terminal which connects to the optical receiving terminal RX for the optical interface of the remote switching, the RX is the optical receiving terminal which connects to the optical transmitting terminal TX for the same optical interface of the remote switch..

Ethernet RJ45 Port

KIEN1005-5T offers five Ethernet RJ45 ports of 10Base-T/100Base-TX. KIEN1005-1S (M) -4T contains four Ethernet RJ45 ports of 10Base-T/100Base-TX. Each RJ45 port is adaptive and supports auto MDI/MDI-X connection. It can be connected by straight-through/cross-over cable to terminal devices, servers, hubs or other switches. Each port supports IEEE802.3x, so the optimum transmission mode (half-duplex or full-duplex) and data rate (10 Mbps or 100Mbps) will be selected automatically (the connected devices should supports this features too). If the connected devices are not adaptive, the port will send at the correct rate but with default mode of half-duplex.

Power Input Terminal

The KIEN1005 uses the DC24V power supply. It uses the 3.81 mm gap 3-wire phoenix terminal to connect to the power supply. The diameter of the power supply is less than 1.5 mm.

The sequence of the connection is shown in Figureure.3-6. The connection wire and the installation step as follows:

Peel off the crust of the power cable for about 5mm to twist several of exposed copper wires into one bundle;

1. Use the 2.5mm “-” shape screw driver to loose the “power cable lock screw, insert the power cable into the hole at the end of the terminal, screw tightly the “power cable lock screw”;
2. Insert the power supply terminal into the DC socket of the equipment, use the 2.5mm “-” shape screwdriver to screw tightly two “terminal lock screw” to fixedly connect the terminal and the power supply connector.

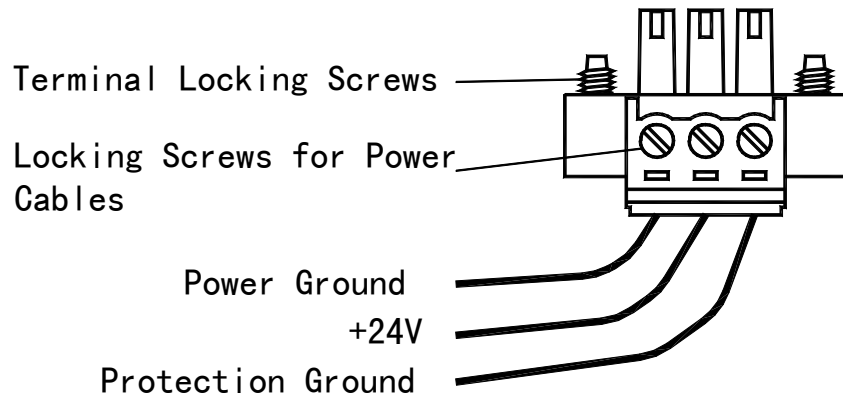

Figure: 3-6 Connection Diagram of DC Power Supply Terminal

LED Indicator

The LED indication light of the KIEN1005 front panel can display the status of the system operation and the port, which make it easy to find problem and troubleshooting. Table 3-1 describes the meanings of the front panel LED indication light.

Table 3-1 Description of LED Indication Light

LED	Condition	Status
System Status LED		
POWER	ON	The power supply is in connection and runs normally.
	OFF	The power supply is not connected or runs abnormally.
Fiber Port LED		
LINK/ACT	ON	Valid connection in port
	BLINKING	Network activity in port
	OFF	No valid connection in port
Ethernet RJ45 Port Status LED		
There are two indicating lights for each RJ45 port, yellow is for port rate and green for link status.		
10M/100M (Yellow)	ON	100M status (100Base-TX)
	OFF	10M status (10Base-T)
LINK/ACT	ON	Valid connection in port
	BLINKING	Network activity in port

(Green)	OFF	No valid connection in port
---------	-----	-----------------------------

Property Setting Switch

There is two bit of property setting switch for the KIEN1005, which are defined as T and F respectively. They are used to configure the rate of fiber port, rate of 5th Ethernet port, and broadcasting storm control ability. The specific relation of position and property is shown as 3-2:

Table 3-2 Relationship Table for Position and Property Setting Switch

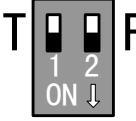
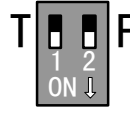
Setting switch position		Property
Position	Logic Position	
	T OFF	Setting switch (T,F) are both OFF, the device is set as default: there are five adaptive RJ45 ports of 10/100 Base-T/TX and Full/Half -Duplex without broadcasting storm control function in Default of KIEN1005-5T Default of KIEN1005-1S(M)-4T is with one half-duplex fiber port of 100M; four adaptive RJ45 ports with 10/100 Base-T/TX and Full/Half duplex without broadcasting storm control function.
	F OFF	
	T ON	Setting switch (T,F) are both ON.KIEN1005-5T is set as five twisted-pair ports of 10/100BASE-T/TX; each port is adaptive, 10/100Base-T/TX and Full/Half duplex automatically. Port of NO.5 has broadcasting storm control function and high priority. KIEN1005-1S(M)-4T is set as one full-duplex fiber port which has broadcasting storm control function and high priority, and four twisted-pair ports of 10/100Base-T/TX. Each port is adaptive, 10/100Base-T/TX and Full/Half duplex.
	F ON	

Chapter Four Field-testing Methods

4.1 Self Testing

All the indicating lights of all service ports will be blinking once in the moment of device powered, to show the port runs normally, afterwards, the relative POW light will be always on.

4.2 Ethernet Port Testing

As showed in the Figure 4-1, the KIEN1005 is powered on to connect any two Ethernet ports with two testing computers with direct link network wires. Send PING command each other. If the hardware of the tested Ethernet ports runs normally, any one computer is able to ping the other correctly without package loss. Also, yellow indicators of corresponding port are on when network cards of computers are in 100M status or off when in 10M status, and green indicators of corresponding ports are blinking. It indicates that the hardware of tested two Ethernet Ports work normally. The same method is used to test all other Ethernet ports (For detailed operation of the PING command, refer to the following examples.).

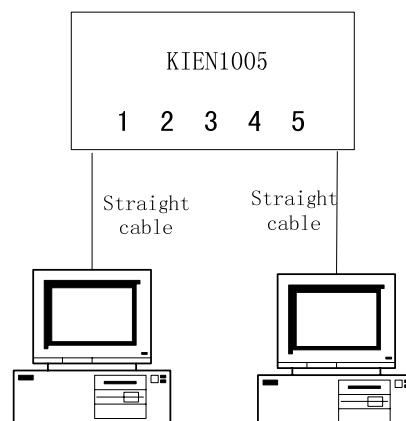

Figure: 4-1 Testing Ethernet ports

4.3 Fiber Port Testing

Use two KIEN1005 switches to build an optical fiber chain network as is shown in the Figure.4-2. Connect any one fiber port of a switch with a testing computer by straight-through cable. Send the PING command each other. If the hardware of the tested fiber ports runs normally, any one computer is able to PING the other without package loss while the LINK/ACT indicator of corresponding fiber port is on. It indicates that the hardware of tested two fiber ports work normally. (For detailed operation of the PING command, refer to the following examples.).

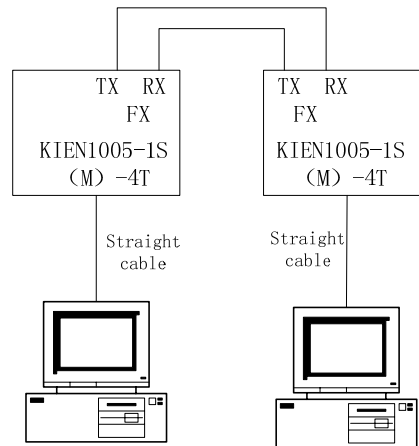

Figure 4-2 Fiber port testing

PING Command :

The IP address of the testing computer 1 is 192.168.100.10 and the 2 is 192.168.100.11. On the testing computer 1, run “cmd” in the WIN2000 operating system or “command” in the WIN98/95 operating system from “Run” in the “Start” menu. Send “ping 192.168.100.11 -l 1000 -t”. (-l means byte number of the sent data package; -t means continuously sending data). On the testing computer 2, run “cmd” in the WIN2000 operating system or “command” in the WIN98/95 operating system from “Run” in the “Start” menu. Send “ping 192.168.100.10 -l 1000 -t”. If switches run normally, the testing computer 1 returns “Reply from 192.168.100.11 : bytes=1000 time<10ms TTL=128” and the 2 returns “Reply from 192.168.100.10 : bytes=1000 time<10ms TTL=128”, and the counted package loss rate is zero checked by the CTL+C

command ten minutes after running.

Appendix A: Twisted-pair Cable and Pin Assignment

Rules

For the 10Base-T/100Base-TX connection, the twisted-pair cable should be in two pairs. Each pair is differentiated by different colors. For instance, the one is green and the other is the green and white interleaved. There should be the RJ-45 connector at both ends of cable.



Warning:

Don't plug the telephone jacket into any one RJ-45 port. Only the twisted-pair which complies with the FCC standard is used. Furthermore, both ends should be RJ-45 connectors.

Figure.A-1 shows how to number the RJ-45 connector, please confirm the consistence of the direction when it is inserted.

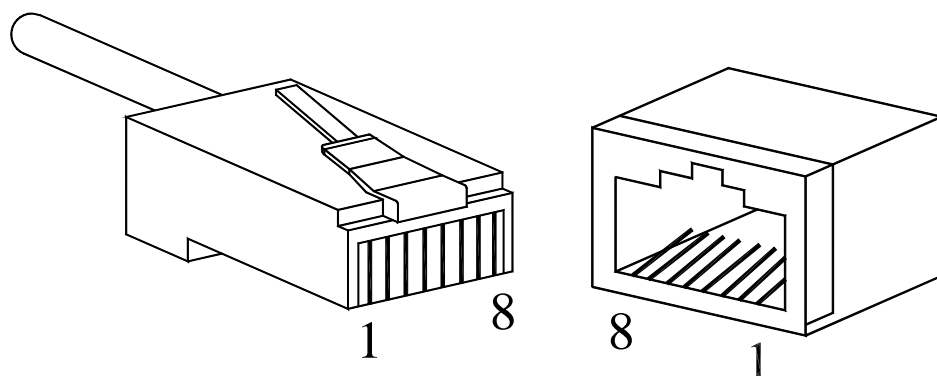

Figure A-1 RJ-45

Pin distribution of 10Base-T/100Base-TX

RJ-45 connection adopts the Unshielded Twisted Paired (UTP) or the Shielded Twisted Pair (STP): the 10Mbps connection adopts the 100ohm of Cat3, Cat4 and Cat5, while the 100Mbps connection adopts the 100ohm of Cat5. Furthermore, keep in mind that the connection length of any twisted-pair should no be more than 100m.

The RJ-45 port supports the automatic MDI/MDI-X operation, and can use the direct connection wire to connect the PC or server, or connect other switches or hubs. In the direct connection wire, pin 1, 2, 3 and 6 are at the same end of the cable and are connected to the pin 1, 2, 3 and 6 at the other end of the connection cable. If it is necessary to connect to the switches or hubs with MDI-X port, it needs to use the crossover wire. For the concrete condition on the 10Base-T/100Base-TX pin assignment, refer to table A-1.

Table A-1 10Base-T/100Base-TX Pin Assignment

Pin	MDI-X signal name	MDI signal name
1	Receiving data + (RD+)	Output data + (TD+)
2	Receiving data - (RD-)	Output data - (TD-)
3	Output data + (TD+)	Receiving data + (RD+)
6	Output data - (TD-)	Receiving data - (RD-)
4, 5, 7, 8	unused	unused

Note: “+” and “-” represent the polarity of cable

Definition for Straight-through Cable from RJ45 (8-pin) to RJ45 (8-pin)

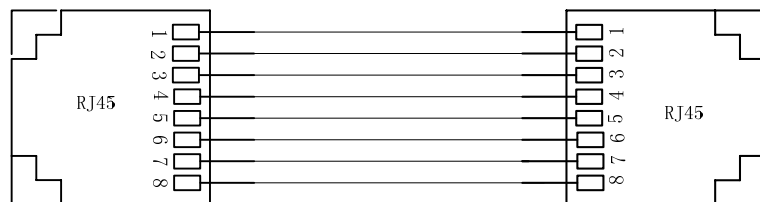

The connection sequence is in turn: Orange-white, Orange, Green-white, Blue, Blue-white, Green, Brown-white and Brown

Figure.A-2 Order of Straight-through Cable

Definition for Cross-over Cable from RJ45 (8-pin) to RJ45 (8-pin)

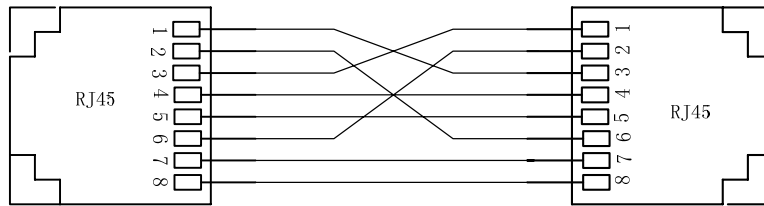

The connection sequence is in turn: Orange-white, Orange, Green-white, Blue, Blue-white, Green, Brown-white and Brown
Green-white, Green, Orange-white, Blue, Blue-white, Orange, Brown-white and Brown

Figure.A-3 Order of Cross-over Cable

Appendix B: Cable Type and Specifications

The type and specification of cable is shown as Figure.B-1.

Table B-1 Type and Specification of Cable

Cable	Type	Maximum Length	Connector
10Base-T	Cat3, Cat4 and Cat5, 100ohm UTP	100m (328 foot)	RJ-45
100Base-TX	Cat5, 100ohm UTP	100m (328 foot)	RJ-45
100Base-FX	50/125 or 62.5/125 μ m core multi-mode optical fiber cable (MMF)	2km (1.24 miles)	SC/FC
100Base-FX	9/125 μ m core single mode optical fiber cable (SMF)	20km (12.43 miles)	SC/FC

Appendix C Glossary

Terminology	Explanation
10Base-T	Twisted-pair standard of Cat3, Cat4 and Cat5 in IEEE specification for 10Mbps Ethernet
100Base-TX	Twisted-pair standard of Cat5 or above in IEEE specification for 100Mbps Fast Ethernet
100Base-FX	Fast Ethernet which uses one pair of multi-mode or single mode optical fiber to transmit.
Adaptive	A characteristic that is automatically configured to adaptive mode for the speed, duplex and traffic control port.
Bandwidth	The information capacity that the channel can transmit. For instance, the bandwidth of the Fast Ethernet is 100Mbps (bit per second) .
Baud Rate	It expresses the signaling rate which is defined as the change times of the status for the electric or optical transmission medium within 1 second.
Bridge	One of network equipments which run on the layer2 in the OSI layer7 model, and it can be connected to the LAN or network segment which uses the same protocol. It presents the automatic network address learning and network configuration function.
Flow Control	It is a congestion control mechanism. The network equipment sends the data to the equipment which has overloaded and causes the port to congest. The traffic control can prevent the data packet from loss and avoid the congestion for the port.
Broadcast	One data packet is sent to all equipments on the network.
Broadcast storm	Restless forward broadcast frame or multicast frame on bridge caused by the bridge ring.

Full Duplex	Use switches to set up the point to point connection among nodes in the LAN and allow them to receive and send data packet at the same time.
Half Duplex	The communication for two nodes can only move toward one direction at the same time, but can not move toward both directions.
MDI	It is the Medium Dependent Interface, in which, one Ethernet port is taken as the receiving terminal to connect to the port of other equipment.
MDI-X	Medium Dependent Interface Cross-over

Publisher: Beijing KYLAND Telecom Technology CO., LTD
Address: 5/F, Office Building, Transport Center, East of
Xisanqi Bridge Haidian District, Beijing, China
Website: <http://www.kyland.cn>
Postcode: 100096
Tel: (+86 10) 82900770
Fax: (+86 10) 82900780
Email : sales@kyland.cn