

SICOM3170

7+3G Port Gigabit
Managed Industrial
Ethernet Switch

CE, FCC, RoHS



- Bandwidth setting function enables port bandwidth configuration
- Enhanced Broadcast Storm Control
- EMC industrial level 4, able to work in harsh environments such as strong electromagnetic interference
- Easy installation (slide it into the chassis and it immediately powers up)
- Plug and play, no power supply or electrical connections to worry about, 12VDC or 24VDC power supply is offered by the cabinet backplane
- Compatible with the interface requirements in the Caltrans TEES (170/332) specification
- Operating temperature: -40 to 85°C (-40 to 185°F)
- Aluminum case with fanless design (Convection Cooled)
- IP40 protection class

Overview

SICOM3170 is an ultra low power consumption (less than 8 Watts), Managed Industrial Ethernet switch. This dual slot Ethernet switch is designed to slide into an open Detector Chassis Slot of any Signal cabinet. This Managed Industrial Ethernet Switch is widely deployed in SCADA and OSS networks around world. This proven ultra low power consumption switch (Green Product - RoHS) features 2 SFP Gigabit ports, Seven 10/100 RJ45 Ports and One 10/100/1000 RJ45 Port. The SICOM3170 Industrial Signal Control switch is the first of a series of EZ Traffic Networks products from Kyland and a continuation of our "Green Ethernet" product line.

The "SICOM 3170" Industrial Ethernet switch offers a significant increase in the application and bandwidth capabilities of the highly configurable Kyland SICOM line of Managed Industrial Ethernet switches. This is the perfect switch for the deployment of bandwidth-intensive applications such as internal and external video surveillance at traffic intersections, local and regional control systems. This network switch can be easily installed into any traffic cabinet with an open dual slot in a detector input chassis. Clean, filtered 12VDC or 24VDC power is provided directly from the back-plane of the detector chassis and eliminates adding to the mess of additional power supplies and power cables within the traffic cabinet. The SICOM 3170 is the easiest and fastest to deploy Industrial Ethernet network switch. Requiring less than 8 Watts of power to operate it is also a "Green Ethernet" Industrial Ethernet switch, and fully RoHS compliant.

Features

- 2 Gigabit SFP fiber Uplink ports, 1 RJ45 10/100/1000Base-TX port, 7 RJ45 10/100Base-TX ports
- Supports DT-Ring and DT-Ring+ (Self Healing Rings with a Recovery time of less than 50ms) and Rapid Spanning Tree-RSTP/STP (IEEE802.1w/d)
- Supports Ring, Link, Star and Tangent Ring network topologies
- Ultra low power consumption, the SICOM3170 uses less than 8 Watts of power under fully loaded conditions
- Supports IGMP Snooping, Port Mirroring, QoS, VLAN and link aggregation
- Supports CLI, TELNET, WEB, SNMP v1/v2/v3 and OPC management control
- Supports TACACS+, Radius, SSH/SSL with improved Network Security functions
- Supports Automatic Network Topology Discovery and Generation with Kyvision3.0 centralized management
- SICOM series uniform Kyvision3.0 management software
- Secure MAC and port binding function, supports static FDB

Technical Specifications

Standard

- IEEE802.3
 - IEEE802.3u
 - IEEE802.3x
 - IEEE802.3z
 - IEEE802.3ab
 - IEEE802.1q
 - IEEE802.1p
 - IEEE802.1d
 - IEEE802.1w
- Store and forward switching mode

Network

Ring, chain, star and tangent ring network topology

Interface

Gigabit SFP port: 2 Gigabit SFP ports, 1000Base-SX/LX/LH/ZX modules with LC connector can be selectable
1000M port: 1 10/100/1000Base-TX RJ45 port
100M port: 7 10/100Base-TX RJ45 ports
CONSOLE port: RS232, RJ45

LED

Power status LED: PWR (Lightening: power on; Off: no power or device failure)
Running LED: Run (Blinking: system running well; Off: system failure of not booted)
SFP port LED: Link/Act (Lightening: port linked; Blinking: port with data transmitting; Off: no active network connection)
1000M port LED: Green light/Link (Lightening: port linked; Off: no active network connection). Yellow light/Act (Lightening: port with data transmitting; Off: port without data transmitting)
100M port LED: Yellow light/Speed (Lightening: 100M; Off: 10M). Green light/Link/Act (Lightening: port linked; Blinking: data transmitting; Off: no active network connection)

Performance

Backplane switching capacity: 9.6G
MAC Address Table Size: 8K

Cable

Twisted pair: 0-100m (Standard CAT5, CAT5e, CAT6, CAT6a network cable)
Multi-mode fiber: 1310nm, 0-2km (1000M)
Single-mode fiber: 1310nm, 0-40km; 1550nm, 0-80km

Power Requirements

Power input: Universal power supply 9-36VDC (12VDC, 24VDC)
Power consumption: <8W

Physical Characteristics

Casing: IP40 protection
Aluminum housing fanless design
Dimensions (WxHxD): 58x114x205mm (2.28x4.49x8.07 in.)
(Including the handle)
Weight: 0.8kg (1.764 pound)
Installation: Rail installation in Caltrans TEES (170/332) cabinet

Environmental Limits

Operating Temperature: -40 to 85°C (-40 to 185°F)
Storage Temperature: -40 to 85°C (-40 to 185°F)
Ambient Relative Humidity: 0 to 95% (non-condensing)

Approvals

IEC61000-4-2 (ESD): ±8KV contact discharge, ±15KV air discharge
IEC61000-4-3 (RS): 10V/M (80-1000MHz)
IEC61000-4-4 (EFT): ±4KV power line, ±2KV data line

IEC61000-4-5 (Surge): power line ±4KV CM/ ±2KV DM, data line ±2KV
IEC61000-4-6 (CS): 3V (10KHZ-150KHZ), 10V (150KHZ-80MHz)
IEC61000-4-8 (Power frequency magnetic field): 100A/m cont. 1000A/m, 1s to 3s
IEC61000-4-12/18 (Damped oscillatory wave): 2.5KV CM, 1KV DM
IEC61000-4-10 (Damped oscillatory): 30A/m
IEC61000-4-16 (Common mode conduct): 30V cont. 300V, 1s
FCC CFR47 Part 15/EN55022: Class A&B
IEC61000-6-2 (Industrial Standards), IEC61850-3 (Substations), IEEE1613 (Electric Power Substations), EN50121-4 (Railway Applications)

CE, FCC, ROHS

MTBF

35 years

Warranty

5 years

Ordering Information

Model	Description
SICOM3170-2GX-GE-7T	Managed traffic Ethernet switch with 2 Gigabit SFP slots, 1 10/100/1000Base-T(X) ports, RJ45 connector and 7 10/100Base-T(X) ports, RJ45 connector, 9-36VDC, -40 to 85°C operating temperature

Power supply: 9-36VDC (12VDC, 24VDC)

Optional Gigabit SFP Modules

Model	Description
SM-GSFP-LX/LC-550	SFP module, 1 x 1000M Multi Mode, LC Connector, 1310nm, 550m
SM-GSFP-LX/LC-10	SFP module, 1 x 1000M Single Mode, LC Connector, 1310nm, 10km
SM-GSFP-LH/LC-40	SFP module, 1 x 1000M Single Mode, LC Connector, 1310nm, 40km
SM-GSFP-ZX/LC-60	SFP module, 1 x 1000M Single Mode, LC Connector, 1550nm, 60km
SM-GSFP-ZX/LC-80	SFP module, 1 x 1000M Single Mode, LC Connector, 1550nm, 80km

Mechanical Drawing

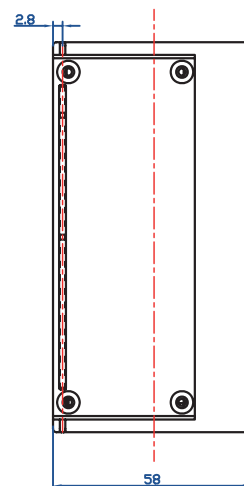
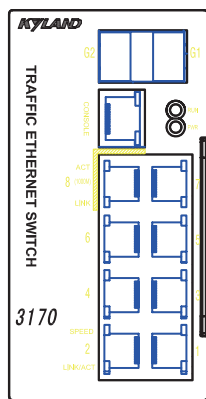
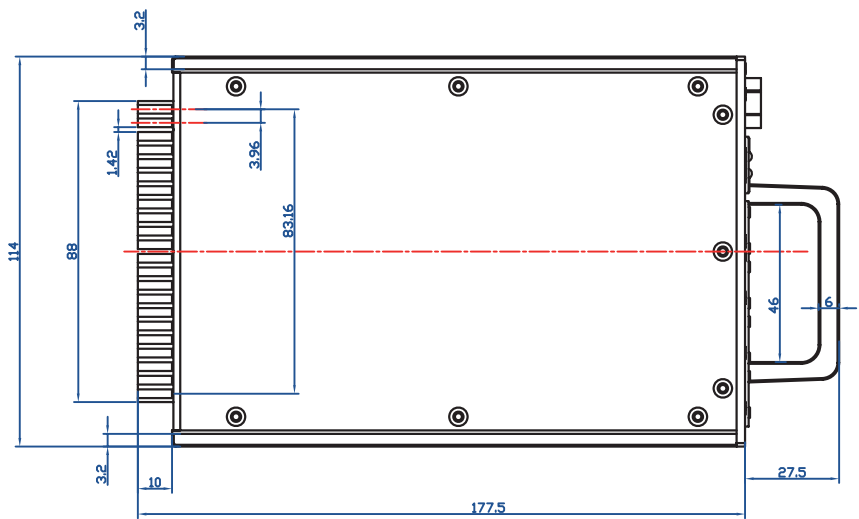
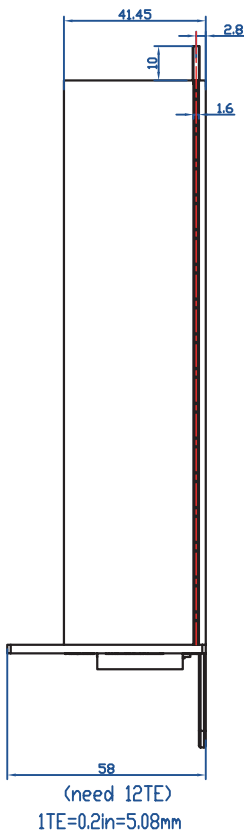
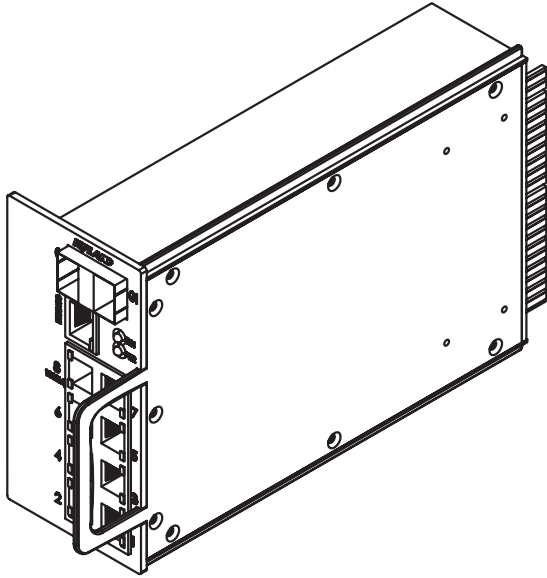

Please visit our website: www.kyland.cn for the latest updates.