

2-axis Motion Control Module User Manual

(I-8092F)

(Version 2.3)

Macro Function Library in C++ for
WinCon and I-8000 series PAC controllers



ICP DAS CO., LTD.

泓格科技股份有限公司

Warranty

All products manufactured by ICPDAS Inc. are warranted against defective materials for a period of one year from the date of delivery to the original purchaser.

Warning

ICPDAS Inc. assumes no liability for damages consequent to the use of this product. ICPDAS Inc. reserves the right to change this manual at any time without notice. The information furnished by ICPDAS Inc. is believed to be accurate and reliable. However, no responsibility is assumed by ICPDAS Inc. for its use, or for any infringements of patents or other rights of third parties resulting from its use.

Copyright

Copyright 1997-2005 by ICPDAS Inc., LTD. All rights reserved worldwide.

Trademark

The names used for identification only maybe registered trademarks of their respective companies.

License

The user can use, modify and backup this software on a single machine. The user may not reproduce, transfer or distribute this software, or any copy, in whole or in part.

INDEX

1 PREFACE	7
1.1 Introduction.....	7
1.2 Basic and Macro functions.....	7
1.3 Function description	8
2 BASIC SETTINGS.....	9
2.1 Code numbers for axes	9
2.2 Registration of Modules and getting the LIB version	9
2.3 Resetting Module	12
2.4 Pulse Output Mode Setting	12
2.5 Setting the Maximum Speed	13
2.6 Setting the Active Level of the Hardware Limit Switches	14
2.7 Setting the Motion Stop Method When Limit Switch Is Sensed	15
2.8 Setting the Trigger Level of the NHOME Sensor	15
2.9 Setting Trigger Level of the Home sensor	16
2.10 Setting and Clearing the Software Limits	16
2.11 Setting the Encoder Related Parameters	17
2.12 Setting the Servo Driver (ON/OFF)	18
2.13 Setting the SERVO ALARM Function	19
2.14 Setting the Active Level of the In-Position Signals	20
2.15 Setting the Time Constant of the Digital Filter	20
2.16 Position Counter Variable Ring.....	22
2.17 Triangle prevention of fixed pulse driving	23
2.18 External Pulse Input.....	24
2.18.1 Handwheel (Manual Pulsar) Driving	24
2.18.2 Fixed Pulse Driving Mode	25
2.18.3 Continuous Pulse Driving Mode.....	26
2.18.4 Disabling the External Signal Input Functions.....	27
2.19 Configure hardware with pre-defined configuration file.....	28
3 READING AND SETTING THE REGISTERS.....	29
3.1 Setting and Reading the Command Position (LP).....	29
3.2 Setting and Reading the Encoder Counter.....	30
3.3 Reading the Current Velocity	31
3.4 Reading the Current Acceleration.....	31
3.5 Reading the DI Status	32
3.6 Reading and Clearing the ERROR Status	34
3.7 Setting the general Digital output	35

4 FRNET FUNCTIONS (FOR I8092F ONLY).....	36
4.1 Read FRnet DI Signals	36
4.2 Write data to FRnet DO	37
5 AUTO HOMING	38
5.1 Setting the Homing Speed	38
5.2 Using an Limit Switch as the HOME sensor.....	39
5.3 Setting the Homing Mode.....	39
5.4 Starting the Homing Sequence	41
5.5 Waiting for the Homing sequence to be Completed	41
6 GENERAL MOTION CONTROL	42
6.1 Independent Axis Motion Control.....	42
6.1.1 Setting the Acceleration/Deceleration Mode	42
6.1.2 Setting the Start Speed.....	44
6.1.3 Setting the Desired Speed.....	44
6.1.4 Setting the Acceleration	45
6.1.5 Setting the Deceleration	45
6.1.6 Setting the Acceleration Rate	47
6.1.7 Setting the Value of the Remaining Offset Pulses	48
6.1.8 Fixed Pulse Output	49
6.1.9 Continuous Pulse Output.....	50
6.2 Interpolation Commands	51
6.2.1 Setting the Speed and Acc/Dec Mode for Interpolation	51
6.2.2 Setting the Vector Starting Speed	55
6.2.3 Setting the Vector Speed.....	55
6.2.4 Setting the Vector Acceleration	56
6.2.5 Setting the Vector Deceleration Value.....	57
6.2.6 Setting the Vector Acceleration Rate	58
6.2.7 Setting the Number of the Remaining Offset Pulses	59
6.2.8 2-Axis Linear Interpolation Motion	60
6.2.9 2-Axis Circular Interpolation Motion (an Arc).....	61
6.2.10 2-Axis Circular Interpolation Motion	63
6.3 Continuous Interpolation	65
6.3.1 2-Axis Rectangular Motion.....	65
6.3.2 2-Axis Continuous Linear Interpolation.....	66
6.3.3 Multi-Segment Continuous Interpolation (Using Array)	68
6.3.4 2-Axis Ratio Motion.....	69
6.3.5 Mixed Linear and Circular 2-axis motions in Continuous Interpolation	71
6.4 Set the Interrupt Factors.....	74
6.4.1 Set the Interrupt Factors	74
6.4.2 Interrupt Disabled	76
6.4.3 Read the Interrupt Occurrence	77
6.5 Other functions.....	78

6.5.1 Holding the Driving Command	78
6.5.2 Release the Holding Status, and Start the Driving.....	78
6.5.3 Waiting until the Motion Is Completed	79
6.5.4 Stopping the Axes	81
6.5.5 Clear the Stop Status	85
6.5.6 End of Interpolation	85
6.5.7 Setting the COMPARE value	86
APPENDIX A (I-8092F BASIC FUNCTIONS)	87
A.1 i8092F Command Set.....	87
A.2 Pulse Output Command.....	88
A.2.1 Signal Types.....	88
A.2.2 Fixed Pulse Driving	90
A.2.3 Changing Output Pulse Numbers in Driving	90
A.2.4 Offset Setting for Acceleration/Deceleration Driving.....	90
A.2.5 Continuous Drive Pulse Output	92
A.2.6 Constant Speed Driving	93
A.3 Profile Acceleration/Deceleration Planning.....	94
A.3.1 Trapezoidal Driving [Symmetric].....	94
A.3.2 Trapezoidal Driving [Asymmetric]	96
A.3.3 Triangle Prevention	98
A.3.4 S-curve Acceleration / Deceleration [Symmetry].....	99
A.4 Pulse Output Commands	103
A.4.1 2-Axes Interpolation	103
A.4.2 Circular Interpolation	104
A.4.3 Bit Pattern Interpolation.....	107
A.4.4 Continuous Interpolation.....	109
A.5 Automatic Home Search.....	111
A.6 Interrupt Control	112
A.6.1 Interrupt for Independent axis.....	112
A.6.2 Interrupt for Interpolation	112
A.7 I-8092F Function Library	113
A.7.1 Register management functions.....	114
A.7.2 Functions for Initial Setting	121
A.7.3 Motion Status Management Functions.....	127
A.7.4 Basic Motion Command Functions	134
A.7.5 Interpolation Functions.....	145
A.7.6 Automatic Home Search	158
A.7.7 Interrupt Function.....	170
A.7.8 FRnet Related Functions	177
A.8 i8092 Command Lists	179
A.8.1 Data Setting Commands	179
A.8.2 Data Reading Commands	179
A.8.3 Driving Commands.....	180
A.8.4 Interpolation Commands	180
A.8.5 Other commands	180

APPENDIX B: MCX312 REGISTERS.....	181
B.1 Command Register: WR0	181
B.2 Mode Register1: WR1.....	182
B.3 Mode Register2: WR2.....	184
B.4 Mode Register3: WR3.....	186
B.5 Output Register: WR4.....	189
B.7 Data Register: WR6/WR7	190
B.8 Main Status Register: RR0.....	190
B.9 Status Register 1: RR1	191
B.10 Status Register 2: RR2	193
B.11 Status Register 3: RR3	194
B.12 Input Register: RR4 / RR5	195
B.13 Data-Read Register: RR6 / RR7	195

1 Preface

1.1 Introduction

- This manual provides complete and detailed description of i8092F functions for users to develop programs for their control of automatic equipments. Many examples are included in this manual for reference to write efficient application programs.
- This manual includes six chapters and two appendices. This chapter gives a brief description of this manual. Chapter 2 to 6 is the explanations of macro functions (MF). Appendices A and B are the descriptions of basic functions (BF) and the registers of MCX312, respectively.
- The functions defined in DLL file are explained here. This DLL can be used on different developing software platforms, such as eVC++, VB.net, and C#.net, and different OS systems (MiniOS7 / WinCE).

1.2 Basic and Macro functions

- Basic functions are suitable for those who are familiar with the MCX312 motion chip. These functions can directly read/write the registers of motion chip. However, users need to know more details about this motion chip.
- Macro functions provide a set of much easy-to-use functions that simplify the programming for users. Some necessary settings, such as speed range and deceleration point, are calculated inside those functions to ease the loading of users on having to understand the motion chip. Some useful costumed functions are provided for users to develop applications efficiently.
- **If possible, do not mix these two groups of functions together. Some internal parameters may be changed beyond users' consideration.**

1.3 Function description

All functions are listed in following form:

- **Function_name** (parameter1, parameter2, ...)

Description: Explanation of this function.

Parameters: Definitions of the parameters and how to use them.

Return: The return value of this function.

Example: Simple example program in C++.

Remark: Comments.

2 Basic Settings

2.1 Code numbers for axes

The axis assignments follow the definitions listed below: X=1, Y=2. If X and Y axes are assigned simultaneously, then the code number is 3. An assignment for either single axis or multiple axes at the same time is possible. Available axis code numbers are listed below. The type of the axis argument used in the functions is defined as WORD.

Table 2-1 Axis assignments and their corresponding codes

Axis	X	Y	XY
Code	0x1	0x2	0x3
Name	AXIS_X	AXIS_Y	AXIS_XY

2.2 Registration of Modules and getting the LIB version

- **BYTE** i8092MF_REGISTRATION(**BYTE** *cardNo*, **BYTE** *slot*)

Description:

This function registers a module that is installed in slot number, *slot*, by assigning a card number. Registration must be performed for each I-8092F motion control module before other functions are called. After registration, each module can be identified by its corresponding module number.

Parameters:

cardNo: Module number
slot: Slot number
 for I-8000: 0~7
 for WinCon-8000: 1~7

Return:

YES Normal
NO Abnormal

Example:

```
//===== for WinCon-8000 =====
```

```

//set each module number the same as the slot number, respectively.
//(slot1 ~ slot7)
BYTE cardNo;
BYTE slot;
int Found = 0;
for (slot = 1; slot < 8; slot++)
{
    cardNo = slot;
    if (i8092MF_REGISTRATION(cardNo, slot) == YES)
    { //slot number begins from 1.
        //if a module is found, then it is registered as its slot number.
        i8092MF_RESET_CARD(cardNo);
        Found++;
    }
}
if (Found == 0)
{
    //if Wincon cannot find any I-8092F module,
    //please add codes to handle the exception here.
    return;
}
//===== for I-8000 =====
//set the module number the same as the slot number, respectively.
//(slot1 ~ slot7)
BYTE cardNo;
BYTE slot;
int Found = 0;
for (slot = 0; slot < 8; slot++)
{
    cardNo = slot + 1;
    //slot number begins from 0, but module number begin from 1.

    if (i8092MF_REGISTRATION(cardNo, slot) == YES)
    {
        //if a module is found, then it is registered by giving a number.
        i8092MF_RESET_CARD(cardNo);
        Found++;
    }
}
if (Found == 0)
{
    //if Wincon cannot find any I-8092F module,
    //please add codes to handle the exception here.
    return;
}

```

- **WORD** i8092MF_GET_VERSION(void)

Description:

Read the version of current i8092 library.

Parameters:

cardNo: Module number

Return:

Version code:

including information of the year and the month: 0x0000 ~ 0x9999

Example:

```
WORD VER_No;  
VER_No = i8092MF_GET_VERSION();  
//Read the version code of i8092.dll
```

Remark:

If the return value is **0x0607**

06 : the year is 2006

07: the month is July.

2.3 Resetting Module

- **void** `i8092MF_RESET_CARD(BYTE cardNo)`

Description:

This function resets module using a software command.

Parameters:

cardNo: Module number

Return:

None

Example:

```
i8092MF_RESET_CARD(1);  
//Reset module 1.
```

2.4 Pulse Output Mode Setting

- **void** `i8092MF_SET_PULSE_MODE(BYTE cardNo, WORD axis, BYTE nMode)`

Description:

This function sets the pulse output mode as either CW/CCW or PULSE/DIR for the assigned axes and their direction definition.

Parameters:

cardNo: Module number
axis: Axis or axes (Please refer to Table 2-1)
nMode: Assigned mode (Please refer to Table 2-2)

Return:

None

Example:

```
i8092_SET_PULSE_MODE(1, AXIS_XYZ, 2);  
//set the pulse mode of X, Y, and Z axes as mode 2  
i8092_SET_PULSE_MODE(1, AXIS_U, 3);  
//set the pulse mode of U axis as mode 3
```

Table 2-2 A List of pulse output modes

	mode	Pulse output signals	
		nPP	nPM
CW / CCW	0	CW (rising edge)	CCW (rising edge)
	1	CW (falling edge)	CCW (falling edge)
PULSE / DIR	2	PULSE (rising edge)	DIR (LOW:+dir/ HIGH:-dir)
	3	PULSE (falling edge)	DIR (LOW:+dir/ HIGH:-dir)
	4	PULSE (rising edge)	DIR (HIGH:+dir/ LOW:-dir)
	5	PULSE (falling edge)	DIR (HIGH:+dir/ LOW:-dir)

2.5 Setting the Maximum Speed

- `void i8092MF_SET_MAX_V(BYTE cardNo, WORD axis, DWORD data)`

Description:

This function sets the maximum rate for the output pulses (speed). A larger value will cause a rougher resolution. For example, when the maximum speed is set as 8000 PPS, the resolution is 1 PPS; when the maximum speed is set as 16000 PPS, the resolution is 2 PPS; when maximum speed is set as 80000 PPS, the resolution is 10 PPS, etc. The maximum value is 4,000,000 PPS, which means the resolution of speed will be 500 PPS. This function change the resolution of speed to reach the desired maximum speed. Since the scale in hardware is changed, other parameters will be influenced too, such as the starting speed, the acceleration, and the jerk. It is recommended to set the maximum speed value as a integral multiplier of 8000.

Parameters:

cardNo: Module number
axis: Axis or axes (Please refer to Table 2-1)
data: The assigned maximum speed of each axis when the controller performs an interpolation motion. However, setting the value of axis 1 is enough. For axis 1, the maximum value is 4,000,000 PPS.

Return:

None

Example:

```
i8092MF_SET_MAX_V(1, AXIS_XY, 200000L);  
//The maximum speed for the X and Y axes of module 1 is 200KPPS.  
//The resolution of the speed will be 200000/8000 = 25 PPS.
```

2.6 Setting the Active Level of the Hardware Limit Switches

- **void** i8092MF_SET_HLMT(**BYTE** *cardNo*, **WORD** *axis*, **BYTE** *nFLEdge*, **BYTE** *nRLEdge*)

Description:

This function sets the active logic level of the hardware limit switch inputs.

Parameters:

cardNo: Module number
axis: Axis or axes (Please refer to Table 2-1)
nFLEdge: Active level setting for the forward limit switch.
0 = low active; 1 = high active
nRLEdge: Active level setting for the reverse limit switch.
0 = low active; 1 = high active

Return:

None

Example:

```
i8092MF_SET_HLMT(1, AXIS_XY, 0, 0);  
//set all the trigger levels as low-active for all limit switches  
//on module 1.
```

2.7 Setting the Motion Stop Method When Limit Switch Is Sensed

- `void i8092MF_LIMITSTOP_MODE (BYTE cardNo, WORD axis, BYTE nMode)`

Description:

This function sets the motion stop mode of the axes when the corresponding limit switches are detected.

Parameters:

cardNo: Module number
axis: Axis or axes (Please refer to Table 2-1)
nMode: 0: stop immediately; 1: decelerating to stop

Return:

None

Example:

```
i8092MF_LIMITSTOP_MODE(1, AXIS_X, 0);  
//set X axis to stop immediately if any limit switch on X axis is triggered.
```

2.8 Setting the Trigger Level of the NHOME Sensor

- `void i8092MF_SET_NHOME(BYTE cardNo, WORD axis, BYTE nNHEdge)`

Description:

This function sets the trigger level of the near home sensor (NHOME).

Parameters:

cardNo: Module number
axis: Axis or axes (Please refer to Table 2-1)
nNHEdge: Active level setting for the near home sensor.
0 = low active; 1 = high active

Return:

None

Example:

```
i8092MF_SET_NHOME(1, AXIS_XY, 0);  
//set the trigger level of NHOME of X and Y axes on module 1 to be active low.
```

2.9 Setting Trigger Level of the Home sensor

- `void i8092MF_SET_HOME_EDGE(BYTE cardNo, WORD axis, BYTE nHEdge)`

Description:

This function sets the trigger level of the home sensor (HOME).

Parameters:

cardNo: Module number
axis: Axis or axes (Please refer to Table 2-1)
nHEdge: Active level setting for the home sensor.
0 = low active; 1 = high active

Return:

None

Example:

```
i8092MF_SET_HOME_EDGE(1, AXIS_XY, 1);  
//set the trigger level as high active for all home sensors on module 1.
```

2.10 Setting and Clearing the Software Limits

- `void i8092MF_SET_SLMT(BYTE cardNo, WORD axis, long dwFL, long dwRL, BYTE nType)`

Description:

This function sets the software limits.

Parameters:

cardNo: Module number
axis: Axis or axes (Please refer to Table 2-1)
dwFL: Value of the forward software limit
(-2,147,483,648 ~ +2,147,483,647)
dwRL: Value of the reverse software limit
(-2,147,483,648 ~ +2,147,483,647)
nType: Position counter to be compared:
0 = logical position counter (LP), i.e., the command position
1 = encoder position counter (EP), i.e., the real position

Return:

None

Example:

```
i8092MF_SET_SLMT(1, AXIS_XY, 20000, -3000, 0);  
//set the forward software limit as 20000 and the reverse  
//software limit as -3000 for all axes on module 1.
```

- **void i8092MF_CLEAR_SLMT**(**BYTE** *cardNo*, **WORD** *axis*)

Description:

This function clears the software limits.

Parameters:

cardNo: Module number
axis: Axis or axes (Please refer to Table 2-1)

Return:

None

Example:

```
i8092MF_CLEAR_SLMT(1, AXIS_XY);  
//clear the software limits for all axes on module 1.
```

2.11 Setting the Encoder Related Parameters

- **void i8092MF_SET_ENCODER**(**BYTE** *cardNo*, **WORD** *axis*, **BYTE** *nMode*,
BYTE *nDivision*, **BYTE** *nZEdge*)

Description:

This function sets the encoder input related parameters.

Parameters:

cardNo: Module number
axis: Axis or axes (Please refer to Table 2-1)
nMode: Encoder input type: 0 = A quad B; 1 = up/down
nDivision: Division setting for A quad B input signals:
0 = 1/1
1 = 1/2
2 = 1/4
nZEdge: Sets the trigger level for the Z phase
0 = low active; 1 = high active

Return:
None

Example:
`i8092MF_SET_ENCODER(1, AXIS_XY, 0, 0, 0);`
`//set the encoder input type as A quad B; the division is 1;`
`//and the Z phase is low active.`

- `void i8092MF_SET_EN_DIR(BYTE cardNo, WORD axis, BYTE nDir)`

Description:
This function sets the encoder input direction.

Parameters:
`cardNo:` Module number
`axis:` Axis or axes (Please refer to Table 2-1)
`nDir:` Encoder input direction: 0=positive dir; 1= negative dir

Return:
None

Example:
`i8092MF_SET_EN_DIR(1, AXIS_XY, 0);`
`//set the encoder input direction to positive direction;`

2.12 Setting the Servo Driver (ON/OFF)

- `void i8092_SERVO_ON(BYTE cardNo, WORD axis)`

Description:
This function outputs a DO signal (ENABLE) to enable the motor driver.

Parameters:
`cardNo:` Module number
`axis:` Axis or axes (Please refer to Table 2-1)

Return:
None

Example:
`i8092_SERVO_ON(1, AXIS_XY);`
`//enables all drivers on module 1.`

- `void i8092_SERVO_OFF(BYTE cardNo, WORD axis)`

Description:

This function outputs a DO signal (ENABLE) to disable the motor driver.

Parameters:

cardNo: Module number
axis: Axis or axes (Please refer to Table 2-1)

Return:

None

Example:

```
i8092_SERVO_OFF(1, AXIS_XY);
//disables all drivers on module 1.
```

2.13 Setting the SERVO ALARM Function

- `void i8092MF_SET_ALARM(BYTE cardNo, WORD axis, BYTE nMode, BYTE nAEdge)`

Description:

This function sets the ALARM input signal related parameters.

Parameters:

cardNo: Module number
axis: Axis or axes (Please refer to Table 2-1)
nMode: Mode: 0 = disable ALARM function;
 1 = enable ALARM function
nAEdge: Sets the trigger level
 0 = low active; 1 = high active

Return:

None

Example:

```
i8092MF_SET_ALARM(1, AXIS_XY, 1, 0);
//enable the ALARM for X and Y axes on module 1 and set them
//as low-active.
```

2.14 Setting the Active Level of the In-Position Signals

- `void i8092MF_SET_INPOS(BYTE cardNo, WORD axis, BYTE nMode, BYTE nEdge)`

Description:

This function sets the INPOS input signal related parameters.

Note: Sometimes, this signal is used to connect the SERVO READY input signal. Users should take care of what signal the daughter board is wired.

Parameters:

cardNo: Module number
axis: Axis or axes (Please refer to Table 2-1)
nMode: Mode: 0 = disable INPOS input;
1 = enable INPOS input
nEdge: Set the trigger level
0 = low active; 1 = high active

Return:

None

Example:

```
i8092MF_SET_INPOS(1, AXIS_X, 1, 0);  
//enable the INPOS function of the X axis on module 1 and set it to be low-active.
```

Note: Please refer to the example shown in Fig. 2.12 for wiring of the general DI input.

2.15 Setting the Time Constant of the Digital Filter

- `void i8092MF_SET_FILTER(BYTE cardNo, WORD axis, WORD FEn, WORD FLn)`

Description:

This function selects the axes and sets the time constant for digital filters of the input signals.

Parameters:

cardNo: Module number
axis: Axis or axes (Please refer to Table 2-1)
FEn: Enabled filters. The sum of the code numbers (0~31) are used to select input signals. Please refer to the following table.

Code number	Enabling filters
1	EMG, nLMTP, nLMTM, nIN0, nIN1
2	nIN2
4	nINPOS, nALARM
8	nEXPP, nEXPM, EXPLSN
16	nIN3

FLn: Sets the filter time constant (0~7) as follows.

Code	Removable max. noise width	Input signal delay time
0	1.75 μ SEC	2 μ SEC
1	224 μ SEC	256 μ SEC
2	448 μ SEC	512 μ SEC
3	896 μ SEC	1.024mSEC
4	1.792mSEC	2.048mSEC
5	3.584mSEC	4.096mSEC
6	7.168mSEC	8.192mSEC
7	14.336mSEC	16.384mSEC

Return:

None

Example:

```
i8092MF_SET_FILTER(1, AXIS_XY, 21, 3);
//set the filter time constants of X and Y axes as 1.024mSEC.
//These filters include EMG, nLMTP, nLMTM, nIN0, nIN1, nINPOS, nALARM,
//and nIN3.
//(21 = 1+4+16)   1: EMG + nLMP + nLMPM + nIN0 + nIN1;
//                4: nINPOS + nALARM;
//                16: nIN3.
```

Note: The default wiring design is: nIN0 is connected to the NEAR HOME (NHOME) sensors; nIN1 is connected to the HOME sensors; and nIN2 is connected to the index of Encoder input (Z phase).

2.16 Position Counter Variable Ring

- `void i8092MF_VRING_ENABLE(BYTE cardNo, WORD axis, DWORD nVRing)`

Description:

This function enables the linear counter of the assigned axes as variable ring counters.

Parameters:

cardNo: Module number
axis: Axis or axes (Please refer to Table 2-1)
nVRing: Maximum value of the ring counter
(-2,147,483,648 ~ +2,147,483,647)

Return:

None

Example:

```
i8092MF_VRING_ENABLE(1, AXIS_X, 9999);  
//set the X axis of module 1 to be a ring counter. The encoder  
//values will be 0 to 9999.
```

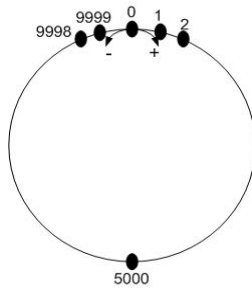

The encoder value is 0 to 9999. When the counter value reach 9999, an adding pulse will cause the counter to reset to 0. When the counter value is 0, a lessening pulse will let the counter set to 9999.

Max. ring encoder value = 9999

- Note:**
1. This function will set the LP and EP simultaneously.
 2. If this function is enabled, the software limit function cannot be used.

- `void i8092MF_VRING_DISABLE(BYTE cardNo, WORD axis)`

Description:

This function disables the variable ring counter function.

Parameters:

cardNo: Module number
axis: Axis or axes (Please refer to Table 2-1)

Return:

None

Example:

```
i8092MF_VRING_DISABLE(1, AXIS_X);  
//disable the ring counter function for the X axis  
//on module 1.
```

2.17 Triangle prevention of fixed pulse driving

- **void** i8092MF_AVTRI_ENABLE (**BYTE** *cardNo*, **WORD** *axis*)

Description:

This function prevents a triangle form in linear acceleration (T-curve) fixed pulse driving even if the number of output pulses is low.

Parameters:

cardNo: Module number
axis: Axis or axes (Please refer to Table 2-1)

Return:

None

Example:

```
i8092MF_AVTRI_ENABLE(1, AXIS_X);  
//set the X axis of module 1 not to generate a triangle form in its speed profile.
```

- **void** i8092MF_AVTRI_DISABLE (**BYTE** *cardNo*, **WORD** *axis*)

Description:

This function disable the function that prevents a triangle form in linear acceleration fixed pulse driving.

Parameters:

cardNo: Module number
axis: Axis or axes (Please refer to Table 2-1)

Return:

None

Example:

```
i8092MF_AVTRI_DISABLE(1, AXIS_X);  
//enable the X axis of module 1 to generate a triangle form in its  
//speed profile if the pulse number for output is too low.
```

2.18 External Pulse Input

2.18.1 Handwheel (Manual Pulsar) Driving

- `void i8092MF_EXD_MP(BYTE cardNo, WORD axis, long data)`

Description:

This function outputs pulses according to the input pulses from a handwheel.

Parameters:

cardNo: Module number
axis: Axis or axes (Please refer to Table 2-1.)
The axis can be either X and Y
data: Gain (a multiplier)

Return:

None

Example:

```
i8092MF_EXD_MP(1, AXIS_X, 1);  
//Each time the handwheel inputs a pulse to the X axis  
//on module 1, the controller will output 1 pulses to the motor driver.
```

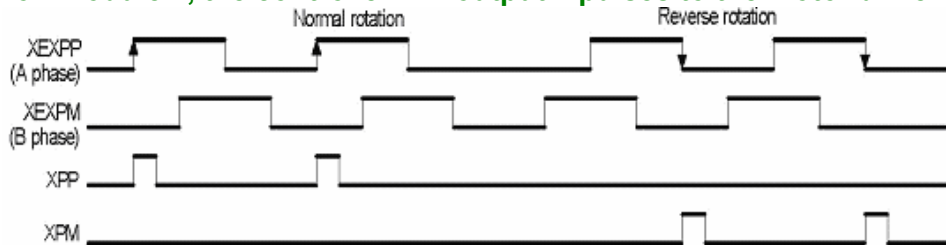

Example of gain = 1

```
i8092MF_EXD_MP(1, AXIS_X, 2);  
//Each time the handwheel inputs a pulse to the X axis  
//on module 1, the controller will output 2 pulses to the motor driver.
```

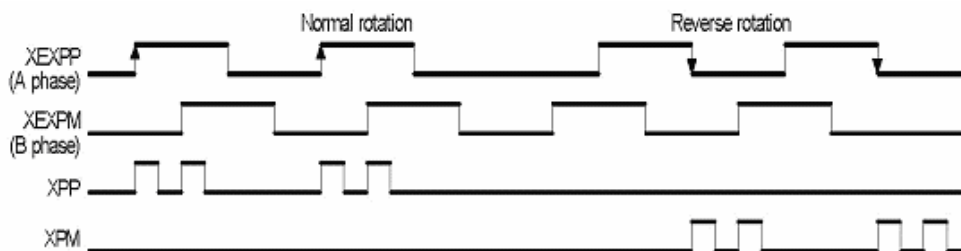

Example of gain = 2

2.18.2 Fixed Pulse Driving Mode

- `void i8092MF_EXD_FP(BYTE cardNo, WORD axis, long data)`

Description:

This function outputs fixed pulses according to the trigger input (the falling edge of the nEXP+ signal) from a handwheel.

Parameters:

cardNo: Module number
axis: Axis or axes (Please refer to Table 2-1.)
The axis can be either X and Y
data: Number of fixed pulses.

Return:

None

Example:

```
i8092MF_EXD_FP(1, AXIS_X, 5);  
//Each time the controller detects a falling edge of an XEXP+  
//signal, it will output 5 pulses to the X axis.
```

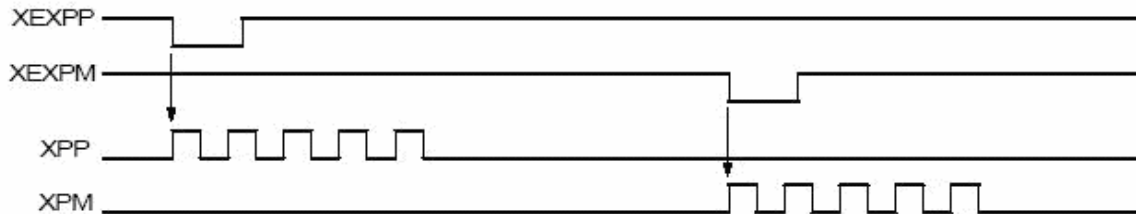

Example of fixed pulse driving using an external signal

2.18.3 Continuous Pulse Driving Mode

- `void i8092MF_EXD_CP(BYTE cardNo, WORD axis, long data)`

Description:

The controller will continuously output pulses in positive direction if the falling edge of nEXP+ signal from a handwheel is detected. Conversely, it will continuously output pulses in negative direction if the falling edge of nEXP- signal is detected.

Parameters:

cardNo: Module number
axis: Axis or axes (Please refer to Table 2-1.)
The axis can be either X and Y
data: Pulse output speed in PPS

Return:

None

Example:

```
i8092MF_EXD_CP(1, AXIS_X, 20);  
//Each time the controller detects a falling edge of an XEXP+  
//signal, it will continuously drive X axis at the speed of 20 PPS.
```

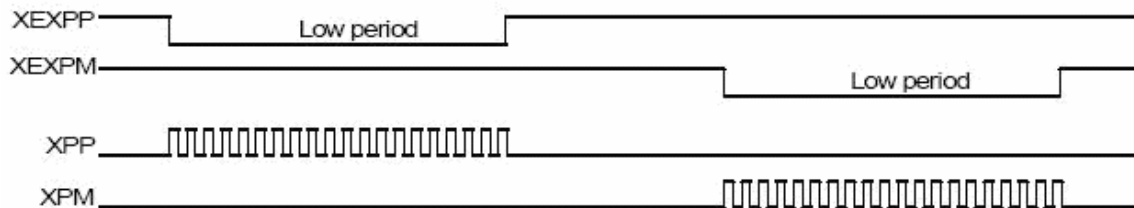

Continuous driving using an external signal

2.18.4 Disabling the External Signal Input Functions

- `void i8092MF_EXD_DISABLE(BYTE cardNo, WORD axis)`

Description:

This function turns off the external input driving control functions.

Parameters:

cardNo: Module number
axis: Axis or axes (Please refer to Table 2-1.)
The axis can be either X and Y

Return:

None

Example:

```
i8092MF_EXD_DISABLE(1, AXIS_X);  
//disable the external input driving control function  
//of X axis on module 1
```

2.19 Configure hardware with pre-defined configuration file

- **short** `i8092MF_LOAD_CONFIG` (**BYTE** *cardNo*)

Description:

This function loads the pre-defined configuration file and set the target I8092 module automatically. The configuration file is generated by the PACEzGo.

Parameters:

cardNo: Module number

Return:

0: successfully
-1: cannot open the pre-defined configuration file.

Example:

```
i8092MF_LOAD_CONFIG (1);  
//load the configuration file and configure the module 1.
```

3 Reading and Setting the Registers

3.1 Setting and Reading the Command Position (LP)

- `void i8092MF_SET_LP(BYTE cardNo, WORD axis, long wdata)`

Description:

This function sets the command position counter value (logical position counter, LP).

Parameters:

cardNo: Module number
axis: Axis or axes (Please refer to Table 2-1)
wdata: Position command
(-2,147,483,648 ~ +2,147,483,647)

Return:

None

Example:

```
i8092MF_SET_LP(1, AXIS_XY, 0);  
//Set the LP for the X, Y, Z, and U axes of module 1 as 0,  
//which means that all LP counters on module 1 will be cleared.
```

- `long i8092MF_GET_LP(BYTE cardNo, WORD axis)`

Description:

This function reads the command position counter value (logical position counter, LP).

Parameters:

cardNo: Module number
axis: Axis (Please refer to Table 2-1)
The axis can be either X and Y

Return:

The current LP value (-2,147,483,648 ~ +2,147,483,647)

Example:

```
long X_LP;  
X_LP = i8092MF_GET_LP(1, AXIS_X);  
//Reads the LP value of the X axis on module 1.
```

3.2 Setting and Reading the Encoder Counter

- **void** i8092MF_SET_EP(**BYTE** *cardNo*, **WORD** *axis*, **long** *wdata*)

Description:

This function sets the encoder position counter value (real position counter, or EP).

Parameters:

cardNo: Module number
axis: Axis or axes (Please refer to Table 2-1)
wdata: Position command
(-2,147,483,648 ~ +2,147,483,647)

Return:

None

Example:

```
i8092MF_SET_EP(1, AXIS_XY, 0);  
//Set the EP for the X, Y, Z, and U axes of module 1 as 0.  
//This command clears all EP counters on module 1.
```

- **long** i8092MF_GET_EP(**BYTE** *cardNo*, **WORD** *axis*)

Description:

This function reads the encoder position counter value (EP).

Parameters:

cardNo: Module number
axis: Axis (Please refer to Table 2-1)
The axis can be either X and Y

Return:

Current EP value (-2,147,483,648 ~ +2,147,483,647)

Example:

```
long X_EP;  
X_EP = i8092MF_GET_EP(1, AXIS_X);  
//reads the encoder value (EP) of the X axis on module 1.
```

3.3 Reading the Current Velocity

- **DWORD** `i8092MF_GET_CV`(**BYTE** *cardNo*, **WORD** *axis*)

Description:

This function reads the current velocity value.

Parameters:

cardNo: Module number
axis: Axis (Please refer to Table 2-1)
 The axis can be either X and Y

Return:

Current speed (in PPS)

Example:

```
DWORD dwdata;  
dwdata = i8092MF_GET_CV(1, AXIS_X);  
//reads the current velocity of the X axis on module 1.
```

3.4 Reading the Current Acceleration

- **DWORD** `i8092MF_GET_CA`(**BYTE** *cardNo*, **WORD** *axis*)

Description:

This function reads the current acceleration value.

Parameters:

cardNo: Module number
axis: Axis (Please refer to Table 2-1)
 The axis can be either X and Y

Return:

Current acceleration (in PPS/Sec)

Example:

```
DWORD dwdata;  
dwdata = i8092MF_GET_CA(1, AXIS_X);  
//reads the current acceleration value of the X axis on module 1.
```

3.5 Reading the DI Status

- **BYTE** `i8092MF_GET_DI`(**BYTE** *cardNo*, **WORD** *axis*, **WORD** *nType*)

Description:

This function reads the digital input (DI) status.

Parameters:

cardNo: Module number

axis: Axis (Please refer to Table 2-1)

The axis can be either X and Y

nType:

0 → DRIVING	(Check whether the axis is driving or not.)
1 → LIMIT+	(Check whether the limit+ is engaged or not.)
2 → LIMIT-	(Check whether the limit- is engaged or not.)
3 → EMERGENCY	(Check whether EMG signal is on or not.)
4 → ALARM	(Check the ALARM input signal.)
5 → HOME	(Check the HOME input signal)
6 → NHOME	(Check the Near HOME input signal)
7 → IN3	(Check the IN3 input signal)
8 → INPOS	(Check the INPOS input signal)
9 → INDEX	(Check the encoder Z-phase input signal)

Return:

YES on
NO off

Example:

```
if (i8092MF_GET_DI(1, AXIS_X, 1) == YES)
{
    //get the status of limit+ sensor of X axis on module 1
}
```

- **WORD** `i8092MF_GET_DI_ALL`(**BYTE** *cardNo*, **WORD** *axis*)

Description:

This function reads All digital inputs (DI) status.

Parameters:

cardNo: Module number

axis: Axis (Please refer to Table 2-1)

The axis can be either X and Y

Return: a 16 bits value (0=Low,1=High)

bit 0	NHOME signal
bit 1	HOME signal
bit 2	Z-PHASE signal
bit 3	EMG signal(Only AXIS_X)
bit 4	EXP+ signal
bit 5	EXP- signal
bit 6	READY(INPOS) signal
bit 7	ALARM signal
bit 8	N/A
bit 9	N/A
bit 10	N/A
bit 11	IN3 signal
bit 12	N/A
bit 13	N/A
bit 14	LMT+ signal
bit 15	LMT- signal

Example:

```
WORD DI_Flag=i8092MF_GET_DI_ALL(1, AXIS_X) ;  
    // get all status of module 1 ◦
```

3.6 Reading and Clearing the ERROR Status

- **BYTE** i8092MF_GET_ERROR(**BYTE** *cardNo*)

Description:

This function checks whether an error occurs or not.

Parameters:

cardNo: Module number

Return:

YES: Some errors happened.
Please use i8092MF_GET_ERROR_CODE () to get more information. If *GET_ERROR_CODE* =256, it means that the motion stop was due to the “STOP” command, not because an error happened. Please refer to **6.5.5** and following **example** to clear ERROR.

NO: No error.

EXAMPLE:

```
if (i8092MF_GET_ERROR(1) == YES)
{
    //read module 1 and ERROR is found
    WORD ErrorCode_X = i8092MF_GET_ERROR_CODE(1, AXIS_X);
    WORD ErrorCode_Y = i8092MF_GET_ERROR_CODE(1, AXIS_Y);
    if ((ErrorCode_X || ErrorCode_Y) == 256)
    {
        //It means that motion was stopped due to the stop command was
        issued, not because any error happened. Please take some actions to
        clear the malfunction; then clear the STOP status.
        i8092MF_CLEAR_STOP(1);
    }
}
```

- **WORD** i8092MF_GET_ERROR_CODE(**BYTE** *cardNo*, **WORD** *axis*)

Description:

This function reads the ERROR status.

Parameters:

cardNo: Module number
axis: Axis (Please refer to Table 2-1)
The axis can be either X and Y

Return:

0 → no error

For non-zero return values, please refer to the following table. If there are not only one errors, the return value becomes the sum of these error code values.

For example, a return code **48** means that ALARM and EMGERENCY occurs at the same time.

Error Code	Cause of stop	Explanation
1	SOFT LIMIT+	Occurs when the forward software limit is asserted
2	SOFT LIMIT-	Occurs when the reverse software limit is asserted
4	LIMIT+	Occurs when the forward hardware limit is asserted
8	LIMIT-	Occurs when the reverse hardware limit is asserted
16	ALARM	Occurs when the ALARM is asserted
32	EMERGENCY	Occurs when the EMG is asserted
64	Reserved	Reserved
128	HOME	Occurs when both Z phase and HOME are asserted
256	refer to 6.5.4	Occurs when the EMG(software) is asserted

Example:

```
if (i8092MF_GET_ERROR_CODE(1, AXIS_X) & 10 )
{
    //Check if either the software limit or hardware limit (2+8)
    //in the reverse direction is asserted.
}
```

3.7 Setting the general Dinigtal output

- **void i8092MF_SET_OUT0(BYTE cardNo, WORD axis, WORD nLevel)**

Description:

This Function sets the Digital Output status.

Paramenter:

cardNo: Module number
axis: Axis (Please refer to Table 2-1)
The axis can be either X and Y
nLevel: DO output: 0=OFF,1=ON

Return: no

Example:

```
i8092MF_SET_OUT0 (1, AXIS_XY, 1);
//set the DO of X and Y to ON ◦
```

4 FRnet Functions (for i8092F only)

4.1 Read FRnet DI Signals

- **WORD** i8092MF_FRNET_IN(**BYTE** cardNo, **WORD** wRA)

Description:

This function reads the FRnet digital input signals. **RA** means the *Receiving Address* which can be one of the legal group number of FRnet. One group comprises 16 bits data. Therefore, total 128 DI can be defined for one FRnet interface.

Parameters:

cardNo: Module number
wRA: Group number, range 8~15
Note: 0~7 are used for digital outputs

Return:

WORD 16-bit DI data.

Example:

```
WORD IN_Data;  
IN_Data = i8092MF_FRNET_IN(1, 8);  
//Read the 16-bit DI which is on module 1 and the group number is 8.
```

4.2 Write data to FRnet DO

- `void i8092MF_FRNET_OUT(BYTE cardNo, WORD wSA, WORD data)`

Description:

This function write data to the FRnet digital output. **SA** means the **Sending Address** which can be one of the legal group number of FRnet. One group comprises 16 bits data. Therefore, total 128 DO can be defined for one FRnet interface.

Parameters:

<i>cardNo</i> :	Module number
<i>wSA</i> :	Group number, range 0~7 Note: 8~15 are used by digital inputs
<i>data</i> :	16-bit data

Return:

None

Example:

```
i8092MF_FRNET_OUT(1, 0, 0xffff);  
//Write 0xffff to the 16-bit DO which is on module 1 and the group number is 0.
```

5 Auto Homing

The I-8092F module provides an automatic homing function. After setting the appropriate parameters, the assigned axes are able to perform automatic homing. Settings are required to be made in four steps for performing the automatic HOME search:

- Search for the near home sensor (NHOME) at a normal speed (V).
- Search for the HOME sensor at low speed (HV).
- Search for the Encoder Z-phase (index) at low speed (HV).
- Move a specified number of offset pulses to the predefined origin point at normal speed (V).

Some steps can be omitted. A detailed description of the related functions is provided in the following sections. Fully automated homing can reduce both programming time and CPU processing time.

5.1 Setting the Homing Speed

- `void i8092MF_SET_HV(BYTE cardNo, WORD axis, DWORD data)`

Description:

This function sets the homing speed.

Parameters:

<i>cardNo</i> :	Module number
<i>axis</i> :	Axis or axes (Please refer to Table 2-1)
<i>data</i> :	Homing speed (in PPS)

Return:

None

EXAMPLE:

```
i8092MF_SET_HV(1, AXIS_X, 500);  
//set the homing speed of the X axis on module 1 to 500 PPS.
```

5.2 Using an Limit Switch as the HOME sensor

- **void** i8092MF_HOME_LIMIT(**BYTE** *cardNo*, **WORD** *axis*, **WORD** *nType*)

Description:

This function sets the Limit Switch to be used as the HOME sensor.

Parameters:

cardNo: Module number
axis: Axis axes (Please refer to Table 2-1)
nType: 0: Does not use the LIMIT SWITCH as the HOME sensor;
1: Use the LIMIT SWITCH as the HOME sensor

Return:

None

EXAMPLE:

```
i8092MF_HOME_LIMIT(1, AXIS_X, 0);  
//Do not use the Limit Switch as the HOME sensor.
```

5.3 Setting the Homing Mode

- **void** i8092MF_SET_HOME_MODE(**BYTE** *cardNo*, **WORD** *axis*, **WORD** *nStep1*,
WORD *nStep2*, **WORD** *nStep3*, **WORD** *nStep4* , **long** *data*)

Description:

This function sets the homing method and other related parameters.

Parameters:

cardNo: Module number
axis: Axis or axes (Please refer to Table 2-1)
nStep1: 0: Step 1 is not executed
1: Moves in a positive direction
2: Moves in a negative direction
nStep2: 0: Step 2 is not executed
1: Moves in a positive direction
2: Moves in a negative direction
nStep3: 0: Step 3 is not executed
1: Moves in a positive direction

nStep4: 2: Moves in a negative direction
 0: Step 4 is not executed
 1: Moves in a positive direction
 2: Moves in a negative direction

data: Offset value (0 ~ 2,147,483,647)

The Four Steps Required for Automatic Homing

Step	Action	Speed	Sensor
1	Searching for the Near Home sensor	V	NHOME (IN0)
2	Searching for the HOME sensor	HV	HOME (IN1)
3	Searching for the encoder Z-phase signal	HV	Z-phase (IN2)
4	Moves to the specified position	V	

Return:
 None

Example:

//Use the following functions to set the homing mode of the X axis.

```
i8092MF_SET_V(1, 0x1, 20000);
i8092MF_SET_HV(1, 0x1, 500);
i8092MF_SET_HOME_MODE(1, 0x1, 2, 2, 1, 1, 3500);
i8092MF_HOME_START(1, 0x1); //start auto-homing.
i8092MF_WAIT_HOME(1, 0x1); //wait until homing is completed.
```

Step	Input Signal	Direction	Speed
1	Near HOME (IN0) is active	-	20000 PPS (V)
2	HOME (IN1) is active	-	500 PPS (HV)
3	Z-phase (IN2) is active	+	500 PPS (HV)
4	No sensor is required. Move 3500 pulses along the X axis.	+	20000 PPS (V)

5.4 Starting the Homing Sequence

- **void** i8092MF_HOME_START(**BYTE** *cardNo*, **WORD** *axis*)

Description:

This function starts the home search of assigned axes.

Parameters:

cardNo: Module number
axis: Axis or axes (Please refer to Table 2-1)

Return:

None

Example:

```
i8092MF_HOME_START(1, AXIS_X);  
//start the automatic homing sequence for the X axis on module 1.
```

5.5 Waiting for the Homing sequence to be Completed

- **BYTE** i8092MF_HOME_WAIT(**BYTE** *cardNo*, **WORD** *axis*)

Description:

This function assigns commands to be performed while waiting for the automatic home search of all assigned axes to be completed.

Parameters:

cardNo: Module number
axis: Axis axes (Please refer to Table 2-1)

Return:

YES The Homing sequence has been completed.
NO The Homing sequence is not complete.

Example:

```
if (i8092MF_HOME_WAIT(1, AXIS_X) == NO)  
{  
    //perform some actions here if the X axis on module 1 has not completed  
    //its homing sequence.  
}
```

6 General Motion Control

6.1 Independent Axis Motion Control

- The motion of each axis can be started independently.
- Two axes are moving at the same time.
- Each axis is moving independently.
- Each axis can be commanded to change motion, such as changing the number of pulses or the speed.
- Each axis can be commanded to stop slowly or suddenly to meet the individual requirements.

6.1.1 Setting the Acceleration/Deceleration Mode

- `void i8092MF_NORMAL_SPEED(BYTE cardNo, WORD axis , WORD nMode)`

Description:

The function sets the speed mode.

Parameters:

cardNo: Module number

axis: Axis (Please refer to Table 2-1)

nMode:

0 → Symmetric T-curve (Please set SV, V, A, and AO)

1 → Symmetric S-curve (Please set SV, V, K, and AO)

2 → Asymmetric T-curve (Please set SV, V, A, D, and AO)

Return:

None

Example:

```
BYTE cardNo=1; //select module 1.
i8092MF_SET_MAX_V(cardNo, AXIS_XY, 20000);
//set the max. speed of XY axes to 20K PPS.

//=====================================================
i8092MF_NORMAL_SPEED(cardNo, AXIS_XY, 0);
//use a symmetric T-curve for all axes on module 1.
i8092MF_SET_V(cardNo, AXIS_XY, 2000);
//set the speed of all axes on module 1 to 2000 PPS.
i8092MF_SET_A(cardNo, AXIS_XY,1000);
```

```

//set the acceleration of all axes on module 1 to 1000 PPS/Sec.
i8092MF_SET_SV(cardNo, AXIS_XY, 2000);
//set the start speed of all axes on module 1 to 2000 PPS.
i8092MF_SET_AO(cardNo, AXIS_XY, 9);
//set the number of remaining offset pulses for all axes to 9 pulses.
i8092MF_FIXED_MOVE(cardNo, AXIS_XY, 10000);
//move all axes on module 1 for 10000 pulses.

//=====
i8092MF_NORMAL_SPEED(cardNo, AXIS_XY,1);
//use a symmetric S-curve for all axes on module 1.
i8092MF_SET_V(cardNo, AXIS_XY, 2000);
//set the speed of all axes on module 1 to 2000 PPS.
i8092MF_SET_K(cardNo, AXIS_XY, 50);
//set the acceleration rate of all axes on module 1 to 500 PPS/Sec^2.
i8092MF_SET_SV(cardNo, AXIS_XY, 200);
//set the start speed of all axes on module 1 to 200 PPS.
i8092MF_SET_AO(cardNo, AXIS_XY, 9);
//set the number of remaining offset pulses to 9 pulses for all axes.
i8092MF_FIXED_MOVE(cardNo, AXIS_XY, -10000);
//move all axes on module 1 for 10000 pulses in reverse direction.
//=====
i8092MF_NORMAL_SPEED(cardNo, AXIS_XY,2);
//use an asymmetric T-curve for all axes on module 1.
i8092MF_SET_V(cardNo, AXIS_XY, 2000);
//set the speed of all axes on module 1 to 2000 PPS.
i8092MF_SET_A(cardNo, AXIS_XY,1000 );
//set the acceleration of all axes on module 1 to 1000 PPS/Sec.
i8092MF_SET_D(cardNo, AXIS_XY, 500);
//set the deceleration of all axes on module 1 to 500 PPS.
i8092MF_SET_SV(cardNo, AXIS_XY, 200);
//set the start speed of all axes on module 1 to 200 PPS.
i8092MF_SET_AO(cardNo, AXIS_XY, 9);
//set the number of remaining offset pulses to 9 pulses for all axes.
i8092MF_FIXED_MOVE(cardNo, axis, 10000);
//move all axes on module 1 for 10000 pulses.

```

Note: Relevant parameters must be set to achieve the desired motion.

6.1.2 Setting the Start Speed

- `void i8092MF_SET_SV(BYTE cardNo, WORD axis, DWORD data)`

Description:

This function sets the start speed for the assigned axes.

Parameters:

cardNo: Module number
axis: Axis or axes (Please refer to Table 2-1)
data: The range is the same as for speed, and must not be zero or larger than the maximum speed. The maximum value is 4,000,000 PPS. For interpolation, set the speed value for axis1 is enough.

Return:

None

Example:

```
i8092MF_SET_SV(1, AXIS_X, 1000);  
//set the starting speed for the X axis on module 1 to 1000 PPS.
```

6.1.3 Setting the Desired Speed

- `void i8092MF_SET_V(BYTE cardNo, WORD axis, DWORD data)`

Description:

This function sets the desired speed for the assigned axes.

Parameters:

cardNo: Module number
axis: Axis or axes (Please refer to Table 2-1)
data: The range is the same as for speed, and must not be zero or larger than the maximum speed. The maximum value is 4,000,000 PPS. For interpolation, set the speed value for axis1 is enough.

Return:

None

Example:

```
i8092MF_SET_V(1, AXIS_X, 120000);  
//set the speed for the X axis on module 1 to 120000 PPS.
```

6.1.4 Setting the Acceleration

- `void i8092MF_SET_A(BYTE cardNo, WORD axis, DWORD data)`

Description:

This function sets the acceleration value for the assigned axes.

Parameters:

cardNo: Module number
axis: Axis or axes (Please refer to Table 2-1)
data: The acceleration value. The units are PPS/Sec. This value is related to the maximum speed value defined by `i8092MF_SET_MAX_V()` function. The maximum available acceleration value is $MAX_V * 125$. The minimum acceleration value is $MAX_V \div 64$, and all other acceleration values are the integral multipliers of this value. The practical value for application depends on the capability of the motor drive and motor.

Return:

None

Example:

```
i8092MF_SET_MAX_V(1, AXIS_X, 20000);  
//set the maximum speed value of the X axis as 20,000 PPS.  
//therefore, do not set any acceleration value that is larger than  
//20,000*125 PPS/sec. And 20,000 *125 = 2,500,000.  
i8092MF_SET_A(1, AXIS_X, 100000);  
//set the acceleration value of the X axis on module 1 to 100K PPS/Sec.
```

6.1.5 Setting the Deceleration

- `void i8092MF_SET_D(BYTE cardNo, WORD axis, DWORD data)`

Description:

This function sets the deceleration value for the assigned axes.

Parameters:

cardNo: Module number
axis: Axis or axes (Please refer to Table 2-1)

data: The deceleration value. The units are PPS/Sec. This value is related to the maximum speed value defined by `i8092MF_SET_MAX_V()` function. The maximum available deceleration value is $MAX_V * 125$. The minimum deceleration value is $MAX_V \div 64$, and all other deceleration values are the integral multipliers of this value. The practical value for application depends on the capability of the motor drive and motor.

Return:
None

Example:

```
i8092MF_SET_MAX_V(1, AXIS_X, 20000);  
//set the maximum speed value of the X axis as 20,000 PPS.  
//therefore, do not set any deceleration value that is larger than  
//20,000*125 PPS/sec. And 20,000 *125 = 2,500,000.  
i8092MF_SET_D(1, AXIS_X, 100000);  
//set the deceleration value of the X axis on module 1 to 100K PPS/Sec.
```

6.1.6 Setting the Acceleration Rate

- `void i8092MF_SET_K(BYTE cardNo, WORD axis, DWORD data)`

Description:

The function sets the acceleration rate (i.e., Jerk) value for the assigned axes.

Parameters:

cardNo: Module number
axis: Axis or axes (Please refer to Table 2-1)
data: The acceleration rate (jerk) value. The units are PPS/Sec². This value is related to the maximum speed value defined by `i8092MF_SET_MAX_V()` function. The maximum available acceleration rate value is `MAX_V * 781.25`. The minimum acceleration value is `MAX_V * 0.0119211`, and all other acceleration values are the integral multipliers of this value. The practical value for application depends on the capability of the motor drive and motor. **Note: since the DWORD can not represent the maximum value; therefore, this value is given by dividing the desired value by 10.**

Return:

None

Example:

```
i8092MF_SET_MAX_V(1, AXIS_X, 20000);  
//set the maximum speed value of the X axis as 20,000 PPS.  
//therefore, do not set any jerk value that is larger than  
//20,000*781.25 PPS/sec^2. And 20,000 *781.25 = 15,625,000.  
i8092MF_SET_K(1, AXIS_X, 1000);  
//set the acceleration rate value of the X axis on module 1 to  
//1,000*10 (= 10,000) PPS/Sec^2.
```

6.1.7 Setting the Value of the Remaining Offset Pulses

- `void i8092MF_SET_AO(BYTE cardNo, WORD axis, short int data)`

Description:

This function sets the number of remaining offset pulses for the assigned axes. Please refer to the figure below for a definition of the remaining offset pulse value.

Parameters:

cardNo: Module number
axis: Axis or axes (Please refer to Table 2-1)
data: The number of remaining offset pulses. (-32,768 ~ +32,767)

Return:

None

Example:

```
i8092MF_SET_AO(1, AXIS_X, 200);  
//set the number of remaining offset pulses for the X axis on  
//module 1 to 200 pulses.
```

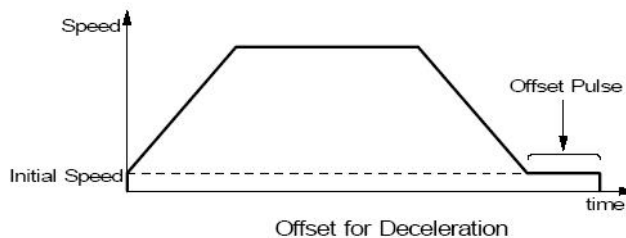

6.1.8 Fixed Pulse Output

- **BYTE** i8092MF_FIXED_MOVE(**BYTE** cardNo, **WORD** axis, **long** data)

Description:

Command a point-to-point motion for several independent axes.

Parameters:

cardNo: Module number
axis: Axis (Please refer to Table 2-1.)
The axis can be either X and Y
data: Pulses (-268,435,455 ~ + 268,435,455)

Return:

YES Some errors happen. Use i8092MF_GET_ERROR_CODE () to identify the errors.
NO No error.

Example:

```
BYTE cardNo=1; //select module 1
i8092MF_SET_MAX_V(cardNo, AXIS_XY, 20000);
//set the max. velocity of all axes on module 1 to be 20K PPS
i8092MF_NORMAL_SPEED(cardNo, AXIS_XY, 0);
//set the speed profile of all axes on module 1 to be symmetric T-curve
i8092MF_SET_V(cardNo, AXIS_XY, 2000);
//set the speed of all axes on module 1 to be 2000 PPS
i8092MF_SET_A(cardNo, AXIS_XY,1000);
//set the acceleration value of all axes on module 1 to be 1000 PPS/S
i8092MF_SET_SV(cardNo, AXIS_XY, 2000);
//set the start velocity of all axes on module 1 to be 2000 PPS
i8092MF_SET_AO(cardNo, AXIS_XY, 9);
//set the remaining offset pulses to be 9 PPS
i8092MF_FIXED_MOVE(cardNo, AXIS_XY, 10000);
// move 10000 Pulses for each axis on module 1
```

6.1.9 Continuous Pulse Output

- **BYTE** i8092MF_CONTINUE_MOVE(**BYTE** cardNo, **WORD** axis, **long** data)

Description:

This function issues a continuous motion command for several independent axes.

Parameters:

cardNo: Module number
axis: Axis or axes (Please refer to Table 2-1)
The axis can be either X and Y
data: The specified speed (positive value for CW motion;
negative value for CCW motion)

Return:

YES An error has occurred.
Use the i8092MF_GET_ERROR_CODE() function to identify
the errors.
NO No error.

Example:

```
BYTE cardNo=1; //select module 1
i8092MF_SET_MAX_V(cardNo, AXIS_XY, 20000);
//set the maximum speed of all axes on module 1 to 20K PPS.
i8092MF_NORMAL_SPEED(cardNo, AXIS_XY, 0);
//set the speed profile for all axes as a symmetric T-curve.
i8092MF_SET_V(cardNo, AXIS_XY, 2000);
//set the speed of all axes on module 1 to 2000 PPS.
i8092MF_SET_A(cardNo, AXIS_XY, 1000);
//set the acceleration value of all axes to 1000 PPS/S.
i8092MF_SET_SV(cardNo, AXIS_XY, 2000);
//set the start velocity of all axes to 2000 PPS
i8092MF_CONTINUE_MOVE(cardNo, AXIS_XY, 1000);
//move all axes on module 1 at a speed of 1000 PPS.
```

6.2 Interpolation Commands

I-8092/F is a motion module of 2-axes, so first axis of interpolation is fixed X-axis and second axis of interpolation is Y-axis.

6.2.1 Setting the Speed and Acc/Dec Mode for Interpolation

- `void i8092MF_VECTOR_SPEED(BYTE cardNo, WORD nMode)`

Description:

This function assigns the mode of vector speed of interpolation. Each interpolation mode will refer to construct a working coordinate system. The X-axis necessarily have to be the first axis. Different modes need different settings. Please refer to the mode definitions.

Parameters:

<i>cardNo:</i>	Module number
<i>nMode:</i>	0 → 2-axis linear or circular motion at a constant vector speed (Set VV and VSV; and VV=VSV)
	1 → 2-axis linear motion using a symmetric T-curve velocity profile (set VSV, VV, VA, and VAO)
	2 → 2-axis linear motion using a symmetric S-curve velocity profile (set VSV, VV, VK, and VAO)
	3 → 2-axis linear motion using an asymmetric T-curve velocity profile (set VSV, VV, VA, VD, and VAO)
	4 → 2-axis linear motion using an asymmetric S-curve velocity profile (set VSV, VV, VK, VL, and VAO)
	5 → 2-axis circular motion using a symmetric T-curve velocity profile (set VSV, VV, VA, and VAO)
	6 → 2-axis circular motion using an asymmetric T-curve velocity profile (set VSV, VV, VA, VD, and VAO)

Return:

None

Example:

```
BYTE cardNo=1; //select module 1.
i8092MF_SET_MAX_V(cardNo, AXIS_XY, 20000);
//set the maximum speed of all axes to 20K PPS.

//=====
i8092MF_VECTOR_SPEED(cardNo, 0);
//set module 1 to perform 2-axis linear or circular motion
//at a constant vector speed.
i8092MF_SET_VSV(cardNo, 1000);
```

```

//set the starting vector speed to 1000 PPS.
i8092MF_SET_VV(cardNo, 1000);
//set the vector speed to 1000 PPS.
i8092MF_LINE_2D(1, 12000, 10000);
//execute the 2-axis linear interpolation motion.

//=====
i8092MF_DEC_ENABLE(cardNo);
//enable the deceleration function.
i8092MF_VECTOR_SPEED(cardNo, 1);
//set module 1 to perform 2-axis linear motion using a symmetric
//S-curve velocity profile.
i8092MF_SET_VSV(cardNo, 500);
//set the starting vector speed to 500 PPS.
i8092MF_SET_VV(cardNo, 2000);
//set the vector speed to 2000 PPS.
i8092MF_SET_VA(cardNo, 1000);
//set the vector acceleration to 1000 PPS/Sec.
i8092MF_LINE_2D(cardNo, 20000, 10000);
//execute the 2-axis linear interpolation motion.

//=====
i8092MF_VECTOR_SPEED(cardNo, 2);
//2-axis linear motion using a symmetric S-curve velocity profile.
i8092MF_SET_VSV(cardNo, 200);
//set the starting vector speed to 200 PPS.
i8092MF_SET_VV(cardNo, 2000);
//set the vector speed to 2000 PPS.
i8092MF_SET_VK(cardNo, 50);
//set the acceleration rate to 500 PPS/Sec.
i8092MF_SET_VAO(cardNo, 20);
//set the value of remaining offset pulses to 20.
i8092MF_LINE_2D(cardNo, 10000, 10000);
//execute the 2-axis linear interpolation motion.

//=====
i8092MF_DEC_ENABLE(cardNo);
//enable the deceleration function.
i8092MF_VECTOR_SPEED(cardNo, 3);
//2-axis linear motion using an asymmetric T-curve velocity profile.
i8092MF_SET_VSV(cardNo, 100);
//set the start vector speed to 100 PPS.
i8092MF_SET_VV(cardNo, 2000);
//set the vector speed to 2000 PPS.
i8092MF_SET_VA(cardNo, 1000);
//set the vector acceleration to 1000 PPS/Sec.
i8092MF_SET_VD(cardNo, 500);

```

```

//set the vector deceleration to 500 PPS/Sec.
i8092MF_SET_VAO(cardNo, 20);
//set the value of remaining offset pulses to 20.
i8092MF_LINE_2D(cardNo, 10000, 5000);
//execute the 2-axis linear interpolation motion.

//=====
long fp1=4000;
long fp2=10000;
int sv=200;
int v=2000;
i8092MF_SET_MAX_V(cardNo, AXIS_XY, 8000);
i8092MF_VECTOR_SPEED(cardNo, 4);
//2-axis linear motion using an asymmetric S-curve velocity profile.
i8092MF_SET_VSV(cardNo, sv);
//set the starting velocity to sv PPS.
i8092MF_SET_VV(cardNo, v);
//set the vector speed to v PPS.
i8092MF_SET_VK(cardNo, 50);
//set the acceleration rate to 500 PPS/Sec^2.
i8092MF_SET_VL(cardNo, 30);
//set the deceleration rate to 300 PPS/Sec^2.
i8092MF_SET_VAO(cardNo, 20);
//set the value of remaining offset pulses to 20.
i8092MF_LINE_2D(cardNo, fp1, fp2);
//execute the 2-axis linear motion.

//=====
long fp1=11000;
long fp2=9000;
long c1=10000;
long c2=0;
int sv=100;
int v=3000;
int a=5000;
int d=5000;
i8092MF_SET_MAX_V(cardNo, AXIS_XY, 8000);
i8092MF_VECTOR_SPEED(cardNo, 5);
//2-axis circular motion using a symmetric T-curve velocity profile
i8092MF_SET_VSV(cardNo, sv);
//set the starting vector speed to sv PPS.
i8092MF_SET_VV(cardNo, v);
//set vector speed to v PPS.
i8092MF_SET_VA(cardNo, a);
//set the vector acceleration to a PPS/Sec.
i8092MF_SET_VAO(cardNo, 0);
//set the value of remaining offset pulses to 0 Pulse.

```

```

i8092MF_ARC_CW(cardNo, c1,c2, fp1, fp2);
//execute the 2-axis CW circular motion.

//=====
long c1=300;
long c2=0;
int sv=100;
int v=3000;
int a=125;
int d=12;
i8092MF_SET_MAX_V(cardNo, AXIS_XY, 8000);
i8092MF_VECTOR_SPEED(cardNo, 6);
//2-axis circular motion using an asymmetric T-curve velocity
//profile.
i8092MF_SET_VSV(cardNo, sv);
//set the starting vector speed to sv PPS.
i8092MF_SET_VV(cardNo, v);
//set vector speed to v PPS.
i8092MF_SET_VA(cardNo, a);
//set acceleration to a PPS/Sec.
i8092MF_SET_VD(cardNo, d);
//set the deceleration to d PPS/Sec.
i8092MF_SET_VAO(cardNo, 0);
//set the value of remaining offset pulses to 0.
i8092MF_CIRCLE_CW(cardNo, c1, c2);
//execute the 2-axis CW circular motion.

```

Note: Relevant parameters should be set before issuing the motion command.

6.2.2 Setting the Vector Starting Speed

- `void i8092MF_SET_VSV(BYTE cardNo, DWORD data)`

Description:

This function sets the starting speed of the principle X-axis for the interpolation motion.

Parameters:

cardNo: Module number
data: The vector starting speed value (in PPS)

Return:

None

Example:

```
i8092MF_SET_VSV(1, 1000);  
//set the starting speed of the axis 1 for the interpolation motion  
//on module 1 to 1000 PPS.
```

6.2.3 Setting the Vector Speed

- `void i8092MF_SET_VV(BYTE cardNo, DWORD data)`

Description:

This function sets the vector speed of the interpolation motion. Users do not need to assign any axes on this function.

Parameters:

cardNo: Module number
data: The vector speed value (in PPS)

Return:

None

Example:

```
i8092MF_SET_VV(1, 120000);  
//set the vector speed of the interpolation on module 1  
//to 120000 PPS.
```

6.2.4 Setting the Vector Acceleration

- `void i8092MF_SET_VA(BYTE cardNo, DWORD data)`

Description:

This function sets the vector acceleration for interpolation motion. Users do not have to assign any axes on this function.

Parameters:

cardNo: Module number
data: The vector acceleration value (in PPS/Sec). The units are PPS/Sec. This value is related to the maximum speed value defined by `i8092MF_SET_MAX_V()` function. The maximum available acceleration value is $MAX_V * 125$. The minimum acceleration value is $MAX_V \div 64$, and all other acceleration values are the integral multipliers of this value. The practical value for application depends on the capability of the motor drive and motor.

Return:

None

Example:

```
i8092MF_SET_MAX_V(1, AXIS_X, 20000);  
//set the maximum speed value of the X axis as 20,000 PPS.  
//therefore, do not set any acceleration value that is larger than  
//20,000*125 PPS/sec. And 20,000 *125 = 2,500,000.  
i8092MF_SET_VA(1, 100000);  
//set the vector acceleration of the interpolation motion  
//on module 1 to 100K PPS/Sec.
```

6.2.5 Setting the Vector Deceleration Value

- `void i8092MF_SET_VD(BYTE cardNo, DWORD data)`

Description:

This function sets the deceleration value for the interpolation motion.

Parameters:

cardNo: Module number
data: The vector deceleration value (in PPS/Sec). This value is related to the maximum speed value defined by `i8092MF_SET_MAX_V()` function. The maximum available deceleration value is $MAX_V * 125$. The minimum deceleration value is $MAX_V \div 64$, and all other deceleration values are the integral multipliers of this value. The practical value for application depends on the capability of the motor drive and motor.

Return:

None

Example:

```
i8092MF_SET_MAX_V(1, AXIS_X, 20000);  
//set the maximum speed value of the X axis as 20,000 PPS.  
//therefore, do not set any deceleration value that is larger than  
//20,000*125 PPS/sec. And 20,000 *125 = 2,500,000.  
i8092MF_SET_VD(1, 100000);  
//set the vector deceleration value of interpolation motion  
//on module 1 to 100K PPS/Sec.
```

6.2.6 Setting the Vector Acceleration Rate

- `void i8092MF_SET_VK(BYTE cardNo, DWORD data)`

Description:

Set the acceleration rate (jerk) value for interpolation motion.

Parameters:

cardNo: Module number

data: The acceleration rate (jerk) value. The units are PPS/Sec². This value is related to the maximum speed value defined by `i8092MF_SET_MAX_V()` function. The maximum available acceleration rate value is `MAX_V * 781.25`. The minimum acceleration value is `MAX_V * 0.0119211`, and all other acceleration values are the integral multipliers of this value. The practical value for application depends on the capability of the motor drive and motor. **Note: since the DWORD can not represent the maximum value; therefore, this value is given by dividing the desired value by 10.**

Return:

None

Example:

```
i8092MF_SET_MAX_V(1, AXIS_X, 20000);  
//set the maximum speed value of the X axis as 20,000 PPS.  
//therefore, do not set any jerk value that is larger than  
//20,000*781.25 PPS/sec^2. And 20,000 *781.25 = 15,625,000.  
i8092MF_SET_VK(1, 10000);  
//set the acceleration rate of the interpolation motion on module  
// 1 to 10,000 PPS/ Sec^2.
```

6.2.7 Setting the Number of the Remaining Offset Pulses

- `void i8092MF_SET_VAO(BYTE cardNo, short int data)`

Description:

Setting this value will cause the motion control chip to start deceleration earlier. The remaining offset pulses will be completed at low speed to allow the controller to stop immediately when the offset pulse value has been reached. Please refer to the figure below for more information.

Parameters:

cardNo: Module number
data: The number of remaining offset pulses (-32,768 ~ +32,767)

Return:

None

Example:

```
i8092MF_SET_VAO(1, 200);  
//set the number of remaining offset pulse value on module 1 to 200.
```

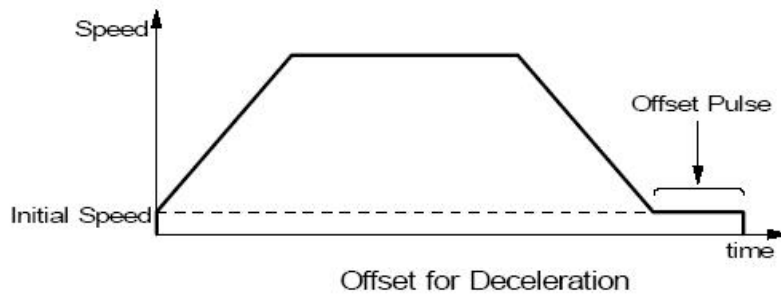

6.2.8 2-Axis Linear Interpolation Motion

- **BYTE** `i8092MF_LINE_2D`(**BYTE** *cardNo*, **long** *fp1*, **long** *fp2*)

Description:

This function executes a 2-axis linear interpolation motion.

Parameters:

cardNo: Module number
fp1: The displacement of the X-axis in Pulses
(-8,388,607 ~ +8,388,607)
fp2: The displacement of the Y-axis in Pulses
(-8,388,607 ~ +8,388,607)

Return:

YES An error has occurred.
Use the `i8092MF_GET_ERROR_CODE()` function to identify the error.
NO No errors.

Example:

```
i8092MF_LINE_2D(1, 12000, 10000);  
//execute the 2-axis linear interpolation motion on module 1.
```

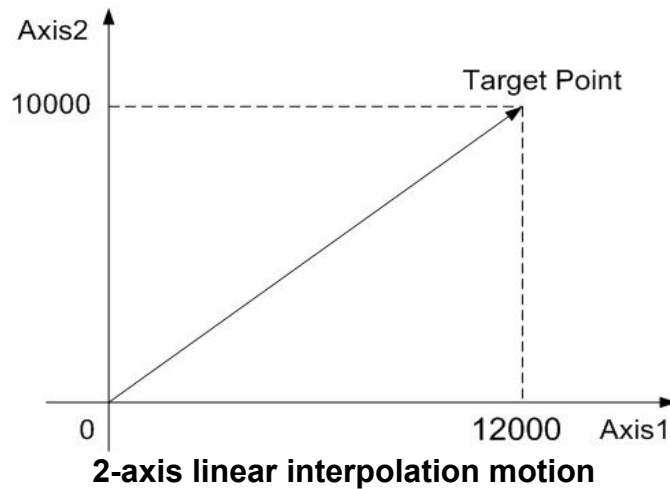

6.2.9 2-Axis Circular Interpolation Motion (an Arc)

- **BYTE** `i8092MF_ARC_CW`(**BYTE** *cardNo*, **long** *cp1*, **long** *cp2*, **long** *fp1*, **long** *fp2*)

Description:

This function executes a 2-axis circular interpolation motion in a clockwise (CW) direction.

Parameters:

cardNo: Module number
cp1: The relative position of the center to the current position of X-axis in pulses. (-8,388,607 ~ +8,388,607)
cp2: The relative position of the center to the current position of Y-axis in pulses. (-8,388,607 ~ +8,388,607)
fp1: The displacement of the X-axis in pulses. (-8,388,607 ~ +8,388,607)
fp2: Displacement of the Y-axis in pulses. (-8,388,607 ~ +8,388,607)

Return:

YES An error has occurred.
Use the `i8092MF_GET_ERROR_CODE ()` function to identify the error.
NO No errors.

Example:

```
i8092MF_ARC_CW(1, -5000, -5000, -10000, -10000);  
//Issues a command to perform a circular motion (an arc)  
//in a CW direction. Please refer to the following figure.
```

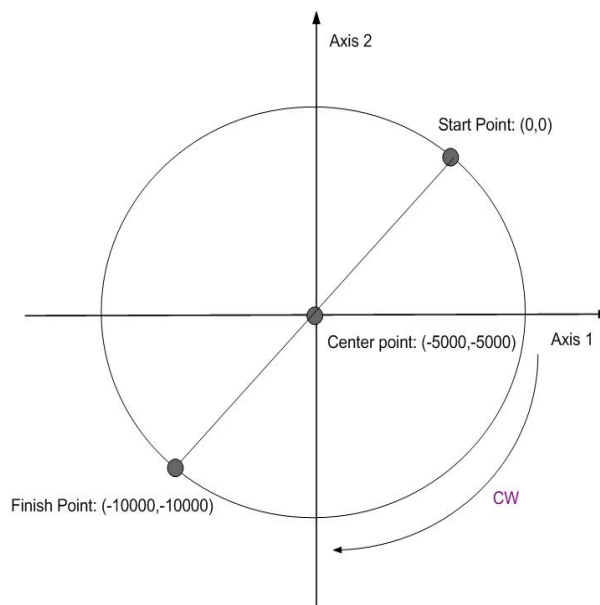

2-axis circular motion in a CW direction

- **BYTE** i8092MF_ARC_CCW(**BYTE** cardNo, **long** cp1, **long** cp2, **long** fp1, **long** fp2)

Description:

This function execute a 2-axis circular interpolation motion in a counter-clockwise (CCW) direction.

Parameters:

cardNo: Module number
cp1: The relative position of the center to the current position of X-axis in pulses. (-8,388,607 ~ +8,388,607)
cp2: The relative position of the center to the current position of Y-axis in pulses. (-8,388,607 ~ +8,388,607)
fp1: The displacement of the X-axis in pulses. (-8,388,607 ~ +8,388,607)
fp2: Displacement of the Y-axis in pulses. (-8,388,607 ~ +8,388,607)

Return:

YES An error has occurred.
 Use the i8092MF_GET_ERROR_CODE() function to identify the errors.
NO No errors.

Example:

```
i8092MF_ARC_CCW(1, -5000, -5000, -10000, -10000);  

//Issues a command to perform a circular motion (an arc)  

//in a CCW direction. Refer to the following figure.
```

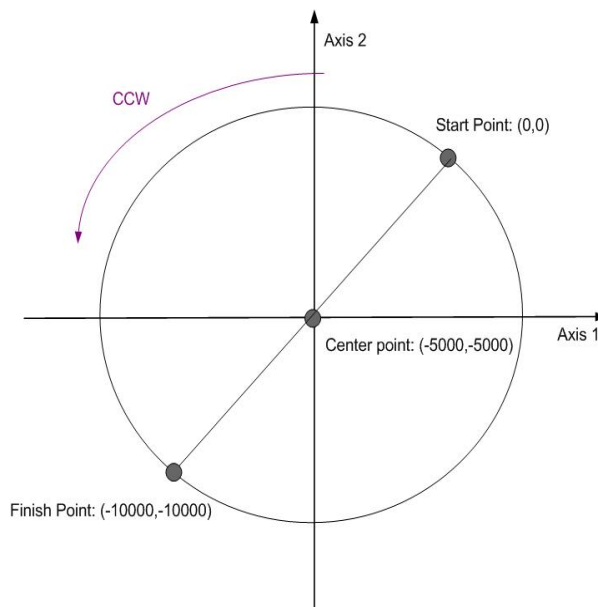

2-axis circular motion in a CCW direction

6.2.10 2-Axis Circular Interpolation Motion

- **BYTE** `i8092MF_CIRCLE_CW`(**BYTE** *cardNo*, **long** *cp1*, **long** *cp2*)

Description:

This function executes a 2-axis circular interpolation motion in a clockwise (CW) direction.

Parameters:

cardNo: Module number
cp1: The relative position of the center to the current position of X-axis in pulses. (-8,388,607 ~ +8,388,607)
cp2: The relative position of the center to the current position of Y-axis in pulses. (-8,388,607 ~ +8,388,607)

Return:

YES An error has occurred.
Use the `i8092MF_GET_ERROR_CODE()` function to identify the errors.
NO No errors.

Example:

```
i8092MF_CIRCLE_CW(1, 0, 10000);  
//execute a circular motion (a complete circle) in a CW direction on module 1.
```

- **BYTE** `i8092MF_CIRCLE_CCW`(**BYTE** *cardNo*, **long** *cp1*, **long** *cp2*)

Description:

This function executes a 2-axis circular interpolation motion in a counter-clockwise (CCW) direction.

Parameters:

cardNo: Module number
cp1: The relative position of the center to the current position of X-axis in pulses. (-8,388,607 ~ +8,388,607)
cp2: The relative position of the center to the current position of Y-axis in pulses. (-8,388,607 ~ +8,388,607)

Return:

YES An error has occurred.
Use the `i8092MF_GET_ERROR_CODE ()` function to identify

NO **the error.**
 No errors

Example:

```
i8092MF_CIRCLE_CCW(1, 0, 10000);  
//execute a circular motion (a circle) in CCW direction  
//on module 1
```

6.3 Continuous Interpolation

If it is broken and stopped , please solve it refer in section 6.5.5 !

6.3.1 2-Axis Rectangular Motion

- **BYTE** `i8092MF_RECTANGLE(`
`BYTE cardNo, WORD nAcc, WORD Sp, WORD nDir, long Lp, long Wp,`
`long Rp, DWORD RSV, DWORD RV, DWORD RA, DWORD RD)`

Description:

Continuous interpolation will be performed to create a rectangular motion, which is formed by 4 lines and 4 arcs. The length of each side can be changed. The radius of each arc is the same and it can also be changed. The deceleration point will be calculated automatically. This is a command macro command that appears in various motion applications. However, it is a software macro-function; therefore, it requires CPU resource to run this function.

Parameters:

<i>cardNo</i> :	Module number
<i>nAcc</i> :	0 → constant vector speed interpolation mode 1 → symmetric T-curve Acc/Dec interpolation mode
<i>Sp</i> :	Start point 0 ~ 7. (Sp0 ~ Sp7 are defined in the following figure)
<i>nDir</i> :	Direction of movement 0: CCW; 1: CW
<i>Lp</i> :	Length in Pulses (1 ~ 8,388,607)
<i>Wp</i> :	Width in Pulses (1 ~ 8,388,607)
<i>Rp</i> :	Radius of each in pulses (1 ~ 8,388,607)
<i>RSV</i> :	Starting speed (in PPS)
<i>RV</i> :	Vector speed (in PPS)
<i>RA</i> :	Acceleration (PPS/Sec)
<i>RD</i> :	Deceleration of the last segment (in PPS/Sec)

Return:

YES	An error has occurred. Use the <code>i8092MF_GET_ERROR_CODE()</code> function to identify the error.
NO	No errors.

Example:

```
BYTE cardNo=1; //select module 1.  
int sv=1000; //starting speed: 1000 PPS.
```

```

int v=10000; //vector speed: 10000 PPS.
int a=5000; //acceleration: 5000 PPS/Sec.
int d=5000; //deceleration: 5000 PPS/Sec.
i8092MF_SET_MAX_V(cardNo, AXIS_XY, 16000);
//set the maximum speed to 16000 PPS.

i8092MF_RECTANGLE(cardNo, AXIS_X, AXIS_Y, 1, 0, 0, 20000, 10000, 1000, sv, v,
a, d);
//execute a rectangular motion on the XY plane

```

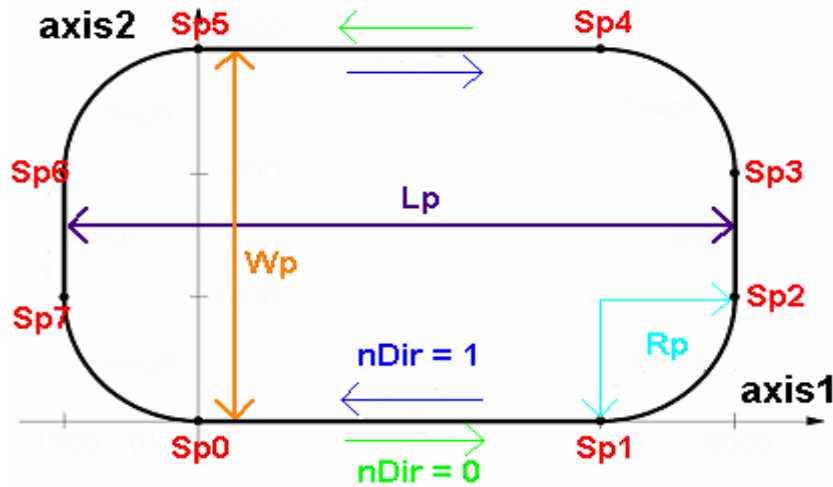

6.3.2 2-Axis Continuous Linear Interpolation

- **BYTE** i8092MF_LINE_2D_INITIAL(**BYTE** cardNo, **DWORD** VSV, **DWORD** VV, **DWORD** VA)

Description:

This function sets the necessary parameters for a 2-axis continuous linear interpolation using symmetric T-curve speed profile.

Parameters:

cardNo:	Module number
VSV:	Starting speed (in PPS)
VV:	Vector speed (in PPS)
VA:	Vector acceleration (PPS/Sec)

Return:

None

Example:

```
i8092MF_LINE_2D_INITIAL(...);  
//This function should be defined before the i8092MF_LINE_2D_CONTINUE()  
//function is used. Please refer to the example of this function.
```

- **BYTE** i8092MF_LINE_2D_CONTINUE(**BYTE** cardNo, **WORD** nType, **long** fp1, **long** fp2)

Description:

This function executes a 2-axis continuous linear interpolation. However, it is a software macro-function; therefore, it requires CPU resource to run this function.

Parameters:

cardNo: Module number
nType: 0: 2-axis linear continuous interpolation
1: end of 2-axis linear continuous interpolation
fp1: The assigned number of pulses for the axis 1 (in Pulses)
(-8,388,607 ~ +8,388,607)
fp2: The assigned number of pulses for the axis 2 (in Pulses)
(-8,388,607 ~ +8,388,607)

Return:

YES An error has occurred.
Use the i8092MF_GET_ERROR_CODE () function to identify the error.
NO No errors.

Example:

```
BYTE cardNo=1; //select module 1.  
int sv=300; //starting speed: 300 PPS.  
int v=18000; //vector speed: 18000 PPS.  
long a=500000; //acceleration: 500000 PPS/Sec.  
int loop1;  
i8092MF_SET_MAX_V(cardNo, AXIS_XY,160000);  
i8092MF_LINE_2D_INITIAL(cardNo, AXIS_X, AXIS_Y, sv, v, a);  
for (loop1=0; loop1<10000; loop1++)  
{  
    i8092MF_LINE_2D_CONTINUE(cardNo, 0, 100, 100);  
    i8092MF_LINE_2D_CONTINUE(cardNo, 0, -100, -100);  
}  
i8092MF_LINE_2D_CONTINUE(cardNo, 1, 100, 100);
```

6.3.3 Multi-Segment Continuous Interpolation (Using Array)

- **BYTE** i8092MF_CONTINUE_INTP(
 BYTE cardNo, **WORD** nAcc, **DWORD** VSV, **DWORD** VV, **DWORD** VA,
 DWORD VD, **BYTE** nType[], **long** cp1[], **long** cp2[], **long** fp1[], **long**
 fp2[])

Description:

This function executes a multi-segment continuous interpolation. Those segments are stored in arrays declared in the arguments. The speed profile can be either a constant speed or a symmetric T-curve. The deceleration point will be calculated automatically. However, it is a software macro-function; therefore, it requires CPU resource to run this function.

Parameters:

cardNo: Module number
nAcc: 0 → a constant speed interpolation. Please set VV.
1 → a symmetric T-curve interpolation. Please set VSV, VV, VA, and VD.
VSV: The starting speed (in PPS)
VV: Interpolation vector speed (in PPS)
VA: Acceleration (in PPS/Sec)
VD: Deceleration (in PPS/Sec)

nType[]: Maximum segment: 1024 (0 ~ 1023). It contains the interpolation commands defined as follows.

- 1 → i8092MF_LINE_2D(**BYTE** cardNo, **long** fp1, **long** fp2);
- 2 → i8092MF_ARC_CW(**BYTE** cardNo, **long** cp1, **long** cp2, **long** fp1, **long** fp2);
- 3 → i8092MF_ARC_CCW(**BYTE** cardNo, **long** cp1, **long** cp2, **long** fp1, **long** fp2);
- 4 → i8092MF_CIRCLE_CW(**BYTE** cardNo, **long** cp1, **long** cp2);
- 5 → i8092MF_CIRCLE_CCW(**BYTE** cardNo, **long** cp1, **long** cp2);
- 7 → It indicates the end of continuous interpolation.

cp1[]: It contains a list of segment center point data at axis 1.
(-8,388,607 ~ +8,388,607)

cp2[]: It contains a list of segment center point data at axis 2.
(-8,388,607 ~ +8,388,607)

fp1[]: This array contains a list of segment end point data at axis 1.
(-8,388,607 ~ +8,388,607)

fp2[]: This array contains a list of segment end point data at axis 2.
(-8,388,607 ~ +8,388,607)

Return:

YES	An error has occurred. Use the <code>i8092MF_GET_ERROR_CODE ()</code> function to identify the error.
NO	No errors.

Example:

```

BYTE cardNo=1; //select module 1.
int sv=100; //set the starting speed to 100 PPS.
int v=3000; //set the speed to 3000 PPS.
int a=2000; //set the acceleration to 2000 PPS/Sec.
int d=2000; //set the deceleration to 2000 PPS/Sec.
i8092MF_SET_MAX_V(cardNo, AXIS_XY, 20000);
//set the maximum speed to 20K PPS.
BYTE nType[10]= { 1, 2, 1, 2, 1,7,0,0,0,0};
long cp1[10]= { 0, 10000, 0, 0, 0,0,0,0,0,0};
long cp2[10]= { 0, 0, 0,-10000, 0,0,0,0,0,0};
long fp1[10]= { 10000, 10000, 1000, 10000,-31000,0,0,0,0,0};
long fp2[10]= { 10000, 10000, 0,-10000,-10000,0,0,0,0,0};
//put data of the required segments in arrays.

i8092MF_CONTINUE_INTP(
cardNo, AXIS_X, AXIS_Y, 0, 1, sv, v, a, d, nType, cp1, cp2, fp1, fp2);
//execute the 2-axis continuous interpolation.
//The deceleration point will be calculated automatically.
//For this example, the final position of this motion will return to the starting
point.

```

6.3.4 2-Axis Ratio Motion

- **BYTE** `i8092MF_RATIO_INITIAL`(**BYTE** *cardNo*, **DWORD** *SV*, **DWORD** *V*, **DWORD** *A*, **float** *ratio*)

Description:

This function sets the Initial values for ratio motion (motion in ratio) using a symmetric T-curve speed profile. However, it is a software macro-function; therefore, it requires CPU resource to run this function.

Parameters:

<i>cardNo</i> :	Module number
<i>SV</i> :	Set the value for the starting speed (in PPS).
<i>V</i> :	Set the value for the vector speed (in PPS).
<i>A</i> :	Set the acceleration value (in PPS/Sec).
<i>ratio</i> :	Set the ratio value between the two assigned axes.

Return:

None

Example:

```
i8092MF_RATIO_INITIAL(...);  
//Initial setting for i8092MF_RATIO_2D(...) function.  
//Please refer to the example of i8092MF_RATIO_2D() function.
```

- **BYTE** i8092MF_RATIO_2D(**BYTE** cardNo, **WORD** nType, **long** data, **WORD** nDir)

Description:

This function performs a two-axis ratio motion.

Parameters:

<i>cardNo</i> :	Module number
<i>nType</i> :	0 → Perform the ratio motion. 1 → Declare the end of ratio motion.
<i>data</i> :	The pulse number of X-axis (-8,388,607 ~ +8,388,607)
<i>nDir</i> :	Direction of the Y-axis. 0: CW; 1: CCW

Return:

YES	An error has occurred. Use the i8092MF_GET_ERROR_CODE () function to identify the error.
NO	No errors.

Example:

```
BYTE cardNo=1; //select module 1.  
int sv=300; //set starting speed to 300 PPS.  
int v=18000; //set vector speed to 18000 PPS.  
long a=500000; //set acceleration value to 500K PPS/Sec.  
int loop1, loop2;  
i8092MF_SET_MAX_V(cardNo, 0xf,160000);  
//set maximum speed value to 18000 PPS.  
i8092MF_RATIO_INITIAL(cardNo, sv, v, a, 0.36);  
//The ratio is 0.36.  
for (loop2 = 0; loop2 < 5; loop2++)  
{  
    for (loop1 = 0; loop1 < 5; loop1++)  
    {  
        i8092MF_RATIO_2D(cardNo, 0, 3600, 0);  
    }  
}
```

```

        //perform the ratio motion in the CW direction.
        i8092MF_RATIO_2D(cardNo, 0, 3600, 1);
        //perform the ratio motion in the CCW direction.
    }
    i8092MF_RATIO_2D(cardNo, 0, 7200, 0);
    i8092MF_RATIO_2D(cardNo, 0, 3600, 1);
}
i8092MF_RATIO_2D(cardNo, 1, 7200, 0);
//End the ratio motion.

```

6.3.5 Mixed Linear and Circular 2-axis motions in Continuous Interpolation

- `void i8092MF_MIX_2D_INITIAL(BYTE cardNo, WORD nAcc, DWORD VSV, DWORD VV, DWORD VA)`

Description:

This function does the initial settings for mixed linear and circular 2-axis motions in continuous interpolation.

Parameters:

<i>cardNo</i> :	Module number
<i>nAcc</i> :	0 → constant speed (VV) 1 → symmetric T-curve Acc/Dec (VSV ∙ VV ∙ VA)
<i>VSV</i> :	Starting speed (in PPS)
<i>VV</i> :	Vector speed (in PPS)
<i>VA</i> :	Vector acceleration (PPS/Sec)

Return:

None

Example:

```

i8092MF_MIX_2D_INITIAL(...);
//This function should be defined before the i8092MF_MIX_2D_CONTINUE()
//function is used. Please refer to the example of this function.

```

- **BYTE** i8092MF_MIX_2D_CONTINUE(**BYTE** cardNo, **WORD** nAcc, **WORD** nType, **long** cp1, **long** cp2, **long** fp1, **long** fp2)

Description:

This function executes mixed linear and circular 2-axis motion in continuous interpolation. However, it is a software macro-function; therefore, it requires CPU resource to run this function.

Parameters:

cardNo: Module number
nAcc: 0 → continuous interpolation.
 1 → it is the last command of this continuous interpolation. In Acc/Dec mode, it will perform a deceleration stop. In constant speed mode, it will directly stop rather than decelerate.

nType:

1 → i8092MF_LINE_2D(**BYTE** cardNo, **long** fp1, **long** fp2);
 2 → i8092MF_ARC_CW(**BYTE** cardNo, **long** cp1, **long** cp2, **long** fp1, **long** fp2);
 3 → i8092MF_ARC_CCW(**BYTE** cardNo, **long** cp1, **long** cp2, **long** fp1, **long** fp2);
 4 → i8092MF_CIRCLE_CW(**BYTE** cardNo, **long** cp1, **long** cp2);
 5 → i8092MF_CIRCLE_CCW(**BYTE** cardNo, **long** cp1, **long** cp2);

cp1: It assigns the center point data at X-axis.
 (-8,388,607 ~ +8,388,607)

cp2: It assigns the center point data at Y-axis.
 (-8,388,607 ~ +8,388,607)

fp1: It assigns the end point data at X-axis.
 (-8,388,607 ~ +8,388,607)

fp2: It assigns the end point data at Y-axis.
 (-8,388,607 ~ +8,388,607)

Return:

YES An error has occurred. Use the i8092MF_GET_ERROR_CODE () function to identify the error.
NO No errors.

Example:

```

BYTE cardNo=1; //select module 1.
int sv=300; //starting speed: 300 PPS
int v=18000; //vector speed: 18000 PPS
long a=500000; //acceleration: 500000 PPS/Sec

unsigned short loop1;
i8092MF_SET_MAX_V(cardNo, AXIS_XY, 160000);
  
```



```
i8092MF_MIX_2D_INITIAL(cardNo, 1, sv, v, a);  
for (loop1 = 0; loop1 < 10000; loop1++)  
{  
    i8092MF_MIX_2D_CONTINUE (cardNo, 0, 1, 0, 0, 100, 100);  
    i8092MF_MIX_2D_CONTINUE (cardNo, 0, 2, 100, 0, 100, 100);  
}  
i8092MF_MIX_2D_CONTINUE (cardNo, 1, 4, 100, 100, 0, 0);
```

6.4 Set the Interrupt Factors

6.4.1 Set the Interrupt Factors

- `void i8092MF_INTFACTOR_ENABLE(BYTE cardNo, WORD axis, WORD nINT)`

Description:

This function sets the interrupt factors

Parameters:

cardNo: Module number

axis: Axis or axes (Please refer to Table 2-1)

nINT: Interrupt factors

Value	Symbol	Statement
1	P>=C-	Interrupt occurs when the value of logical / real position counter is larger than or equal to that of COMP- register. The COMP- must be pre-configured with <code>i8092MF_SET_COMPARE()</code> (please refer to Section 6.5.7)
2	P<C-	Interrupt occurs when the value of logical / real position counter is smaller than that of COMP- register. The COMP- must be pre-configured with <code>i8092MF_SET_COMPARE()</code> (please refer to Section 6.5.7)
3	P>=C+	Interrupt occurs when the value of logical / real position counter is smaller than that of COMP+ register. The COMP+ must be pre-configured with <code>i8092MF_SET_COMPARE()</code> (please refer to Section 6.5.7)
4	P<C+	Interrupt occurs when the value of logical / real position counter is larger than or equal to that of COMP+ register. The COMP+ must be pre-configured with <code>i8092MF_SET_COMPARE()</code> (please refer to Section 6.5.7)
5	C-END	Interrupt occurs at the end of the constant speed drive or completion of Acceleration Offset Pulse output.
6	C-STA	Interrupt occurs at the start of the constant speed drive or begin of Acceleration Offset Pulse output.
7	D-END	Interrupt occurs when the driving is finished

Return:

None

Example:

```
HANDLE hINT; //Interrupt event handle
HANDLE i8092_hThread; //IST handle
DWORD WINAPI i8092_ThreadFunction(LPVOID IPParam); //IST function
BYTE CardNo=1;
BYTE Slot1=1;

//MFC button event: Create the thread and set the interrupt factor
void Ci8092QCDlg::OnTestint()
{
    DWORD dwThreadId = 0;
    HWND hWnd = NULL;
    //Create thread: i8092_ThreadFunction
    i8092_hThread = CreateThread(NULL, 0, i8092_ThreadFunction, hWnd, 0,
    &dwThreadId);
    BYTE axis=AXIS_XY;
    i8092MF_SET_MAX_V(CardNo, axis, 20000);
    i8092MF_NORMAL_SPEED(CardNo, axis, 0);
    i8092MF_SET_V(CardNo, axis, 20000);
    i8092MF_SET_A(CardNo, axis, 100000);
    i8092MF_SET_SV(CardNo, axis, 20000);
    i8092MF_SET_AO(CardNo, axis, 0);
    //Initialize the interrupt
    hINTP=Slot_Register_Interrupt(Slot1);
    //Set the interrupt factor: D-END
    i8092MF_INTFACTOR_ENABLE(CardNo, AXIS_X, 7);
    // 4-Axis fixed pulse drive
    i8092MF_FIXED_MOVE(CardNo, AXIS_XY, 10000);

    while (i8092MF_STOP_WAIT(CardNo, 0xf) == NO)
    { //Wait for motion done
        DoEvents();
        Sleep(1);
    }
}

//IST function
DWORD WINAPI i8092_ThreadFunction(LPVOID IPParam)
{
    DWORD dwEvent;
    WORD RR3_X;
    if(hINTP != NULL)
    {
        //Wait the event object
        dwEvent = WaitForSingleObject(hINTP, INFINITE);
        switch(dwEvent)
        {
```

```

case WAIT_OBJECT_0:
    //Get the interrupt event object successfully
    //While the driving stop, clear the position counter
    i8092MF_SET_LP(CardNo, AXIS_X, 0)
    // ...
    //Other user codes in the IST
    // ...
    //End of the interrupt
    Slot_Interrupt_Done(Slot1);
    //Get the interrupt status
    RR3_X = i8092_GET_RR3(CardNo, AXIS_X);
    //Disable the interrupt factor
    i8092MF_INTFACTOR_DISABLE(CardNo, AXIS_X);
    //Close the interrupt
    Slot_Interrupt_Close(Slot1);
    break;
case WAIT_TIMEOUT:
    break;
case WAIT_FAILED:
    break;
}
}

return 1;
}

```

Note:

Please refer the three functions: Slot_Register_Interrupt(BYTE Slot), Slot_Interrupt_Done(BYTE Slot), Slot_Interrupt_Close(BYTE Slot) in the WinConSDK.

6.4.2 Interrupt Disabled

- **void** i8092MF_INTFACTOR_DISABLE(**BYTE** cardNo, **WORD** axis)

Description:

This function disables the interrupt factors

Parameters:

cardNo: Module number
axis: Axis or axes (Please refer to Table 2-1)

Return:

None

Example:

Please refer to 6.4.1

6.4.3 Read the Interrupt Occurrence

- **WORD** i8092MF_GET_RR3(**BYTE** cardNo, **WORD** axis)

Description:

Read the RR3 register that reflects the occurrence of Interrupt.

Parameters:

cardNo: Module number

axis: Axis or axes (Please refer to Table 2-1)

Return:

The content of RR3 register.

RR3 Value		説明
0x002	P>=C-	Once the value of logic / real position counter is larger than that of COMP- register
0x004	P<C-	Once the value of logic / real position counter is smaller than that of COMP- register
0x008	P<C+	Once the value of logic / real position counter is smaller than that of COMP+ register
0x010	P>=C+	Once the value of logic / real position counter is larger than that of COMP+ register
0x020	C-END	Interrupt occurs at the end of the constant speed drive or completion of Acceleration Offset Pulse output.
0x040	C-STA	Interrupt occurs at the start of the constant speed drive or begin of Acceleration Offset Pulse output.
0x080	D-END	Interrupt occurs when the driving is finished

Example:

```
i8092MF_GET_RR3 (cardNo, AXIS_X);  
//read the Interrupt status of AXIS_X
```

6.5 Other functions

6.5.1 Holding the Driving Command

- **void** i8092MF_DRV_HOLD(**BYTE** *cardNo*, **WORD** *axis*)

Description:

This command is usually used when users desire to start multi-axis driving simultaneously. When this command is issued, users may write other driving commands to the control card. All the driving commands will be held after i8092MF_DRV_HOLD() is issued, and these commands will be started once the i8092MF_DRV_START() is issued. However, if in driving, this command will not cause the driving to be stopped. But the next command will be held.

Parameters:

cardNo: Module number
axis: Axis or Axes (Please refer to Table 2-1 for the axis definition.)

Return:

None

Example:

Please refer to the example in section 6.5.2.

6.5.2 Release the Holding Status, and Start the Driving

- **void** i8092MF_DRV_START(**BYTE** *cardNo*, **WORD** *axis*)

Description:

This command releases the holding status, and start the driving of the assigned axes immediately.

Parameters:

cardNo: Module number
axis: Axis or Axes (Please refer to Table 2-1 for the axis definition.)

Return:

None

Example:

```
BYTE cardNo=1; //select card 1.
i8092MF_DRV_HOLD(cardNo, AXIS_XY); //hold the driving command to XY
i8092MF_SET_MAX_V(cardNo, AXIS_XY, 10000);
//set the maximum speed of X-axis and Y-axis to be 10K PPS.
i8092MF_NORMAL_SPEED(cardNo, AXIS_XY, 0);
//set the driving mode to be symmetric T-curve.
i8092MF_SET_V(cardNo, AXIS_X, 2000);
//set the speed of X-axis to 2,000 PPS.
i8092MF_SET_A(cardNo, AXIS_X, 1000);
//set the acceleration of X-axis to 1,000 PPS/S.
i8092MF_SET_SV(cardNo, AXIS_X, 2000);
//set the starting speed to 2,000 PPS.
i8092MF_SET_V(cardNo, AXIS_Y, 2000);
//set the speed of Y-axis to 2,000 PPS.
i8092MF_SET_A(cardNo, AXIS_Y, 1000);
//set the acceleration of Y-axis to 1,000 PPS/S.
i8092MF_SET_SV(cardNo, AXIS_Y, 2000);
//set the starting speed to 2,000 PPS.
i8092MF_FIXED_MOVE(cardNo, AXIS_X, 5000);
//command X-axis to move 5,000 Pulse. This command is be held.
i8092MF_FIXED_MOVE(cardNo, AXIS_Y, 15000);
//command Y-axis to move 15,000 Pulse. This command is be held.
i8092MF_DRV_START(cardNo, AXIS_XY);
//release the holding status. X and Y axes will start to move simultaneously.
```

6.5.3 Waiting until the Motion Is Completed

- **BYTE** i8092MF_STOP_WAIT(**BYTE** cardNo, **WORD** axis)

Description:

This function can be used to assign commands to be performed while waiting for all motion to be completed (stopped).

Parameters:

cardNo: Module number
axis: Axis or axes (Please refer to Table 2-1)

Return:

YES Motion is complete
NO Motion is not complete

EXAMPLE:

```
BYTE cardNo=1; //select module 1
i8092MF_SET_MAX_V(cardNo, AXIS_XY, 20000);
//set the maximum speed of all axes on module 1 to 20K PPS.
i8092MF_NORMAL_SPEED(cardNo, AXIS_XY, 0);
//set the speed profile of all axes on module 1 to be symmetric T-curve
i8092MF_SET_V(cardNo, AXIS_XY, 2000);
//set the speed of all axes on module 1 to 2000 PPS.
i8092MF_SET_A(cardNo, AXIS_XY,1000);
//set the acceleration value of all axes on module 1 to 1000 PPS/S.
i8092MF_SET_SV(cardNo, AXIS_XY, 2000);
//set the start velocity of all axes on module 1 to 2000 PPS.
i8092MF_SET_AO(cardNo, AXIS_XY, 9);
//set the value of remaining offset pulses to 9 pulses.
i8092MF_FIXED_MOVE(cardNo, AXIS_XY, 10000);
// move all axes on module 1 for 10000 pulses.

if (i8092MF_STOP_WAIT(cardNo, AXIS_X) == NO)
{
    //perform some actions here if the X axis has not finished its
    //motion.
}
```

6.5.4 Stopping the Axes

- `void i8092MF_STOP_SLOWLY(BYTE cardNo, WORD axis)`

Description:

This function decelerates and finally stops the assigned axes slowly.

Parameters:

cardNo: Module number
axis: Axis or axes (Please refer to Table 2-1)

Return:

None

Example:

```
i8092MF_STOP_SLOWLY(1, AXIS_XY);  
//decelerate and stop the X and Y axes
```

- `void i8092MF_STOP_SUDDENLY(BYTE cardNo, WORD axis)`

Description:

This function immediately stops the assigned axes.

Parameters:

cardNo: Module number
axis: Axis or axes (Please refer to Table 2-1)

Return:

None

Example:

```
i8092MF_STOP_SUDDENLY(1, AXIS_XY);  
//immediately stop the X and Y axes.
```

- **void** i8092MF_VSTOP_SLOWLY(**BYTE** cardNo)

Description:

This function stops interpolation motion of the assigned module in a decelerating way.

Parameters:

cardNo: Module number

Return:

None

Example:

```
i8092MF_VSTOP_SLOWLY(1);  
//stop the interpolation of card 1 in a decelerating way.
```

- **void** i8092MF_VSTOP_SUDDENLY(**BYTE** cardNo)

Description:

This function stops interpolation motion of the assigned module immediately.

Parameters:

cardNo: Module number

Return:

None

Example:

```
i8092MF_VSTOP_SUDDENLY(1);  
// stop the interpolation of card 1 immediately.
```

- **void** i8092MF_SSTOP_SLOWLY(**BYTE** *cardNo*, **WORD** *axis*)

Description:

Except for State-Control, This function provides the similar feature with i8092MF_STOP_SLOWLY (). Stop pulse output simply (**no ERROR_CODE 256 returned**).

Parameters:

cardNo: Module number
axis: Axis or axes (Please refer to Table 2-1)

Return:

None

Example:

```
i8092MF_SSTOP_SLOWLY(1, AXIS_XY);  
//decelerate and stop the X and Y axes
```

- **void** i8092MF_SSTOP_SUDDENLY(**BYTE** *cardNo*, **WORD** *axis*)

Description:

Except for State-Control, This function provides the similar feature with i8092MF_VSTOP_SUDDENLY (). Stop pulse output simply(**no ERROR_CODE 256 returned**).

Parameters:

cardNo: Module number
axis: Axis or axes (Please refer to Table 2-1)

Return:

None

Example:

```
i8092MF_SSTOP_SUDDENLY(1, AXIS_XY);  
//immediately stop the X and Y axes.
```

- **void** i8092MF_SVSTOP_SLOWLY(**BYTE** cardNo)

Description:

Except for State-Control, This function provides the similar feature with i8092MF_VSTOP_SLOWLY (). Stop pulse output simply(**no ERROR_CODE 256 returned**).

Parameters:

cardNo: Module number

Return:

None

Example:

```
i8092MF_SVSTOP_SLOWLY(1);  
//stop the interpolation of card 1 in a decelerating way.
```

- **void** i8092MF_SVSTOP_SUDDENLY(**BYTE** cardNo)

Description:

Except for State-Control, This function provides the similar feature with i8092MF_VSTOP_SUDDENLY (). Stop pulse output simply(**no ERROR_CODE 256 returned**).

Parameters:

cardNo: Module number

Return:

None

Example:

```
i8092MF_SVSTOP_SUDDENLY(1);  
// stop the interpolation of card 1 immediately.
```

6.5.5 Clear the Stop Status

- **void** i8092MF_CLEAR_STOP(**BYTE** *cardNo*)

Description:

After using anyone of the stop functions mentioned in section 6.5.4, please solve the malfunction, then issue this function to clear the stop status.

Parameters:

cardNo: Module number

Return:

None

Example:

```
i8092MF_CLEAR_STOP(1);  
//clear the error status of card 1.
```

6.5.6 End of Interpolation

- **void** i8092MF_INTP_END(**BYTE** *cardNo*, **WORD** *type*)

Description:

1. If the current motion status is running a interpolation motion and you would like to issue a single axis motion or change the coordinate definition, you should call this function before the new command is issued.
2. You can redefine the **MAX_V** for each axis. In this way, you do not have to execute i8092MF_INTP_END() function.

Parameters:

cardNo: Module number
type: 0 → 2-axis interpolation
 1 → 3-axis interpolation

Return:

None

Example:

```
i8092MF_INTP_END(1, 0); //declare the end of a 2-axis interpolation on card 1.
```

6.5.7 Setting the COMPARE value

- `void i8092MF_SET_COMPARE(BYTE cardNo, WORD axis, WORD nSELECT, WORD nTYPE, long data)`

Description:

This function sets the values of COMPARE registers. However, it will disable the functions of software limits.

Parameters:

<i>cardNo:</i>	Module number
<i>axis:</i>	Axis or axes (Please refer to Table 2-1)
<i>nSELECT:</i>	Select the COMPARE register 0 → COMP+ 1 → COPM-
<i>nTYPE:</i>	Select the source for comparison 0 → Position(P) = LP 1 → Position(P) = EP
<i>data:</i>	Set the COMPARE value: -2,147,483,648 ~ +2,147,483,647

Return:

None

Example:

```
i8092MF_SET_COMPARE(cardNo, AXIS_X, 0, 1, 5000);  
//Set the comparison function for X-Axis.  
//Set the compared source to be EP; and the COMP+ value to 5000.
```

Appendix A (I-8092F Basic Functions)

A.1 i8092F Command Set

Table A-1 I-8092F motion command classification

Function Classification	Statement
Registers Management Functions	Set the command register (WR0), mode registers (WR1~WR3), output register (WR4), and interpolation mode register (WR5). Get the status registers (RR0~RR7)
Initial Functions	Set the initial status of the system. There are about the registration, the card name, the slot number, the output pulse mode and hardware limit signal and software limit signal.
Basic Motion Command Functions	Provides the (T/S)-Curve acceleration/ deceleration (symmetric / asymmetric) for 2-axes.
Interpolation Functions	Provides the 2 axes linear interpolation, circular interpolation, and 2 axes bit pattern interpolation
Automatic Home Search	Provides the automatic home search function, the hardware signals setting, and the extension mode function setting.
Interrupt Control Functions	Uses the MCX312's interrupt factors and the interrupt service routine (ISR) to design the path planning or command the continuous motion.
Axis I/O Signal Functions	Include the alarm, In-position, external signal settings and the servo input status settings.
Register Management Functions	Include the set/get of the logic position counters and the encoder position counters, and get the current velocity and acceleration.

A.2 Pulse Output Command

A.2.1 Signal Types

I-8092F has two modes for pulse output command: One is fixed-pulse command output mode; the other is continuous pulse command output mode. User can choose the modes by setting the specific registers. There are two ways to choose the desired pulse mode: a) adjusting hardware jumper, and b) setting registers by software programming. The output pulse command modes are showing in Table 2-2. Moreover, the detail illustration for the pulse modes are shown in Fig. A-1~ Fig. A-6.

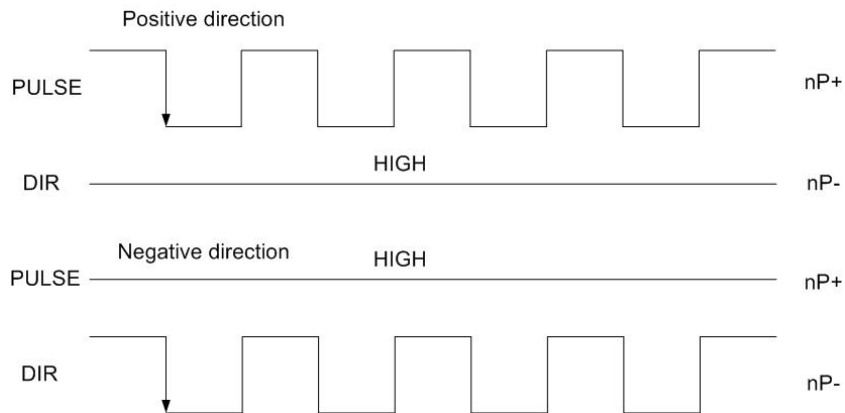

Fig. A-1 CW/CCW Input mode 1

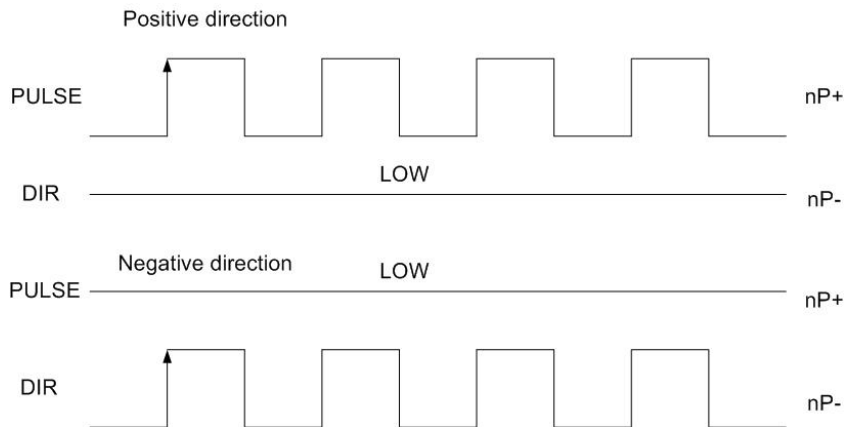

Fig. A-2 CW/CCW Input mode 2

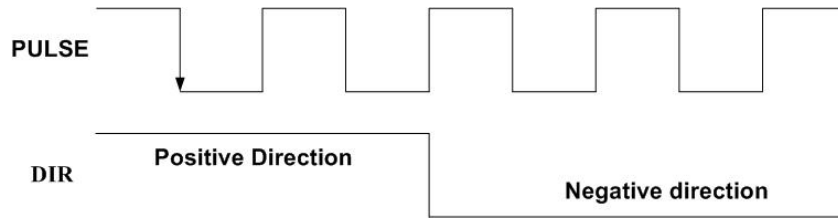

Fig. A-3 Pulse / Direction input mode 1

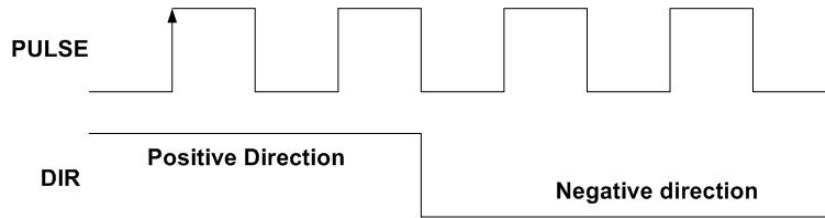

Fig. A-4 Pulse / Direction input mode 2

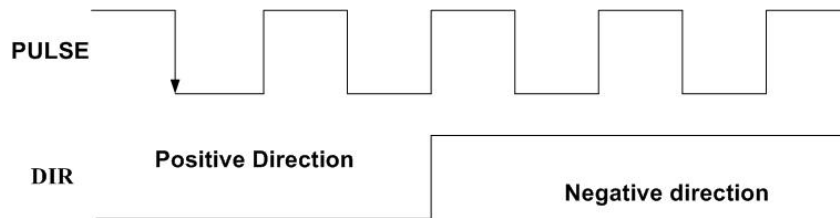

Fig. A-5 Pulse / Direction input mode 3

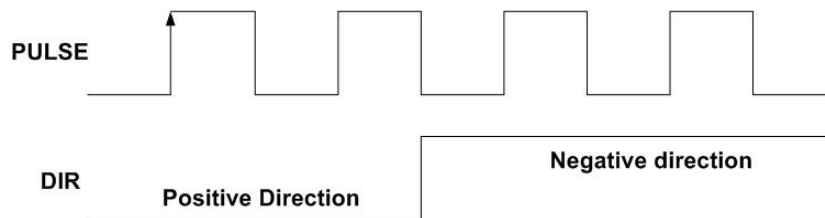

Fig. A-6 Pulse / Direction input mode 4

A.2.2 Fixed Pulse Driving

When host CPU writes a pulse numbers into I-8092F for fixed pulse driving, and configures the performance such as acceleration / deceleration and speed. I-8092F will generate the pulses and output them automatically. When output pulse numbers are equal to the command pulse numbers, I-8092F stops the output. The profile is showing in Fig. A-7. Concerning the execution of fixed pulse driving in acceleration / deceleration, it is necessary to set the following parameters:

- Range: R
- Initial Speed: SV (PPS)
- Driving Speed: V (PPS)
- Acceleration: A (PPS/Sec)
- Deceleration: D (PPS/Sec)
- Output Pulse Numbers: P

A.2.3 Changing Output Pulse Numbers in Driving

The output pulse numbers can be changed in the fixed pulse driving. If the command is for increasing the output pulse, the pulse output profile is shown as Fig. A-8 or A-9.

If the command is for decreasing the output pulses, the output pulse will be stopped immediately as shown in Fig. A-10. Furthermore, when in the S-curve acceleration /deceleration driving mode, the output pulse number change will occur to an incomplete deceleration S-curve.

A.2.4 Offset Setting for Acceleration/Deceleration Driving

The offset function can be used for compensating the pulses when the decelerating speed doesn't reach the setting initial speed during the S-curve fixed pulse driving. It will calculate the acceleration / deceleration point automatically, and will arrange the pulse numbers in acceleration equal to that in deceleration. The method is calculating the output acceleration pulses and comparing them with the remaining pulses. When the remaining pulses are equal to or less the pulses in acceleration, it starts the deceleration. When setting the offset for deceleration, it will start deceleration early for the offset. The remaining pulses of offset will be driving output at the initial speed (see Fig. A-11). The default value for offset is 8 when motion card power-on reset. It is not necessary to change the shift pulse value in the case of acceleration/deceleration fixed pulse driving.

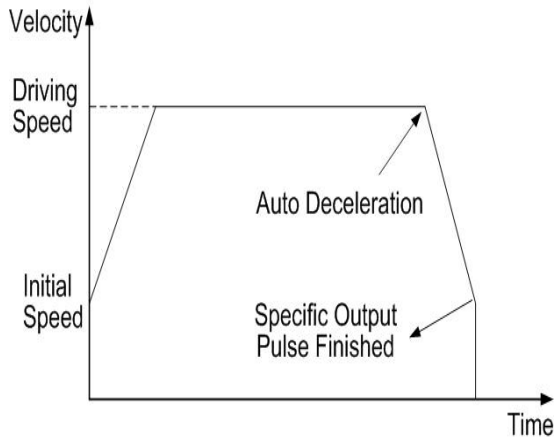

Fig. A-7 Fixed pulse driving

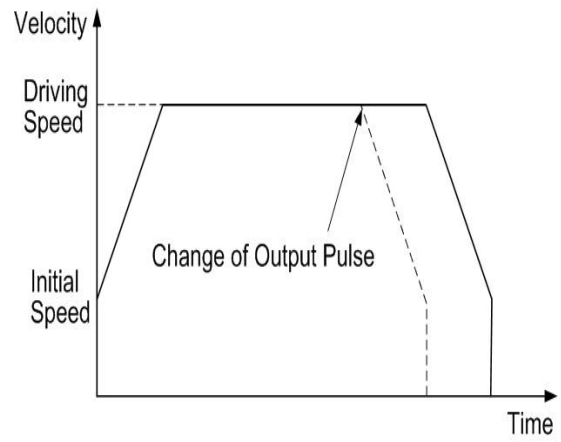

Fig. A-8 Changing the output pulse numbers in driving

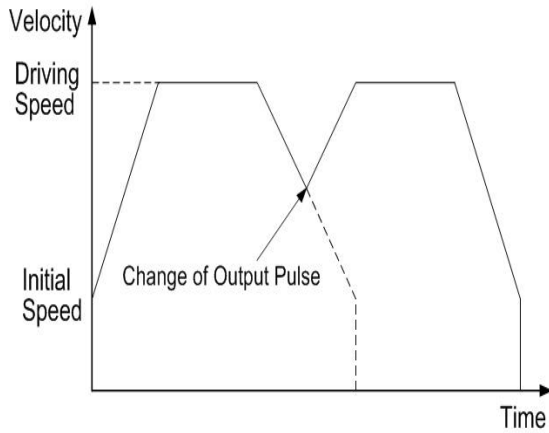

Fig. A-9 Changing command during deceleration

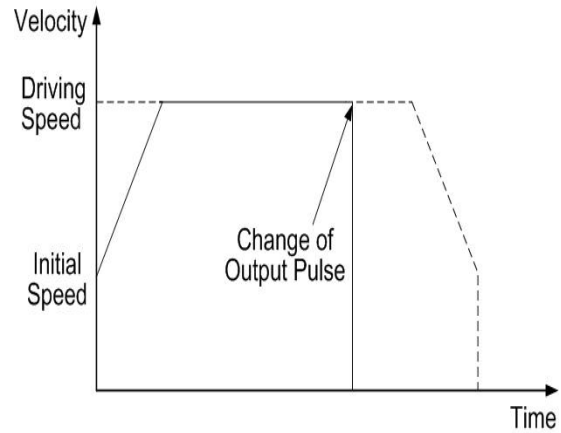

Fig. A-10 Changing the lesser pulse numbers than output pulse stop

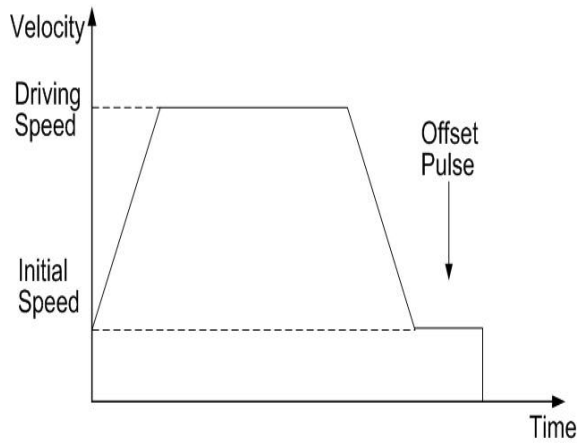

Fig. A-11 Offset pulse in fixed-pulse driving

A.2.5 Continuous Drive Pulse Output

When the continuous driving is performed, it will drive pulse output in a specific speed until stop command or external stop signal is happened. The main application of continuous driving is: home searching, teaching or speed control. Two stop commands are for stopping the continuous driving. One is “decelerating stop”, and the other is “sudden stop”. Four input pins, IN3~IN0, of each axis can be connected for external decelerating and sudden stop signals. Enable / disable, active levels and mode setting are possible. And it is necessary to set the following parameters:

- Range: R
- Initial Speed: SV (PPS)
- Driving Speed: V (PPS)
- Acceleration: A (PPS/Sec)

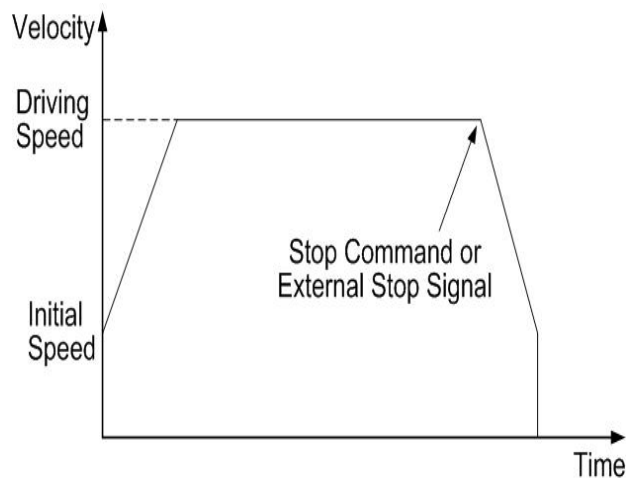

Fig. A-12 Continuous driving

A.2.6 Constant Speed Driving

When the driving speed command set in I-8092F is lower than the initial speed, the acceleration /deceleration will not be performed, instead, a constant speed driving starts. If the user wants to perform the sudden stop when the home sensor or encoder Z-phase signal is active, it is better not to perform the acceleration / deceleration driving, but the low-speed constant driving from the beginning. For processing constant speed driving, the following parameters will be preset accordingly.

- Range: R
- Initial Speed: SV
- Drive Speed: V (Just set one of SV and V can be attained the effect)
- Output Pulse Numbers: P (Only applicable for the fixed pulse driving)□

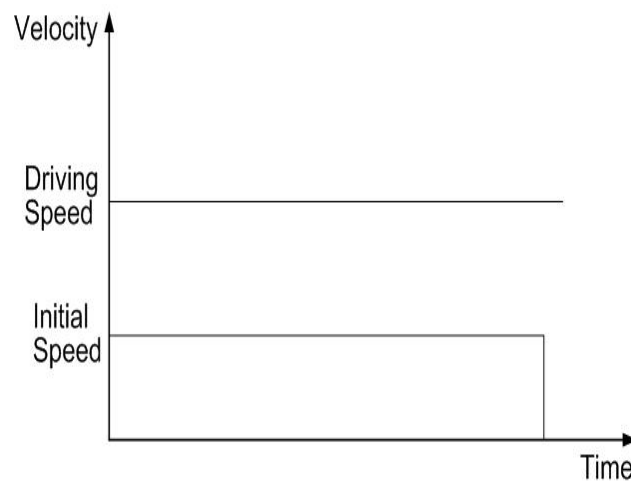

Fig. A-13 Constant speed driving

A.3 Profile Acceleration/Deceleration Planning

According to the motion control, we should use acceleration / deceleration planning for improving the capability of path planning and reducing the position error. The speed driving profile in I-8092F can be configured as T-curve and S-curve acceleration / deceleration.

A.3.1 Trapezoidal Driving [Symmetric]

- T-curve Description

The linear acceleration / deceleration driving is also called the trapezoidal driving. About the correlation parameters are: total displacement S , start speed SV , driving speed V , acceleration A . By above the parameters we can plan the trapezoidal driving:

Acceleration equation:

$$V = SV + A \times TA \quad (1-1)$$

The time for the end of constant speed:

$$TM = \frac{S}{V} \quad (1-2)$$

The time for the start of constant speed:

$$A = \frac{V - SV}{TA} \quad (1-3)$$

The T-Curve acceleration / deceleration planning are shown in Fig. A-14.

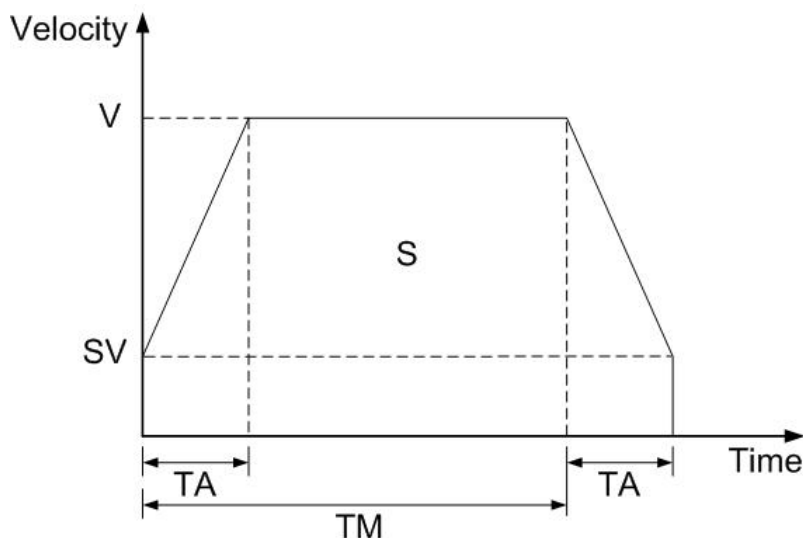

Fig. A -14 Symmetric T-curve acc./dec. planning

Trapezoidal driving is starting from the initial speed to the designated drive speed. The accelerating pulses will be counted, and the deceleration (automatic deceleration) starts from the

drive speed to initial speed once the remaining pulse numbers are less than the accelerating pulse numbers.

Usually, the user should set the same acceleration and deceleration rates. For some cases, the acceleration and deceleration can be set individually by setting the D1 of WR3 to 1. When the deceleration is set individually in fixed pulse driving, the automatic deceleration will not be performed, but the manual deceleration is required. The user should set the bit D1 of Register WR3 as 1, and then use decelerating command (03h) to set the deceleration.

When performing the symmetric trapezoidal driving, the following parameters should be preset.

- Range: R
- Initial Speed: SV (PPS)
- Driving Speed: V (PPS)
- Acceleration: A (PPS/Sec)
- Output Pulse Number P

A.3.2 Trapezoidal Driving [Asymmetric]

When an object is to be moved using stacking equipment, the acceleration and the deceleration of vertical transfer need to be changed since gravity acceleration is applied to the object. I-8092F performs automatic deceleration in fixed pulse driving in the non-symmetric linear acceleration where the acceleration and the deceleration are different. It is not necessary to set a manual deceleration point by calculation in advance. Fig. A-15 shows the case where the deceleration is greater than the acceleration and Fig. A-16 shows the case where the acceleration is greater than the deceleration. In such asymmetric linear acceleration also, the deceleration start point is calculated within the IC based on the number of output pulse P and each rate parameter.

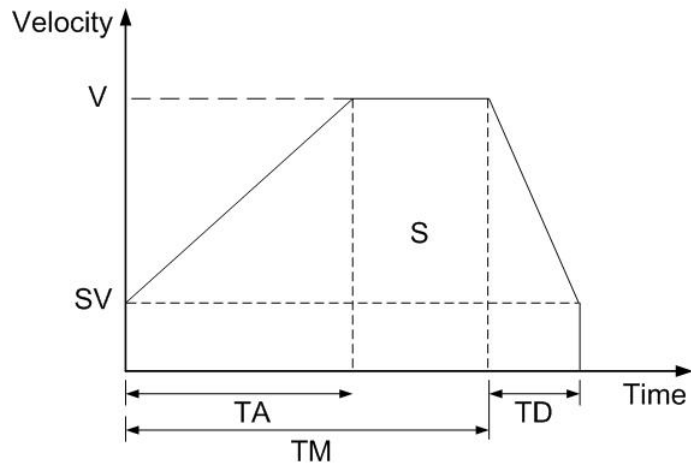

Fig. A-15 Asymmetric T-curve acc./dec. driving ($A < D$)

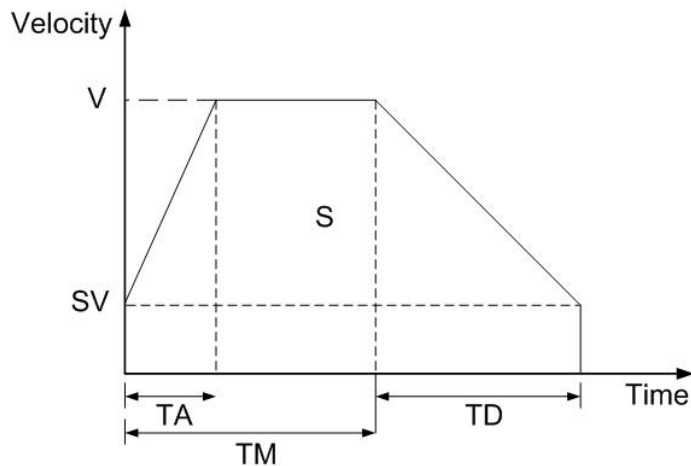

Fig. A-16 Asymmetric T-curve acc./dec. driving ($A > D$)

When performing the asymmetric trapezoidal driving, the following parameters should be set.

- Range: R
- Acceleration: A (PPS/Sec)
- Deceleration: D (PPS/Sec)
- Initial Speed : SV: (PPS)
- Driving Speed: V: (PPS)
- Output Pulse Number: P

Note: In the case of $A > D$, the following condition is applied to the ratio of the acceleration and the deceleration. $D > A \times \frac{V}{4 \times 10^6}$, where CLK=16 MHz

A.3.3 Triangle Prevention

The triangle prevention function prevents a triangle form in linear acceleration fixed pulse driving even if the number of output pulses is low. When the number of pulses that were utilized at acceleration and deceleration exceeds 1/2 of the total number of output pulses during acceleration, the IC (MCX312) stops acceleration and enters a constant speed mode. The triangle prevention function is disabled at resetting. And set the WR6/D3 (AVTRI) bit of the extension mode by setting command (60h) to 1 can enable the Function.

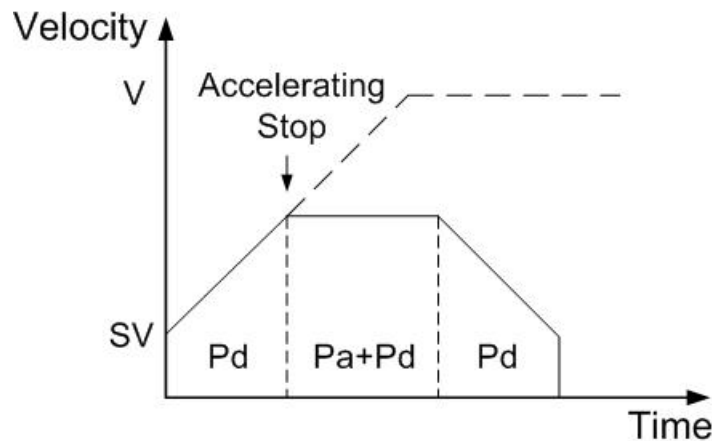

Fig. A-17 Triangle prevention of fixed pulse driving

$$P=2 \times (P_a+P_d)$$

P: Output pulse number

P_a : Number of pulses utilized at acceleration

P_d : Number of pulses utilized at deceleration

A.3.4 S-curve Acceleration / Deceleration [Symmetry]

- Complete S-curve Description

The complete S-Curve is composed of two two-degree velocity curves; if we set the time of the acceleration is TA :

Velocity equation of segment (1):

$$V(t) = Ct^2, \quad t < TA/2 \quad (1-4)$$

Velocity equation of segment (2):

$$V(t) = V - C(TA - t)^2, \quad t > TA/2 \quad (1-5)$$

Boundary condition:

$$V(0) = 0, \quad V(TA/2) = V/2, \quad V'(0) = 0 \quad (1-6)$$

By the BCs and then we can find that

$$C = \frac{2V}{(TA)^2} \quad (1-7)$$

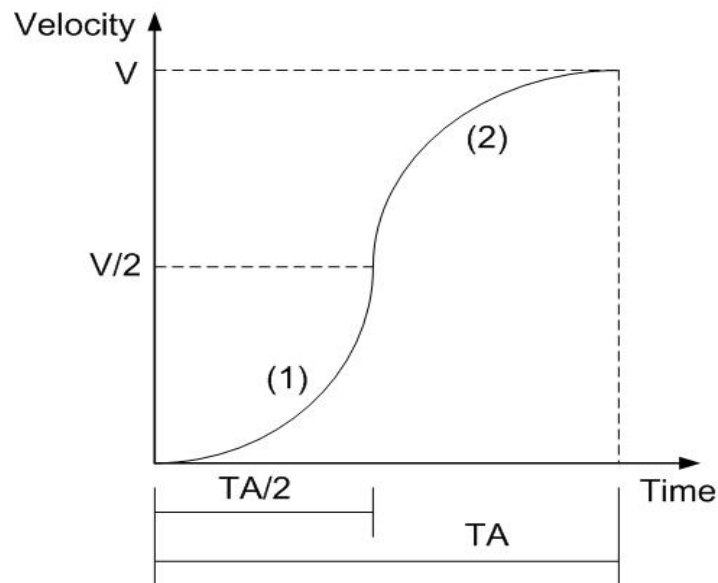

Fig. A-18 Complete S-curve acc. planning

● Partial S-curve Description

Partial S-curve is composed of three segments (1, 2, 3): one straight line and two S-curve lines. S-curve is the (1), (3) segments for S-curve acceleration, the straight line is (2) segment for linear acceleration; the total motion time is defined TA , and the time of the linear acceleration is $TA - (2 \times TS)$. However there is the same acceleration value in the join of the three segments.

Velocity equation of segment (1):

$$V(t) = C_1 t^2, \quad t < TS \quad (1-8)$$

Velocity equation of segment (2):

$$V(t) = C_2 t, \quad TS < t < TA - TS \quad (1-9)$$

Velocity equation of segment (3):

$$V(t) = V - C_1(TA - t)^2, \quad TA - TS < t < TA \quad (1-10)$$

The constant value C_2 is the slope of the line:

$$C_2 = \frac{V - 2VS}{TA - 2TS} \quad (1-11)$$

Boundary condition of the connection for (1), (2):

$$V'(TS) = C_2 \quad (1-12)$$

We can find that
$$C_1 = \frac{V}{2[TS^2 + (TS \times (TA - 2TS))]} \quad (1-13)$$

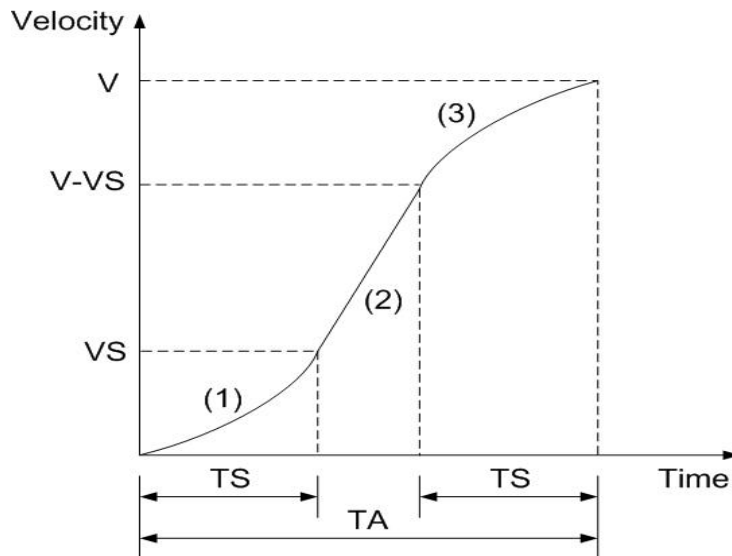

Fig. A-19 Partial S-curve planning

In case of S-curve acceleration / deceleration driving, the acceleration profile is not linear. The

value of acceleration / deceleration is shaped as the trapezoid; see Fig. A-20. In acceleration, there are three regions with different acceleration values. At the beginning, the acceleration increase linearly from 0 to the specific value A with a specific rate of acceleration K, this shows the driving speed increase parabolically in this region. Then, the driving speed increases in a constant acceleration in region b. And, in section c, the acceleration decelerates linearly to 0 with the rate of deceleration K. So the acceleration of S-curve includes regions a, b and c. In deceleration, as same as acceleration, the driving speed decelerate parabolically in three regions d, e and f.

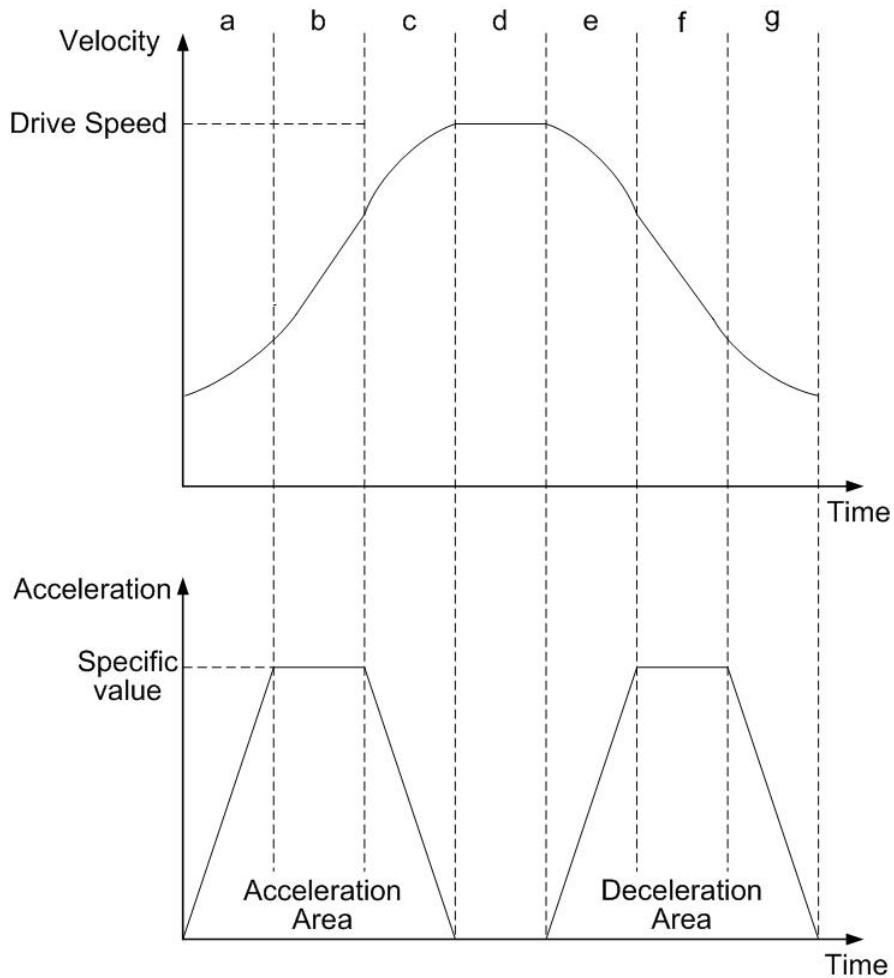

Fig. A-20 S-Curve acceleration / deceleration driving

When the fixed pulse trapezoidal driving is performed, and also when the deceleration is performed before the acceleration stops, the triangle driving profile is coming out. The prevention of triangle driving profile in S-curve acceleration / deceleration driving will be discussed as follows. If the initial speed is 0, and if the rate of acceleration is a , then the speed at time t in acceleration region can be described as following.

$$V(t) = Kt^2 \tag{1-14}$$

Therefore, the total output pulse number $p(t)$ from time 0 to t is the integrated of speed.

$$p(t) = \int V(t) dt = \frac{1}{3} Kt^3 \tag{1-15}$$

The total output pulse is

$$(1/3 + 2/3 + 1 + 2/3 + 1 + 1/3) \times at^3 = 4at^3 \tag{1-16}$$

From (1-15), (1-16), when the output pulse in acceleration of S-curve is more than 1/12 of total output pulse; it will stop increasing acceleration and start to decrease the acceleration value.

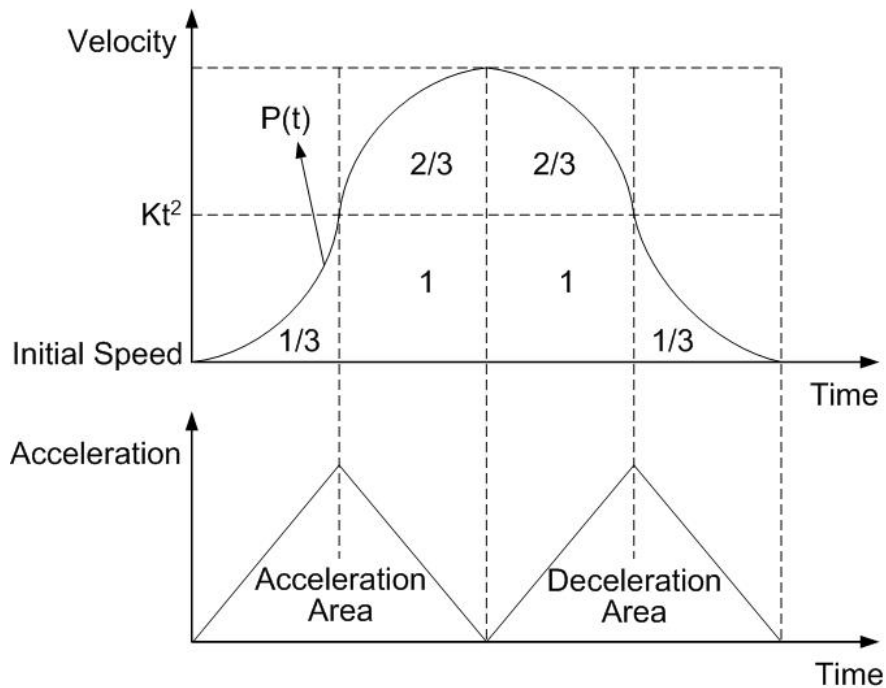

Fig. A-21 The rule of 1/12 of parabolic acceleration/deceleration.

A.4 Pulse Output Commands

A.4.1 2-Axes Interpolation

The I-8092F can be set for linear interpolation. To execute the linear interpolation, the user can, according to the present point coordinates, set the finish point coordinates and the interpolation command(s), as shows in Fig. A-22. For individual axis control, the command pulse number is unsigned, and it is controlled by + direction command or - direction command. For interpolation control, the command pulse number is signed. The resolution of linear interpolation is within ± 0.5 LSB. We define the longest distance movement in interpolation is the “long axis”. And the other is “short axis”. The long axis outputs an average pulse train. The driving pulse of the short axis depends on the long axis and the relationship of the two axes. The range for each axis is a 24-bit signed counter, from $-2^{23} \sim +2^{23}$.

When performing the linear interpolation, the following parameters should be preset.

- Range: R
- Initial Speed: SV (PPS)
- Driving Speed: V (PPS)
- Acceleration: A (PPS/Sec)
- Acceleration rate:K(PPS/Sec²)
- Manual decelerating Point DP
- Finish Position FP

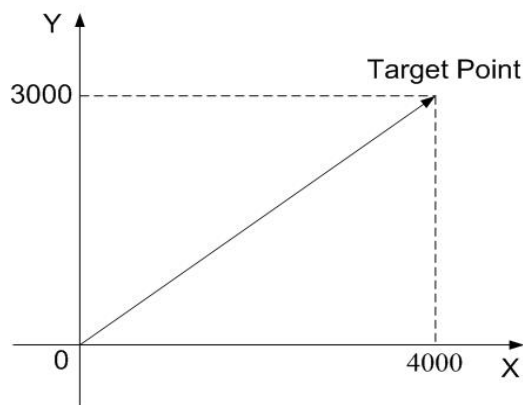

Fig. A-222 2-axes linear interpolation

A.4.2 Circular Interpolation

I-8092F can be selected for circular interpolation. The circular interpolation is starting from the current position (start point). After setting the center point of circular, the finish position and the CW or CCW direction, the user can start the circular interpolation. Note: The coordinates setting value is the relative value of the start point coordinates. In Fig. A-23, it explains the definition of CW and CCW circular interpolations. The CW circular interpolation is starting from the start point to the finish position with a clockwise direction; the CCW circular interpolation is with a counter-clockwise direction. When the finish point is set to (0, 0), a circle will come out.

When performing the circular linear interpolation, the following parameters should be preset.

- Range: R
- Initial Speed: SV (PPS)
- Driving Speed: V (PPS)
- Acceleration: A (PPS/Sec)
- Finish Position FP
- Manual decelerating Point DP
- Circular Center Position C

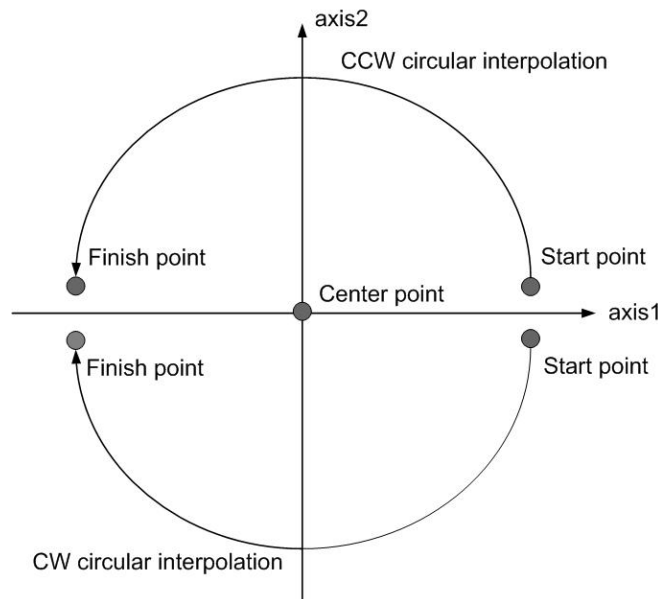

Fig. A-233 Circular interpolation

In Fig. A.24, it explains the long axis and the short axis. First, we define 8 quadrants in the X-Y plane and put the numbers 0~7 to each quadrant. We find the absolute value of ax1 is always larger than that of ax2 in quadrants 0, 3, 4 and 7, so we call ax1 is the long axis (ax2 is the short axis) in these quadrants; in quadrants 1, 2, 5 and 6, ax2 is the long axis (ax1 is the short axis). The short axis will output pulses regularly, and the long axis will output pulses depending on the interpolation calculation.

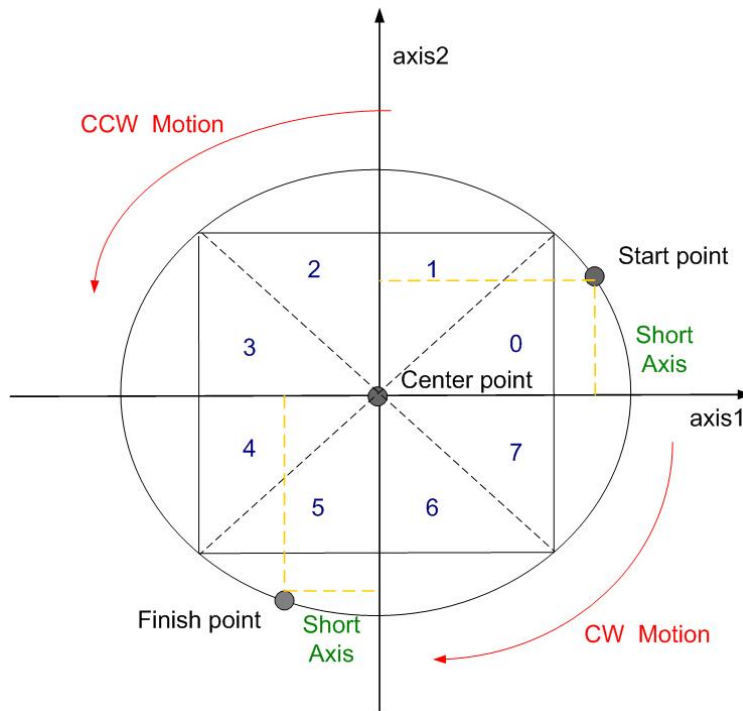

Fig. A-24 The 0~7Quadrants in circular interpolation calculation

► **Note:** The calculation steps for the manual deceleration length of circular interpolation

1. First judge the start point and finish point located on which quadrant
2. Calculate the pulse number of the start point and finish point on the quadrant.
(Take notice of the different motion direction (CW/CCW)).
3. Calculate the whole quadrant numbers that passed through in the path planning.
4. The result of step3+step4 is the total pulse number.
5. Users can get the suitable multiple from the setting maximum speed, if the multiple = M, and then the real start speed: $RSV = SV \times M$, real driving speed: $RV = V \times M$, real acceleration: $RA = A \times 125 \times M$
- By the equation: $RSV = RV + RA \times TA$, and you can get the time and displacement for the acceleration area.
6. If the pulse numbers of deceleration segment are same as the acceleration segment, it can figure easily:

manual decelerating point = total output pulse – output pulse during acceleration

Fig. A-25 shows the circular interpolation of a real circle with radius 10000 in a trapezoidal driving. The user should calculate the decelerating point before driving because the automatic deceleration will not be active. In the figure, the circle tracks through all the 8 quadrants: 0~7. In quadrant 0, Y axis is the short axis and its displacement is about $10000 / 2 = 7071$

The total output pulses numbers of the short axis are $7010 \times 8 = 56568$. Furthermore, if the initial speed is 500PPS, and will be accelerated to 20KPPS after 0.3 SEC, the acceleration will be $(20000 - 500) / 0.3 = 65000 \text{PPS/SEC}$. And the output pulses during acceleration will be $(500 + 20000) \times 0.3 / 2 = 3075$. Thus, if we set the deceleration as same as the acceleration, the manual decelerating point will be $56568 - 3075 = 53493$.

► **Note:** 1. This formula cannot be used in the constant vector speed driving.
 2. In circular interpolation only manual deceleration in trapezoidal driving is available; the automatic deceleration in S-curve driving is not available.

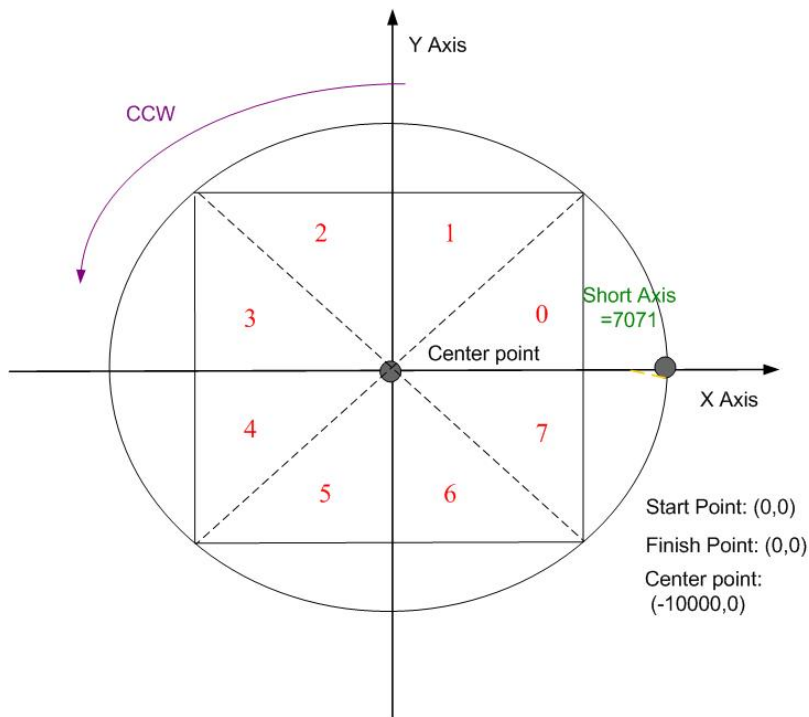

Fig. A-25 Calculation of manual deceleration point for circular interpolation

A.4.3 Bit Pattern Interpolation

This interpolation driving receives interpolation data that is created by upper-level CPU and transformed to bit patterns in a block of a predetermined size, and outputs interpolation pulses consecutively at the specified drive speed. Every axis has 2 bit-data buffers for host CPU: one for + direction and the other for - direction. When performing the bit pattern interpolation, the host CPU will write the designated interpolation data, for 2 or 3 axes, into I-8092F. If a bit in the bit pattern data from CPU is "1", I-8092F will output a pulse at the time unit; if it is "0", I-8092F will not output any pulse at the time unit. For example, if the user want to generate the X-Y profile (see Fig. A-27), the host CPU must write a set of pattern into those specific registers --- XPP: the + direction register for X axis, XPM: the - direction register for X axis, YPP and YPM: the + and - directions registers. With in the time unit, I-8092F will check the registers once and decide to output a pulse or not depending on the bit pattern.

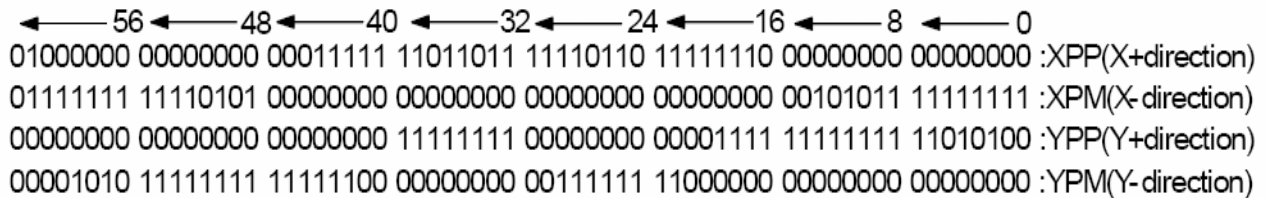

Fig. A-26 Bit pattern data for X-Y profile

Stacking counter (SC) is a 2-bit counter. Its value is between 0 and 3, which can be read from D14, 13 of register RR0. SC will decide which register for the data from the host CPU. The initial value of SC is 0. So, when host CPU writes bit pattern data into BP1P or BP1M, the data will be stored in SREG, and then, SC will count up to 1, and the next data from the host CPU will be written into REG1. By this way, the REG2 becomes the register when SC=2. The host CPU is not able to write any bit pattern data into MCX312 when SC=3.

When the bit pattern interpolation pulse is outputting, D0 in SREG (Stack Register) will be shifted output first, and then in the order of D1, D....When all of SREGs (Stack Registers) have been shifted output, the data in REG1 will be shifted to SREG, the data in REG2 will be shifted to REG1, and the SC will count down to 2. Then, the host CPU is able to write a new data into MCX312 again.

In order to make MCX312 output the bit pattern data continuously, the host CPU should write the data into MCX312 before SC counts down to 0. MCX312 will output an interrupt requirement signal to host CPU when SC counts down from 2 to 1.

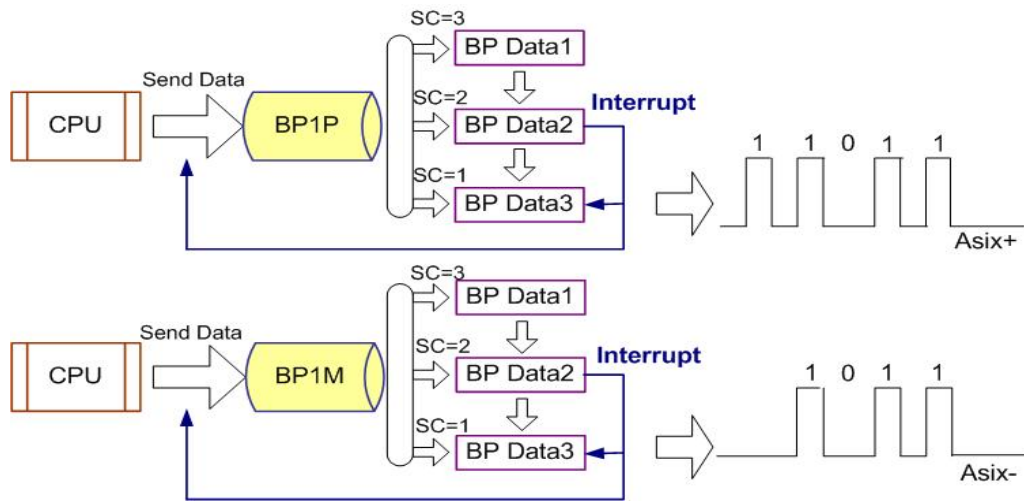

Fig. A-27 Bit pattern data stack

■ The limitation for the speed of bit pattern interpolation driving

The maximum pulse output speed is 4MHz in bit pattern interpolation mode. However, the maximum speed will depend on the data update rate of host CPU if the bit pattern data are more than 48bits. For example of the X and Y axes bit pattern interpolation, if the host CPU needs 100μsec to update new 16-bit data for X and Y axes. The maximum speed is $16/100\mu\text{SEC}=160\text{KPPS}$.

■ The ending of bit pattern interpolation

There are 2 ways can terminate the bit pattern interpolation.

(1) Write an ending code into buffer register of ax1. The bit pattern interpolation mode will be finished, and stopped if the host CPU write "1" into both + and - directions buffer registers. When the ending code is executed, the SC will become 0 automatically.

(2)The host CPU stops writing any command into I-8092F.

When SC=0, and when no other data is updated, I-8092F will stop outputting pulse. Then, the bit pattern interpolation is finished.

■ Utilizing the stop command to pause the interpolation

The interpolation driving will be paused if a sudden stop or decelerating stop command is written into the master axis (ax1) which is executing the bit pattern interpolation. I-8092F will continue the bit pattern interpolation if the host CPU enables the bit pattern interpolation again. If the host CPU wants to finish the interpolation after writing stop command, all of the interpolation bit data in the buffer must be cleared in using BP register

A.4.4 Continuous Interpolation

The continuous interpolation is executing a series of interpolation processes such as linear interpolation_n + circular interpolation_n + linear interpolation ... During the continuous interpolation, the driving will not stop contrarily, The pulses are output continuously. When executing the continuous interpolation, the host CPU has to write the next interpolation command into MCX312 before the previous interpolation command is finished.

■ Polling

If D9 (CNEXT) of register RR0 is 1, MCX312 is ready to accept the next interpolation command. If D9 is 0, the host CPU is not able to write the next interpolation command into MCX312. The D9 will become 1 only when the present command is executed. MCX312 will not accept the next command, and the D9 is 0 if the present command has not been executed. So, the standard procedure of continuous interpolation is first to write, and enable the interpolation data and command, then check if D9 of RR0 is 1 or 0. And then, repeat writing commands and checking D9. The flow chart is shown at the right side.

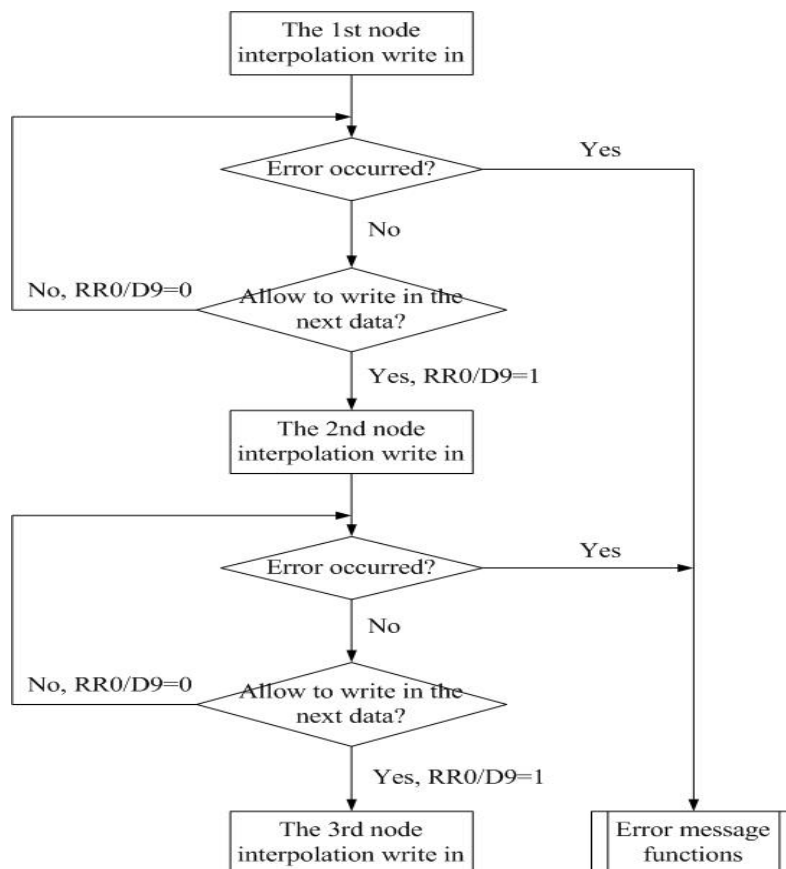

Fig. A-28 Continuous Interpolation by Polling Method

■ **Interrupt**

D14 of register WR5 is used for enable or disable the interrupt during the continuous interpolation. After setting D14 of register WR5 to 1, the interrupt occurs. Pin INTN of MCX314As will be on the Low level to interrupt the host CPU when D9 of register RR0 become 1. The INTN will be on the Hi level if the host CPU writes the next interpolation command to I-8092F. If the interrupt clear command (3Dh) is written to command register, the INTN signal will return to high-Z level from the Low level.

A.5 Automatic Home Search

Home search is often used when the machine was first opened or the system was occurred the alarm or error signal. Both of two above situations, user can take the home search motion to let the machine return the operation origin.

I-8092F provide the functions that automatically executes a home search sequence such as high-speed near home search → low-speed home search → encoder Z-phase search → offset driving without CPU intervention. Users should dispose the hardware signals as the same as the below figure. The figure shown below illustrates the example of 1-axis driving system. 2 axes can be assigned in the same way.

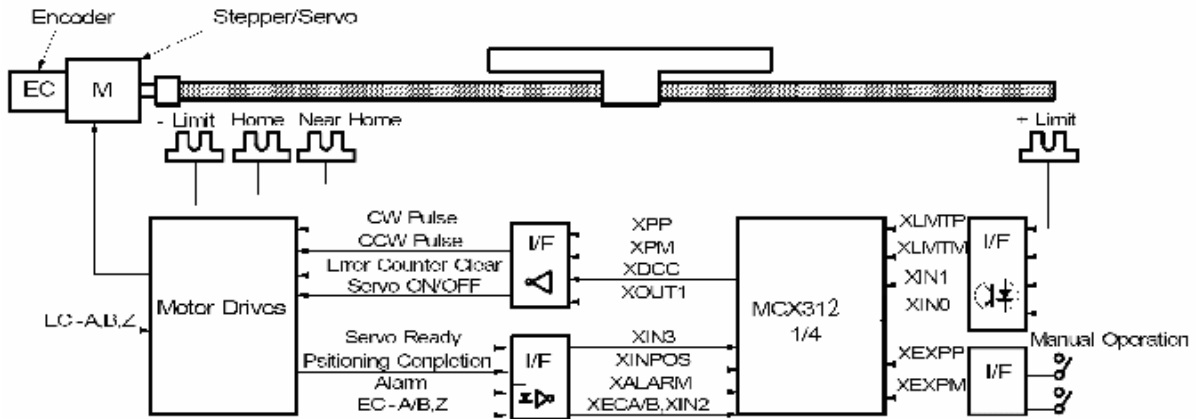

Fig. A-29 X-axis hardware signal disposition

A.6 Interrupt Control

A.6.1 Interrupt for Independent axis

A.6.2 Interrupt for Interpolation

A.7 I-8092F Function Library

We develop the simple but powerful high-level functions set application programming interface (API) by using the specific command and data registers of MCX312. These libraries are composed of motion and interpolation commands, status display, and I/O signal management make programming your controller easy. Finally, all setup and motion control functions are easily executed by calling into either a static or dynamic link library (DLL).

The development procedure of the software library is written by eVC (eMbedded Visual C++). After that, we use eVC to recompile the library become DLL (Dynamic Link Library), and use MFC (Microsoft Foundation Class) to develop the HMI (Human Machine Interface) for motion control. With inclusion of DLL and HMI, our package has the advantage that users do not need to design complicated path planning and code function driver to control the multi-axes motor. Finally, the capability and validity of the functions are tested by experiment in a 2-axis machine.

Each function will be displayed in following format:

i8092_FUNCTION_NAME(cardNo, axis, parameter1, parameter2)

where **cardNo** is the module number of i8092; **axis** can be one axis or two axes. Users can refer to Table 2-1 for more information.

WR0 Register

D15	D14~D12	D11	D10	D9	D8	D7~D0
RESET				Y	X	

Axis	X	Y	XY
Code	0x1	0x2	0x3
Name	AXIS_X	AXIS_Y	AXIS_XY

A.7.1 Register management functions

The definition of the WRn, RRn registers are detail shown in appendix B.

Table A-3 Register management functions

Function Name	Description
i8092_SET_COMMAND	The command register (WR0) for 2-axes setting
i8092_SET_WR1	The mode register (WR1) for 2-axes setting
i8092_SET_WR2	The mode register (WR2) for 2-axes setting
i8092_SET_WR3	The mode register (WR3) for 2-axes setting
i8092_GET_WR4	The output register (WR4) setting
i8092_SET_WR5	The interpolation register (WR5) setting
i8092_GET_RR0	The main status register (RR0) getting
i8092_GET_RR1	The status register 1 (RR1) getting
i8092_GET_RR2	The status register 2 (RR2) getting
i8092_GET_RR3	The status register 3 (RR3) getting
i8092_GET_RR4	The input register (RR4) getting
i8092_GET_RR5	The input register (RR5) getting

i8092_COMMAND

Format:

```
void i8092_COMMAND(unsigned char cardNo, WORD axis, WORD cmd)
```

Function:

Setting the command register (WR0) for 2-axes.

Parameters:

cardNo is the board number.

axis is the motion axes, as shown in Table2-1.

cmd is the command code setting in the WR0 register. Available command codes are shown in section A.8.

Example: //Set all axes for axis switching.

```
i8092_COMMAND(1, 0x3, 0xf);
```

i8092_SET_WR1

Format:

void i8092_SET_WR1(**unsigned char** cardNo, **WORD** axis, **WORD** data)

Function:

Set the mode register (WR1) for 2-axes.

Parameters:

cardNo is the board number.

axis is the motion axes, as shows in Table2-1.

data is the 32-bit hexadecimal value setting in the WR1 register.

Example: //Set the X axis's IN0 signal enabled and Hi active.

```
i8092_SET_WR1(1, 0x1, 0x0003);
```

i8092_SET_WR2

Format:

void i8092_SET_WR2(**unsigned char** cardNo, **WORD** axis, **WORD** data)

Function:

Set the mode register (WR2) for 2-axes.

Parameters:

cardNo is the board number.

data is the 32-bit hexadecimal value setting in the WR3 register.

Example: //Set the all axes software limit enabled as comparing with the real position counter.

```
i8092_SET_WR2(1, 0xf, 0x0023);
```

i8092_SET_WR3

Format:

void i8092_SET_WR3(**unsigned char** cardNo, **WORD** axis, **WORD** data)

Function:

Set the mode register (WR1) for 2-axes.

Parameters:

cardNo is the board number.

axis is the motion axes, as shows in Table 2-1.

data is the 32-bit hexadecimal value setting in the WR3 register.

Example: //Set the non-symmetry S-curve mode for x, y axes.

```
i8092_SET_WR3(1, 0x7, 0x0007);
```

i8092_SET_WR4

Format:

void i8092_SET_WR4(**unsigned char** cardNo, **WORD** data)

Function:

Setting the mode register (WR1) for 2-axes.

Parameters:

cardNo is the board number.

axis is the motion axes, as shows in Table 2-1.

data is the 32-bit hexadecimal value setting in the WR4 register.

Example: //Set the 2-axes OUT1 signals of Hi active level.

```
i8092_SET_WR4(1, 0xf, 0x0202);
```

i8092_SET_WR5

Format:

void i8092_SET_WR5(**unsigned char** cardNo, **WORD** data)

Function:

Set the interpolation register (WR5).

Parameters:

cardNo is the board number.

axis is the motion axes, as shows in Table 2-1.

data is the 32-bit hexadecimal value setting in the WR5 register.

Example: //Set the x, y axes of constant vector speed mode.

```
i8092_SET_WR5(1, 0xf, 0x0300);
```

i8092_GET_RR0

Format:

void i8092_GET_RR0(**unsigned char** cardNo, **WORD** axis)

Function:

Get the main status register (RR0).

Parameters:

cardNo is the board number.

axis is the motion axes, as shows in Table 2-1.

Example: //Get the x axis main status register.

```
i8092_GET_RR0(1, 0x1);
```

i8092_GET_RR1

Format:

void i8092_GET_RR1(unsigned char cardNo, WORD axis)

Function:

Get the main status register (RR1).

Parameters:

cardNo is the board number.

axis is the motion axes, as shows in Table 2-1.

Example: //Get the x axis status register 1.

```
i8092_GET_RR1(1, 0x1);
```

i8092_GET_RR2

Format:

void i8092_GET_RR2(unsigned char cardNo, WORD axis)

Function:

Get the main status register (RR2).

Parameters:

cardNo is the board number.

axis is the motion axes, as shows in Table 2-1.

Example: //Get the x axis status register 2.

```
i8092_GET_RR2(1, 0x1);
```

i8092_GET_RR3

Format:

```
void i8092_GET_RR3(unsigned char cardNo, WORD axis)
```

Function:

Get the main status register (RR3).

Parameters:

cardNo is the board number.

axis is the motion axes, as shows in Table 2-1.

Example: //Get the x axis main status register.

```
i8092_GET_RR0(1, 0x1);
```

i8092_GET_RR4

Format:

```
void i8092_GET_RR4(unsigned char cardNo)
```

Function:

Get the input register (RR4).

Parameters:

cardNo is the board number.

Example: //Get the input register 4.

```
i8092_GET_RR4(1);
```

i8092_GET_RR5

Format:

void i8092_GET_RR5(**unsigned char** cardNo, **WORD** data)

Function:

Get the input register (RR5).

Parameters:

cardNo is the board number.

Example: //Get the input register 5.

```
i8092_GET_RR5(1);
```

A.7.2 Functions for Initial Setting

We define some constant and structure for I8092 in i8092.h file.

Define card number and slot number

```
#define CARD1          1
#define CARD2          2
#define MAX_SLOT_NO    8
```

Define constant of decision

```
#define YES            1
#define NO             0
#define ON             1
#define OFF            0
#define SERVO_ON_flag 1
#define SERVO_OFF_flag 0
```

Define movement mode

```
#define ACCMODE       0
#define CONST2        1
#define CONST3        3
```

Interrupt factor

```
#define D_END          0x8000
#define C_STA          0x4000
#define C_END          0x2000
#define CP_GE          0x1000
#define CP_L           0x0800
#define CM_L           0x0400
#define CM_GE          0x0200
#define CI_INT         0x4001
#define BP_INT         0x8001
#define IDLE           0x0000
```

Transfer data type

```
#define BYTE           unsigned char
#define WORD           unsigned short int
#define DWORD          unsigned long int
```

Command buffer

```
#define wr0            0x0
#define wr1            0x2
#define wr2            0x4
#define wr3            0x6
#define wr4            0x8
#define wr5            0xa
#define wr6            0xc
#define wr7            0xe
```

Status buffer

#define	rr0	0x0
#define	rr1	0x2
#define	rr2	0x4
#define	rr3	0x6
#define	rr4	0x8
#define	rr5	0xa
#define	rr6	0xc
#define	rr7	0xe

Define Axis

#define	AXIS_X	0x1
#define	AXIS_Y	0x2
#define	AXIS_XY	0x3

Define drive mode

#define	PFD	0x20
#define	NFD	0x21
#define	PCD	0x22
#define	NCD	0x23

Table0-2 Function for Initial Setting

Function Name	Description
i8092_PULSE_MODE	Setting the output Pulse mode
i8092_SET_R	Setting the parameter determining the multiple of drive speed, acceleration / deceleration and jerk.
i8092_GET_R	Getting the global variable
i8092_HLMTP_LEVEL	Setting the Active Level of the HLMTP sensor
i8092_HLMTM_LEVEL	Setting the Active Level of the HLMTM sensor
i8092_SLMTM_MODE	Setting the mode of the SLMTM
i8092_SLMTM_MODE	Setting the mode of the SLMTM
i8092_COMPARE_LP	Setting the COMP+/- registers value and logic position
i8092_COMPARE_EP	Setting the COMP+/- registers value and Encoder position
i8092_RESET_CARD	Resetting the motion card

I8092_PULSE_MODE

Format:

void i8092_PULSE_MODE(unsigned char cardNo, WORD axis, WORD nMode)

Function:

The function can set the output pulse modes and explain in Sec 1.1.

Parameters:

cardNo is the board number.

axis is the motion axis code/name, as shows in Table 2-1.

nMode is the value 0~3, as shows in the following table.

Mode	Value	Direction	Waveform of input pulse	
			nPP / PULSE	nPM / DIR
CW / CCW	0	+	PULSE	LOW
	1	-	LOW	PULSE
PULSE / DIR	2	+	PULSE+	LOW
	3	-	PULSE+	HIGH
	4	+	PULSE-	LOW
	5	-	PULSE	HIGH

Example: //It sets that choosing all axes with CW/CCW (Dir.+) mode.

```
i8092_SET_PULSE_MODE(1, 0xf, 2);
```

i8092_SET_R

Format:

void i8092_SET_R(unsigned char cardNo, WORD axis, DWORD data)

Function:

"R" means "Range", is the parameter determining the multiple of drive speed, acceleration / deceleration and jerk. The calculation of the multiple is shown in the following formula:

Parameters:

cardNo is the board number.

axis is the motion axis code/name, as shows in Table 2-1.

Example: i8092_SET_R(1, 0xf, 8000000);

► **Note:** If the maximum value of parameter for setting the drive speed (V) is 8000, and the drive speed is set 40KPPS. The user can set V=8000 and R=1600000. Because 40K is 5 times of 8000, we set the R=8000000/5=1600000.

i8092_GET_R

Format:

DWORD i8092_GET_R(**unsigned char** cardNo, **WORD** axis)

Function:

Get the range value from the global variable.

Parameters:

cardNo is the board number.

axis is the motion axis code/name, as shows in Table 2-1.

Example: //Get the range value.

```
i8092_GET_R(1, 0x1);
```

i8092_HLMTP_LEVEL

i8092_HLMTM_LEVEL

Format:

void i8092_HLMTP_LEVEL(**unsigned char** cardNo, **WORD** axis, **WORD** nLevel)
void i8092_HLMTM_LEVEL(**unsigned char** cardNo, **WORD** axis, **WORD** nLevel)

Function:

Set the logical level of +/- direction hardware limit input signal.

Parameters:

cardNo is the board number.

axis is the motion axis code, as shows in Table 2-1.

nLevel is the active level, nLevel=0: Low active, nLevel =1: Hi active.

Other values are invalid.

Example: //Set the positive direction hardware limit as Low active for 2-axes.

```
i8092_HLMTP(1, 0xf, 0);
```

i8092_SLMTP_MODE i8092_SLMTM_MODE

Format:

```
void i8092_SLMTP_MODE(unsigned char cardNo, WORD axis, WORD nMode)
void i8092_SLMTM_MODE(unsigned char cardNo, WORD axis, WORD nMode)
```

Function:

Set the +/- direction software limit.

Parameters:

cardNo is the board number.

axis is the motion axis code/name, as shows in Table 2-1.

nMode n=0: Enable; n=1: Disable

Example: //Enable the positive direction software limit for 2 axes.

```
i8092_SLMTP_LEVEL(1, 0x3, 0);
```

i8092_COMPARE_LP

Format:

```
void i8092_COMPARE_LP (unsigned char cardNo, WORD axis)
```

Function:

The function selects the logical position counter (LP) as the comparing target of COMP+/- registers.

Parameters:

cardNo is the board number.

axis is the motion axis code, as shows in Table 2-1,

Example: //Set the comparing target to LP for all axes.

```
i8092_COMPARE_LP(1, 0x3);
```

i8092_COMPARE_EP

Format:

void i8092_COMPARE_EP (**unsigned char** cardNo, **WORD** axis)

Function:

The function selects the real position counter (EP) as the comparing target of COMP+/- registers.

Parameters:

cardNo is the board number.

axis is the motion axis code, as shows in Table 2-1,

Example: //Set the comparing target to EP for all axes.

```
i8092_COMPARE_EP(1, 0x3);
```

i8092_RESET_CARD

Format:

void i8092_RESET_CARD(**void**)

Function:

Command for resetting the motion card.

Parameter:

None.

Example: //Set the reset command.

```
i8092_RESET_CARD();
```

▶ **Note:** When the bit (WR0/D15) is set to 1, but others are 0, the IC will be reset after command writing.

A.7.3 Motion Status Management Functions

The logic position counter is counting the driving pulses in MCX312. When one + direction plus is outputting, the counter will count up 1; When one - direction pulse is outputting, the counter will count-down 1. The real position counter will count input pulse numbers from external encoder. The type of input pulse can be either A/B quadrature pulse type or Up / Down pulse(CW/CCW) type (See Chapter 2.6.3). Host CPU can read or write these two counters any time. The counters are signed 32 bits, and the counting range is between $-2^{31} \sim +2^{31}$.

Table A-4 Motion Status Management Functions

Function Name	Description
i8092_SET_LP	The logic position counter setting
i8092_SET_EP	The Real position counter setting
i8092_GET_LP	The logic position counter setting
i8092_GET_EP	Read the Real position counter
i8092_GET_CV	Read the current driving speed
i8092_GET_CA	Read the current acceleration / deceleration
i8092_SET_CP	Setting the positive direction software limit
i8092_SET_CM	Setting the negative direction software limit
i8092_VRING_ENABLE	Setting the position counter variable ring
i8092_VRING_DISABLE	Disable the position counter variable ring
i8092_AVTRI_ENABLE	Setting Triangle prevention of fixed pulse driving
i8092_AVTRI_DISABLE	Disable Triangle prevention of fixed pulse driving

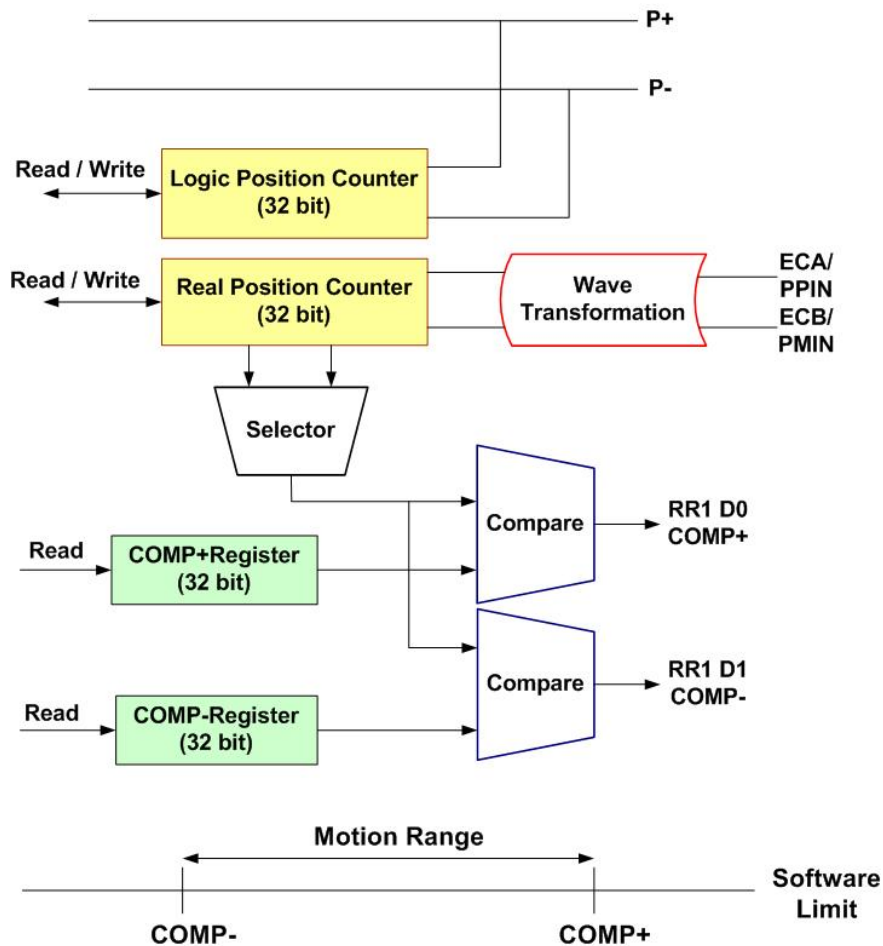

Fig. A-29 Management for Position Register and Software Limit

i8092_SET_LP

Format:

```
void i8092_SET_LP(unsigned char CardNo, WORD axis, long dwdata)
```

Function:

Set the logic position counter, it can be set zero to reset the counter values.

Parameters:

cardNo is the board number.

axis is the motion axis code, as shows in Table 2-1, only set for single axis.

dwdata: input value for logic position counter. Data range: $-2^{31} \sim +2^{31}$.

Example: //Clear the logic position counter value.

```
i8092_SET_LP(1, 0x1, 0);
```

```
i8092_SET_LP(1, 0x2, 0)
```

i8092_SET_EP

Format:

void i8092_SET_EP(unsigned char CardNo, WORD axis, long dwdata)

Function:

Set the logic position counter, it can be set zero to reset the counter values.

Parameters:

cardNo is the board number.

axis is the motion axis code, as shows in Table 2-1, only set for single axis.

dwdata: input value for real position counter, Data range: $-2^{31}\sim+2^{31}$.

Example: //Clear the logic position counter value.

```
i8092_SET_EP(1, 0x1, 0); i8092_SET_EP(1, 0x2, 0);
```

long i8092_GET_LP

Format:

long i8092_GET_LP(unsigned char CardNo, WORD axis)

Function:

The function can read the current value of logic position counter, and it will be set in read registers RR6 and RR7.

Parameters:

cardNo is the board number.

axis is the motion axis code, as shows in Table 2-1, only set for single axis.

Example: //Read the logic position counter for the X, Y axes.

```
i8092_GET_LP(1, 0x1); i8092_GET_LP(1, 0x2);
```

i8092_GET_EP

Format:

long i8092_GET_EP(**unsigned char** CardNo, **WORD** axis)

Function:

The function can read the current value of real position counter and it will be set in read registers RR6 and RR7.

Parameters:

cardNo is the board number.

axis is the motion axis code, as shows in Table 2-1, only set for single axis.

Example: //Read the real position counter for the X, Y axes.

```
i8092_GET_EP(1, 0x1);    i8092_GET_EP(1, 0x2);
```

i8092_GET_CV

Format:

WORD i8092_GET_CV(**unsigned char** CardNo, **WORD** axis)

Function:

The function can read the current drive speed, and it will be set in read registers RR6 and RR7. When the driving stops, the value becomes 0. The date value will increase from the setting value of start speed (SV) to the setting value of drive speed (V).

Parameters:

cardNo is the board number.

axis is the motion axis code, as shows in Table 2-1, only set for single axis.

Example: //Read the current velocity for the X, Y axes.

```
i8092_GET_CV(1, 0x1);
```

```
i8092_GET_CV(1, 0x2);
```

i8092_GET_CA

Format:

WORD i8092_GET_CA(**unsigned char** CardNo, **WORD** axis)

Function:

The function can read the current drive acceleration will be set in read registers RR6 and RR7. When the driving stops, the value becomes 0. The data value will increase from zero to the setting value of drive acceleration (A).

Parameters:

cardNo is the board number.

axis is the motion axis code, as shows in Table 2-1, only set for single axis.

Example: //Read the current acceleration for the X, Y axes.

```
i8092_READ_CA(1, 0x1);
```

```
i8092_READ_CA(1, 0x2);
```

i8092_SET_CP i8092_SET_CM

Format:

void i8092_SET_CP(**unsigned char** CardNo, **WORD** axis, **long** dwdata)
void i8092_SET_CM(**unsigned char** CardNo, **WORD** axis, **long** dwdata)

Function:

Set the COMP+/- registers value to be the positive direction software limit.

Parameters:

cardNo is the board number.

axis is the motion axis code/name, as shows in Table 2-1,

dwdata is the COMP+ register value. Data range: $-2^{31} \sim +2^{31}$.

Example: //Set the positive direction software limit to be 100000 for the X, Y axes.

```
i8092_SET_COMPP(1, 0x3, 100000);
```

```
//Set the positive direction software limit to be 100000 for the X, Y axes.
```

```
i8092_SET_COMP(1, 0x3, 100000);
```

i8092_VRING_ENABLE i8092_VRING_DISABLE

Format:

```
void i8092_VRING_ENABLE(unsigned char cardNo, WORD axis,  
                        DWORD nVRing)  
void i8092_VRING_DISABLE(unsigned char cardNo, WORD axis)
```

Function:

Enable/disable the setting of any value as the maximum value. This function is useful for managing the position of the axis in circular motions that return to the home position after one rotation, rather than linear motions.

Parameter:

cardNo is the board number.

axis is the motion axis code/name, as shows in Table 2-1,

nVRing is the value of the COMP+/COMP- registers. Data range: $-2^{31} \sim +2^{31}$.

Example: //For instance, set as follows for a rotation axis that rotates one cycle with
//10000 pulses. To enable the position variable ring function, And set 9999 in
//the COMP+/- registers as the maximum value of the logical position counter.
i8092_VRING_ENABLE(1, 0xf, 1, 9999);

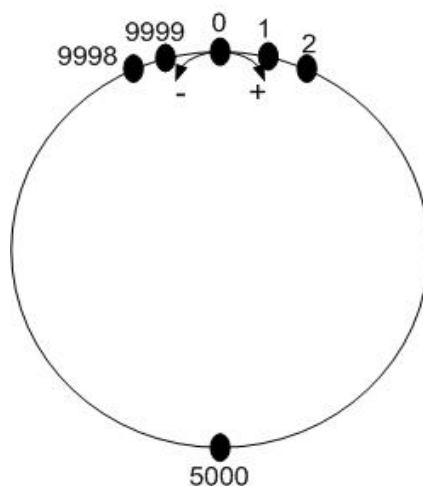

Fig. A-30 Operation of position counter ring maximum value 9999

- ▶ **Note:** 1. The variable ring function enable/disable is set for each axis, however, a logical position counter and a real position counter cannot be enabled/disables individually.
- 2. If a variable ring function is enabled, a software limit function cannot be used.

i8092_AVTRI_ENABLE

Format: `void i8092_AVTRI_ENABLE(BYTE cardNo, WORD axis)`

Function:

This function prevents a triangle form in linear acceleration (T-curve) fixed pulse driving even if the number of output pulses is low.

Parameters:

cardNo is the board number.

axis is the motion axis code/name, as shows in Table 2-1,

Example:

```
i8092_AVTRI_ENABLE(1, AXIS_X);  
//set the X axis of module 1 not to generate a triangle form in its speed profile.
```

i8092_AVTRI_DISABLE

Format: `void i8092_AVTRI_DISABLE(BYTE cardNo, WORD axis)`

Function:

This function disable the function that prevents a triangle form in linear acceleration (T-curve) fixed pulse driving even if the number of output pulses is low.

Parameters:

cardNo is the board number.

axis is the motion axis code/name, as shows in Table 2-1,

Example:

```
i8092_AVTRI_DISABLE(1, AXIS_X);  
//enable the X axis of module 1 to generate a triangle form in its  
//speed profile if the pulse number for output is too low.
```

A.7.4 Basic Motion Command Functions

The basic motion commands of I-8092F are listed in Table A-5. They are including the setting for range (R), multiple (M), start speed (SV), driving speed (V), acceleration (A), deceleration (D), acceleration rate (K), output pulse (P), T-Curve acceleration / deceleration, and S-Curve acceleration / deceleration. The whole command procedures should be set with the initial command registers. After setting correlation parameters, the CPU sends command or data through MCX312; finally, command enters in the logic-position-counter, and then sends to the driver to control the motor.

Table A-5 Basic Motion Command Functions

Function Name	Description
i8092_SET_SV	Initial speed setting
i8092_SET_V	Drive speed setting
i8092_SET_A	Acceleration setting
i8092_SET_D	Deceleration setting
i8092_SET_K	Acceleration rate setting
i8092_SET_L	Deceleration rate setting
i8092_SET_PULSE	Set output pulse number
i8092_SET_AO	Acceleration Counter Offsetting
i8092_SET_TCURVE	T-Curve acc./dec. mode enabled
i8092_SET_SCURVE	S-Curve acc./dec. mode enabled
i8092_SET_AUTODEC	Auto deceleration setting
i8092_SET_MANDEC	Manual deceleration setting
i8092_DRV_FDRIVE	Fixed pulse drive mode setting
i8092_DRV_CDRIVE	Continuous drive mode setting
i8092_SET_SYMMETRY	Symmetric T/S-curve Acc/Dec setting
i8092_SET_ASYMMETRY	Asymmetric T/S-curve Acc/Dec setting
i8092_STOP_WAIT	Drive and wait for stopping
i8092_STOP_SLOWLY	Slow-down stop
i8092_STOP_SUDDENLY	Emergent stop
i8092_DRV_HOLD	Holding for later driving
i8092_DRV_START	Drive holding release (starting motion)

i8092_SET_SV

Format:

void i8092_SET_SV(unsigned cardNo, **WORD** axis, **WORD** data)

Function:

This function can set the start speed. If the stop type is slow-down stop, the motion curve will be decelerating to the start speed and then stop. Set the start speed is SV, the multiple is M, and then the driving start is:

$$\text{Driving start speed(PPS)} = \text{SV} \times \text{M}$$

Parameters:

cardNo is the board number.

axis is the motion axis code/name, as shows in Table 2-1.

data is the value of SV, data range is 1~8000, other values are invalid.

Example: //Set the start velocity 500 (PPS) for X axis.

```
i8092_SET_SV(1, 0x1, 500);
```

i8092_SET_V

Format:

void i8092_SET_V(unsigned char cardNo, **WORD** axis, **WORD** data)

Function:

The function is setting the speed of constant speed period in trapezoidal driving. In constant speed driving, the drive speed is the initial speed. The drive speed calculation is shown in the following formula:

$$\text{Driving Speed(PPS)} = \text{V} \times \text{M}$$

Parameters:

cardNo is the board number.

axis is the motion axis code, as shows in Table 2-1.

data is value of acceleration, the range is 1~8000, other values are invalid.

Example: //Set the driving velocity 1000 (PPS) for X axis.

```
i8092_SET_V(1, 0x1, 1000);
```

► **Note:** 1. If the setting drive speed is lower than the initial speed, the acceleration / deceleration will not be performed, and the driving is constant speed. During the encoder Z-phase searching (at a low-speed driving), the user want to perform the sudden stop once the Z-phase is detected, the drive speed should be set lower than the initial speed. Drive speed can be altered during the driving. When the drive speed of next constant speed period is set, the acceleration / deceleration will be performed to reach the new setting drive speed, then a constant speed driving starts.

► **Note:** 2. In fixed pulse S-curve acceleration / deceleration driving, there is no way to change the drive speed during the driving. In continuous S-curve acceleration / deceleration driving, the S-curve profile cannot be exactly tracked if the speed alterations during the acceleration/deceleration. It is better to change the drive speed in the constant speed period.

i8092_SET_A

Format:

void i8092_SET_A(unsigned char cardNo, WORD axis, WORD data)

Function:

The function is setting the acceleration or deceleration of the trapezoidal driving. For S-curve acceleration / deceleration, it shows the linear acceleration until a specific value (A) driving. The acceleration calculation is shown in the following formula:

Driving Acceleration(PPS/Sec) = A×125×M

Parameters:

cardNo is the board number.

axis is the motion axes code/name, as shows in Table 2-1.

data is value of acceleration, it's range is 1~8000, other values are invalid.

Example: //Set the acceleration 80 (PPS/Sec) for X axis.

```
i8092_SET_A(1, 0x1, 80);
```

i8092_SET_D

Format:

void i8092_SET_D(unsigned char cardNo, WORD axis, WORD data)

Function:

The function use when acceleration/deceleration is set individually, “D” is the parameter determining the deceleration of the trapezoidal driving. For S-curve acceleration / deceleration, the designated deceleration can be set until a specific value (D) is driving. The deceleration calculation is shown in the following formula:

$$\text{Driving Deceleration(PPS/Sec)} = D \times 125 \times M$$

Parameters:

cardNo is the board number.

axis is the motion axis code/name, as shows in Table 2-1.

data is the value of deceleration, it's range is 1~8000, other values are invalid.

Example: //Set the deceleration 80 (PPS/Sec) for X axis.

```
i8092_SET_D(1, 0x1, 80);
```

i8092_SET_K

Format:

void i8092_SET_K(int cardNo, WORD axis, WORD data)

Function:

The function is setting the value of acceleraton rate (jerk), in a time unit, of S-curve Acc/Dec motion. The jerk calculation is shown in the following formula:

$$\text{Jerk (PPS/Sec}^2) = (62.5 \times 10^6 / K) \times M$$

Parameters:

cardNo is the board number.

axis is the motion axis code/name, as shows in Table 2-1.

data is the value of the acceleration rate, it's range is 1~65535.

Example: //Set the jerk 625 (PPS/Sec²) for the X axis.

```
i8092_SET_K(1, 0x1, 625);
```

► **Note:** For K=65535 to 1

When Multiple = 1, 954 PPS/SEC² ~ 62.5 x 10⁶ PPS/SEC²

When Multiple = 500, 477 x 10³ PPS/SEC² ~ 31.25 10⁹ PPS/SEC²

*In this manual, jerk is defined the increasing / decreasing rate of acceleration / deceleration in a time unit. However, jerk should cover the decreasing rate of acceleration and increasing rate of acceleration.

i8092_SET_L

Format:

void i8092_SET_L(int cardNo, **WORD** axis, **WORD** data)

Function:

The function is setting the deceleration rate (jerk), in a time unit, of S-curve Acc/Dec motion. The jerk calculation is shown in the following formula:

$$\text{Jerk (PPS/Sec}^2\text{)} = (62.5 \times 10^6 / K) \times M$$

Parameters:

cardNo is the board number.

axis is the motion axis code/name, as shows in Table 2-1.

data is the value of the acceleration rate, it's range is 1~65535.

Example: //Set the jerk 625 (PPS/Sec²) for the X axis.

```
i8092_SET_L(1, 0x1, 625);
```

► **Note:** For K=65535 to 1

When Multiple = 1, 954 PPS/SEC2 ~ 62.5 x 106 PPS/SEC2

When Multiple = 500, 477 x 103 PPS/SEC2 ~ 31.25 109 PPS/SEC2

i8092_SET_PULSE

Format:

void i8092_SET_PULSE(unsigned char cardNo, **WORD** axis, **DWORD** data)

Function:

The function is setting total output pulse numbers in fixed pulse driving. The value is absolute, unsigned number. The output pulse numbers can be changed during the driving.

Parameters:

cardNo is the board number.

axis is the motion axis code/name, as shows in Table 2-1.

data is the value of the pulse, it's range is 0~268435455, other values are invalid.

Example: //Set the driving pulse number (final point) 10000 for the X axis.

```
i8092_SET_PULSE(1, 0x1, 10000);
```

i8092_SET_AO

Format:

void i8092_SET_AO(unsigned char cardNo, WORD axis, WORD data)

Function:

The function is executing the acceleration counter offset. It is often used while the machine is using stepping motor. It can avoid the overshoot for high speed deceleration.

Parameters:

cardNo is the board number.

axis is the motion axis code/name, as shows in Table 2-1.

data is the value of the deceleration, it's range is 0~65535. Other values are invalid.

Example:

```
i8092_SET_AO(1, 0x1, 200);
```

i8092_SET_AUTODEC

Format:

void i8092_SET_AUTODEC(unsigned char cardNo, WORD axis)

Function:

Automatic deceleration setting.

Parameters:

cardNo is the board number.

axis is the motion axis code/name, as shows in Table 2-1.

Example://Enable the automatic deceleration for 2-axes.

```
i8092_SET_AUTODEC(1, 0xf);
```

► **Note:** The function is useless in circular interpolation for T-curve deceleration.

i8092_SET_MANDEC

Format:

`void i8092_SET_MANDEC(unsigned char cardNo, WORD axis, WORD dp)`

Function:

Set the manual deceleration point in fixed pulse acceleration/deceleration driving or interpolation motion when the manual deceleration mode is engaged. In manual deceleration mode, the user can set the bit D0 of WR3 register to 1.

The decelerating point calculates as :

Manual Decelerating Point = Output Pulse Numbers - Pulse Number for Deceleration

Parameters:

cardNo is the board number.

axis is the motion axis code/name, as shows in Table 2-1.

Example: //Set the manual deceleration point 8000 for the XY axes motion.

```
i8092_SET_MANDEC(1, 0x3, 8000);
```

- **Note:** The suitable time for setting manual deceleration point
1. Asymmetry S-curve acceleration/deceleration
 2. Circular interpolation

i8092_DRV_FDRIVE

Format:

`void i8092_DRV_FDRIVE(unsigned char cardNo, WORD axis, WORD nDir)`

Function:

Set fixed-pulse drive.

Parameters:

cardNo is the board number.

axis is the motion axis code/name, as shows in Table 2-1.

nDir is the direction of the motion. nDir = 0, positive; nDir = 1, negative

Example: //Set the negative fixed pulse drive.

```
i8092_DRV_FDRIVE(1, 0x3, 1);
```

i8092_DRV_CDRIVE

Format:

void i8092_DRV_CDRIVE(unsigned char cardNo, WORD axis, WORD nDir)

Function:

Set continuous drive.

Parameters:

cardNo is the board number.

axis is the motion axis code/name, as shows in Table 2-1.

nDir is the direction of the motion. nDir = 0, positive; nDir = 1, negative

Example: //Set the positive continuous drive.

```
i8092_DRV_CDRIVE(1, 0x3, 0 );
```

i8092_SET_SYMMETRY

Format:

void i8092_SET_SYMMETRY(unsigned char cardNo, WORD axis)

Function:

Set symmetry acceleration/deceleration.

Parameters:

cardNo is the board number.

axis is the motion axis code/name, as shows in Table 2-1.

Example: //Set the symmetry acc./dec. motion for 2-axes.

```
i8092_SET_SYMMETRY(1, 0xf);
```

i8092_SET_ASYMMETRY

Format:

void i8092_SET_ASYMMETRY(unsigned char cardNo, WORD axis)

Function:

Set asymmetry acceleration/deceleration

Parameters:

cardNo is the board number.

axis is the motion axis code/name, as shows in Table 2-1.

Example: //Set the asymmetry acc./dec. motion for 2-axes.

```
i8092_SET_ASYMMETRY(1, 0xf);
```

i8092_STOP_SLOWLY

Format:

void i8092_STOP_SLOWLY(**unsigned char** cardNo, **WORD** axis)

Function:

Motion command for stopping slowly.

Parameters:

cardNo is the board number.

axis is the motion axis code/name, as shows in Table 2-1.

Example: //Stop slowly command for 2-axes.

```
i8092_STOP_SLOWLY(1, 0xf);
```

i8092_STOP_SUDDENLY

Format:

void i8092_STOP_SUDDENLY(**unsigned char** cardNo, **WORD** axis)

Function:

Motion command for stopping suddenly.

Parameters:

cardNo is the board number.

axis is the motion axis code/name, as shows in Table 2-1.

Example: //Stop suddenly command for 2-axes.

```
i8092_STOP_SUDDENLY(1, 0xf);
```

i8092_DRV_HOLD

Format:

void i8092_DRV_HOLD(**unsigned char** cardNo, **WORD** axis)

Function:

Set holding for drive starting.

Parameters:

cardNo is the board number.

axis is the motion axis code/name, as shows in Table 2-1.

Example:

```
i8092_DRV_HOLD(1, 0xf);
```

i8092_DRV_START

Format:

```
void i8092_DRV_START(unsigned char cardNo, WORD axis)
```

Function:

Drive status holding release/finishing status clearing setting.

Parameters:

cardNo is the board number.

axis is the motion axis code/name, as shows in Table 2-1.

Example:

```
i8092_DRV_SATRT(1, 0xf);
```

Demo Program: T/S-curve acc/dec motion [Symmetry]

Parameters: cardNo=1, motion axes=0x3 (AXIS_XY)

```
i8092_SET_R(cardNo, 0x3, 800000); // R=800000, Multiple=10
i8092_SET_TCURVE(cardNo, 0x3); // Set T-Curve Mode
i8092_SET_SYMMETRY(cardNo, 0x3); // Set symmetry mode for X, Y axes
i8092_SET_SV(cardNo, 0x3, 100); // SV=100, initial Speed=1000 (PPS)
i8092_SET_V(cardNo, 0x3, 1000); // V=1000, Drive Speed=10000 (PPS)
i8092_SET_A(cardNo, 0x3, 80); // A=80, Acceleration=100K (PPS/Sec)
i8092_SET_PULSE(cardNo, 0x3, 25000); // Driving Pulse=25000
i8092_DRV_HOLD(card, 0x3); // Holding for driving starting
i8092_DRV_FDRIVE(cardNo, 0x3, 0); // X-Axis Positive Fixed Pulse Drive
i8092_DRV_START(card, 0x3); // Holding Release
```

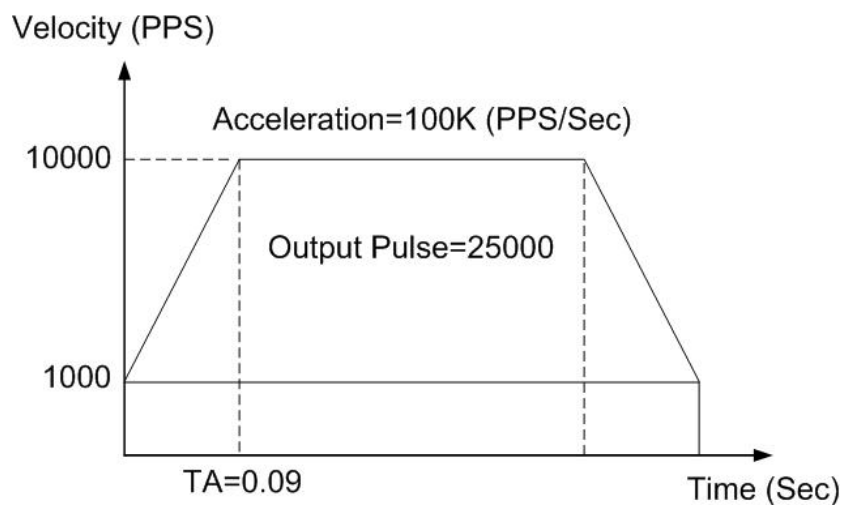

Fig. A-31 Symmetry T-curve acc/dec

Demo Program: T/S-curve acc/dec motion [Asymmetry]

Parameters: cardNo=1, motion axes=0x3 (AXIS_XY)

```
i8092_SET_R(cardNo, 0x3, 8000000); // R=800000, Multiple=10
i8092_SET_SCURVE(cardNo, 0x3); // Set S-Curve Mode
i8092_SET_ASYMMETRY(cardNo, 0x3); // Set Non-Symmetry Mode
i8092_SET_SV(cardNo, 0x3, 100); // SV=100, Initial Speed=1000 (PPS)
i8092_SET_V(cardNo, 0x3, 1000); // V=1000, Drive Speed=10000 (PPS)
i8092_SET_A(cardNo, 0x3, 800); // A=800, Acceleration=1000K (PPS/Sec)
i8092_SET_D(cardNo, 0x3, 80); // D=80, Deceleration=100K (PPS/Sec)
i8092_SET_K(cardNo, 0x3, 1250); // K=1250, Jerk=500K (PPS/Sec2)
i8092_SET_L(cardNo, 0x3, 125); // L=125, Decelerating Rate=50K (PPS/Sec2)
i8092_SET_PULSE(cardNo, 0x3, 50000); // X-Axis Driving Pulse=50000
i8092_DRV_HOLD(card, 0x3); // Holding for driving starting
i8092_DRV_FDRIVE(cardNo, 0x1, 1); // X-Axis Negative Fixed Pulse Drive
i8092_DRV_FDRIVE(cardNo, 0x2, 0); // Y-Axis Positive Fixed Pulse Drive
i8092_DRV_START(card, 0x3); // Holding Release
```

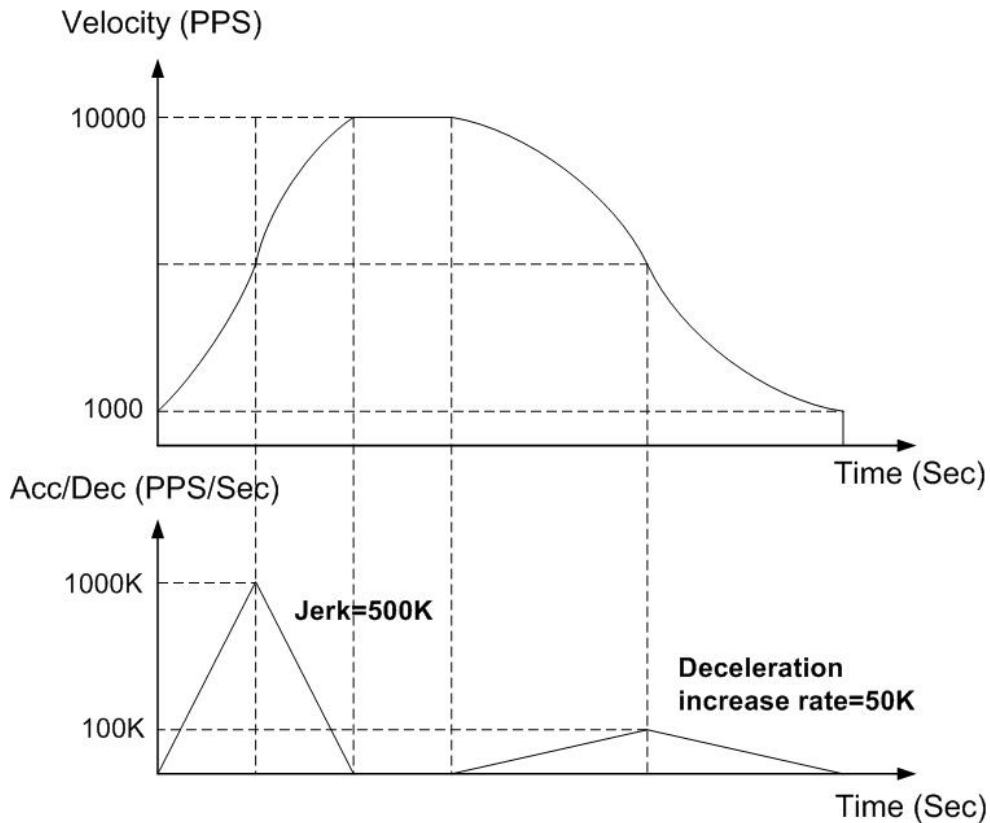

Fig. A-41 Asymmetric S-curve acc/dec

A.7.5 Interpolation Functions

The below figure is the MCX312 Interpolation functional diagram. It consists of same functioned X and Y axes control sections and interpolation counting sections.

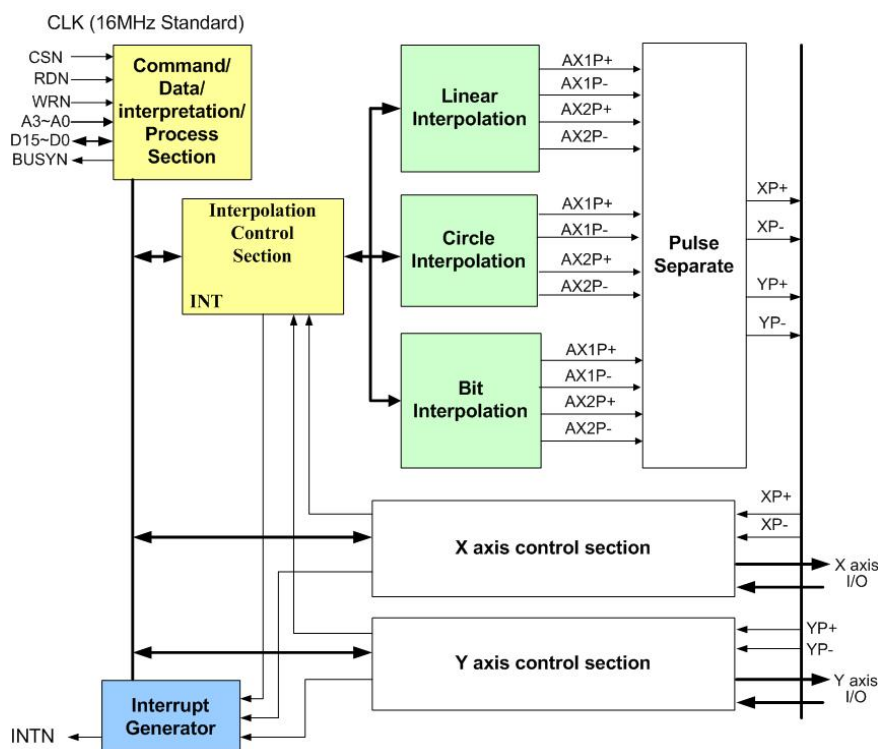

Fig. A-32 MCX312 Functional Block Diagram

Table A-6 Interpolation Functions

Function Name	Description
i8092_MOTION_TYPE	2 or 3-axes constant vector speed setting
i8092_SET_FINISH	Interpolation's finish point setting
i8092_LINE2D	2 axes linear interpolation mode
i8092_SET_CENTER	Circular interpolation's center setting
i8092_ARC_CW	CW direction arc interpolation mode
i8092_ARC_CCW	CCW direction arc interpolation mode
i8092_CIRCLE_CW	CW direction circle interpolation mode
i8092_CIRCLE_CCW	CCW direction circle interpolation mode
i8092_NEXT_WAIT	Wait for next interpolation command
i8092_BP_ENABLE	Bit pattern interpolation enabled
i8092_BP_DISABLE	Bit pattern interpolation disabled
i8092_BP_CLEAR	Bit pattern interpolation cleared
i8092_BP_STACK	Bit pattern data stack
i8092_BP_WAIT	Wait for bit pattern data write

i8092_MOTION_TYPE

Format:

void i8092_MOTION_TYPE(unsigned char CardNo, WORD type)

Function:

Set 2 -axes constant vector speed mode

Parameter:

cardNo is the board number.

type is the parameter setting the constant vector speed modes.

type=0, constant vector speed mode is invalid;

type=1, 2-axes constant vector speed mode.

Example: //Set the 2-axes constant vector mode.

```
i8092_MOTION_TYPE(1, 1);
```

i8092_SET_FINISH

Format:

void i8092_SET_FINISH(BYTE cardNo, WORD axis, long data)

Function:

Set the value of the finish point for motion (in Pulses).

Parameter:

cardNo Module number.

axis axis or axes. Please refer to Table 2-1.

data Pulse number. Range : -2,147,483,648 ~ +2,147,483,648

Example: //set the value of finish point.

```
i8092_SET_FINISH(1, 1, 1000);
```

Linear interpolation functions

About the linear interpolation functions are designed in three modes: constant (tangential) speed, T-curve (tangential) acceleration / deceleration, S-curve (tangential) acceleration / deceleration.

Users need to set the following parameters:

- Range: R
- Initial Speed: SV (PPS)
- Driving Speed: V (PPS)
- Acceleration: A (PPS/Sec)
- Finish Point: FP (Pulses)

i8092_LINE_2D

Format:

`void i8092_LINE_2D(unsigned char CardNo, long fp1, long fp2)`

Function:

Two axes linear interpolation.

Parameter:

cardNo is the board number.

fp1: finish point for axis1, data range is -8388608~8388607.

fp2: finish point for axis2, data range is -8388608~8388607.

Example:

```
i8092_LINE2D(1, 12000, 10000);
```

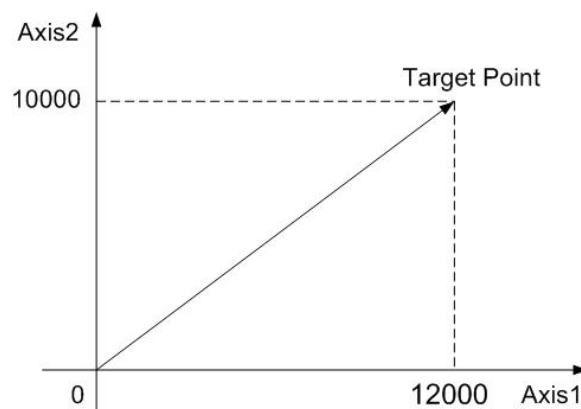

Fig. A-33 2-axes linear interpolation

Demo Program: **linear interpolation**

Parameters: **cardNo=1**

// 2-Axis Linear Interpolation

```
i8092_MOTION_TYPE(cardNo, CONST2); // Set 2-Axes Constant Vector Speed Mode
i8092_SET_R(CardNo, Card[cardNo].ax1, 8000000);
i8092_SET_R(cardNo, Card[cardNo].ax2, 8000000*1414L/1000L);
i8092_SET_V(cardNo, Card[cardNo].ax1, 1000);
i8092_LINE_2D(cardNo, 3000, 4000); // 2-Axes Interpolation
```

Circular Interpolation Functions

i8092_ARC_CW

Format:

```
void i8092_ARC_CW(unsigned char cardNo, long cp1, long cp2,
                  long fp1, long fp2)
```

Function:

CW direction circular interpolation.

Parameters:

cardNo is the board number.

cp1 is the center for axis1.

cp2 is the center for axis2.

fp1 is the finish point for axis1.

fp2 is the finish point for axis2.

Example:

```
i8092_ARC_CW(1, -5000, -5000, -10000, -10000);
```

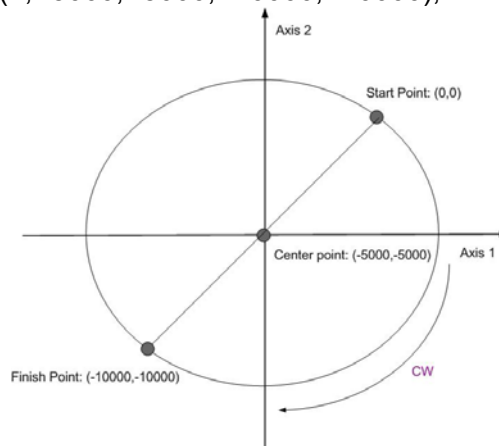

Fig. A-34 CW circular interpolation

i8092_ARC_CCW

Format:

```
void i8092_ARC_CCW(unsigned char cardNo, long cp1, long cp2,  
                  long fp1, long fp2)
```

Function:

CW direction circular interpolation.

Parameters:

cardNo is the board number.

cp1 is the center for axis1.

cp2 is the center for axis2.

fp1 is the finish point for axis1.

fp2 is the finish point for axis2.

Example:

```
i8092_ARC_CCW(1, -5000, -5000, -10000, -10000);
```

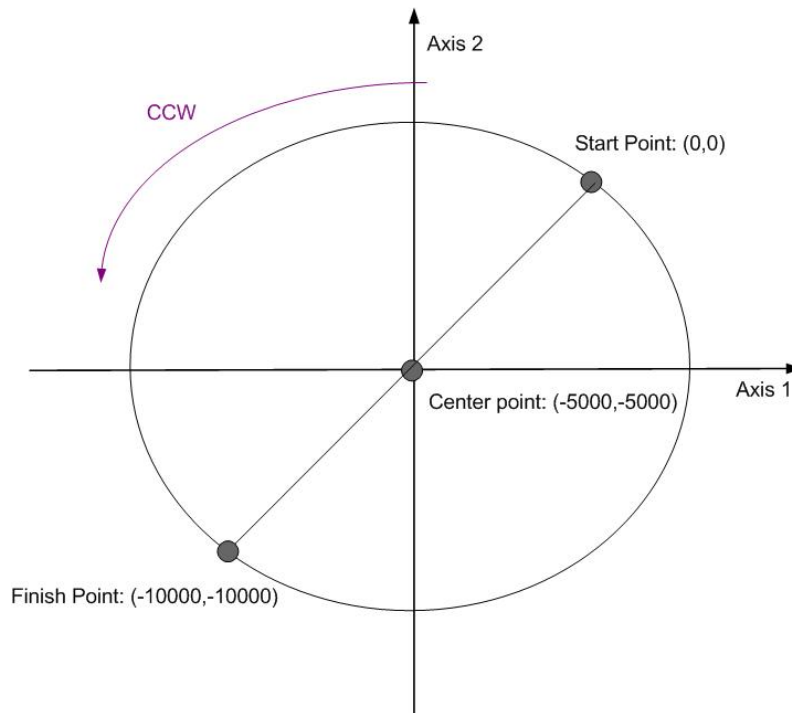

Fig. A-35 CCW circular interpolation

i8092_CIRCLE_CW

Format:

void i8092_CIRCLE_CW(unsigned char cardNo, long cp1, long cp2)

Function:

CW direction circular interpolation.

Parameters:

cardNo is the board number.

cp1 is the center for axis1.

cp2 is the center for axis2.

fp1 is the finish point for axis1.

fp2 is the finish point for axis2.

Example:

```
i8092_CIRCLE_CW(1, 0, 10000);
```

► **Note:** The function is convenient to profile for a total circle, it is accounting to the i8092_ARC_CW function.

i8092_CIRCLE_CCW

Format:

void i8092_CIRCLE_CCW(unsigned char cardNo, long cp1, long cp2)

Function:

CW direction circular interpolation for constant speed.

Parameters:

cardNo is the board number.

cp1 is the center for axis1.

cp2 is the center for axis2.

fp1 is the finish point for axis1.

fp2 is the finish point for axis2.

Example:

```
i8092_CIRCLE_CCW(1, 0, 10000);
```

◆ **Note:** The function is convenient to profile for a total circle, it is accounting to the i8092_ARC_CCW function.

i8092_NEXT_WAIT

Format:

`void i8092_NEXT_WAIT(unsigned char cardNo)`

Function:

Using to waiting for the command of the next segment.

Parameters:

`cardNo` is the board number.

Example:

```
i8092_NEXT_WAIT(1);
```

Continuous interpolation

User can use the linear and circular interpolation to implement a specific curve motion. There are two ways to implement: polling and interrupt. Fig. A-48 shows an example of executing continuous beginning at point (0,0) form segment 1, 2, 3... to the segment 8. In segment 1, 3, 5, and 7, the linear interpolation will be executed; in segment 2, 4, 6, and 8, the circular interpolation will be executed, and the track is a quadrant circle with radius 1500. The interpolation driving is at a constant vector speed: 1500 PPS.

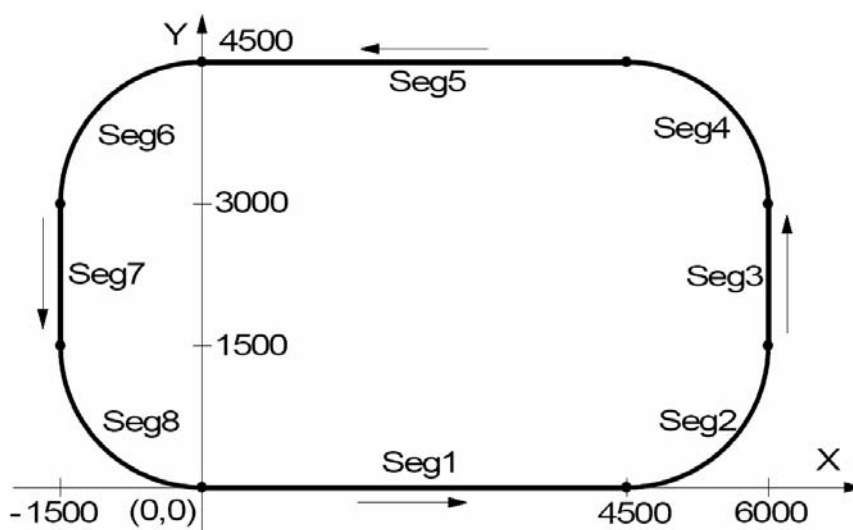

Fig. A-36 Continuous interpolation

Demo Program: Constant Speed Continuous Interpolation

Parameters: CradNo=1

```
i8092_SET_R(cardNo, Card[cardNo].ax1, 800000);
i8092_SET_R(cardNo, Card[cardNo].ax2, 800000* 1414L/1000L);
i8092_MOTION_TYPE(cardNo, 0x3, 1);           // 2-axes constant vector speed
i8092_SET_V(cardNo, Card[cardNo].ax1, 1500); // Set V = SV

i8092_LINE_2D(cardNo, 4500, 0);               // Segment 1
i8092_NEXT_WAIT(cardNo);                    // Wait next command

i8092_ARC_CCW(cardNo, 0, 1500, 1500, 1500); // Segment 2
i8092_NEXT_WAIT(cardNo);                    // Wait next command

i8092_LINE_2D(cardNo, 0, 1500);              // Segment 3
i8092_NEXT_WAIT(cardNo);                    // Wait next command

i8092_ARC_CCW(cardNo, -1500, 0, -1500, 1500); // Segment 4
i8092_NEXT_WAIT(cardNo);                    // Wait next command

i8092_LINE_2D(cardNo, -4500, 0);             // Segment 5
i8092_NEXT_WAIT(cardNo);                    // Wait next command

i8092_ARC_CCW(cardNo, 0, -1500, -1500, -1500); // Segment 6
i8092_NEXT_WAIT(cardNo);                    // Wait next command

i8092_LINE_2D(cardNo, 0, -1500);             // Segment 7
i8092_NEXT_WAIT(cardNo);                    // Wait next command

i8092_ARC_CCW(cardNo, 1500, 0, 1500, -1500); // Segment 8
i8092_STOP_WAIT(cardNo, Card[cardNo].plane);

Delay(500); // Because of the servo lag, In eVC use Sleep(500)
```

Bit Pattern Interpolation Functions

i8092_BP_ENABLE
i8092_BP_DISABLE

Format:

void i8092_BP_ENABLE(unsigned char cardNo)
void i8092_BP_DISABLE(unsigned char cardNo)

Function:

Enable/disable the bit pattern data stack.

Parameters:

cardNo is the board number.

Example:

```
i8092_BP_ENABLE(1);  
i8092_BP_DISABLE(1);
```

i8092_BP_STACK
i8092_BP_CLEAR

Format:

void i8092_BP_STACK(unsigned char cardNo)
void i8092_BP_CLEAR(unsigned char cardNo)

Function:

Stack/clear the bit pattern data.

Parameters:

cardNo is the board number.

Example:

```
i8092_BP_STACK(1);  
i8092_BP_CLEAR(1);
```

i8092_BP_WAIT

Format:

void i8092_BP_WAIT(**unsigned char** cardNo)

Function:

Wait for bit pattern data outputting.

Parameters:

cardNo is the board number.

Example:

```
i8092_BP_WAIT(1);
```

i8092_BP_LINE2D_DEMO

Format:

void i8092_BP_LINE2D_DEMO(**unsigned char** cardNo, **long** p1, **long** p2)

Function:

The linear DDA method for the bit pattern interpolation.

Parameters:

cardNo is the board number.

Example:

```
i8092_BP_LINE2D_DEMO(1, 30, 40);
```

According to the below flow chart, user can use linear interpolation DDA algorithm to produce the BP data. However $L = \sqrt{P_1^2 + P_2^2}$, P_1 , P_2 are the pulse number of each axis.

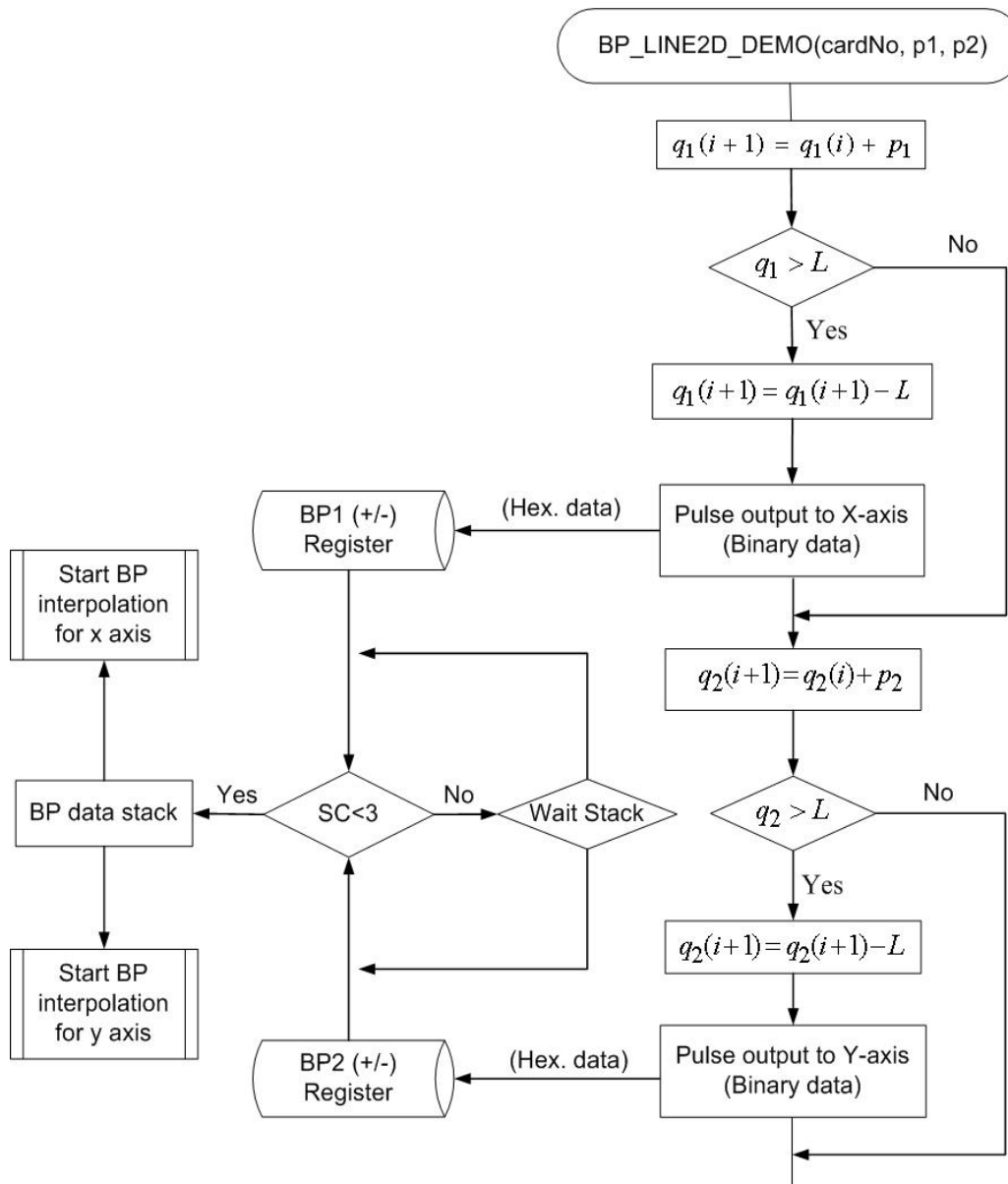

Fig. A-37 Bit pattern interpolation by using the linear DDA method

► **Note:** The following bit pattern demo program is only valid in I-8000. User use the polling method to implement the bit pattern by calling the i8092_BP_LINE2_DEMO function and use interrupt method to implement by calling the i8092_BP_LINE_DEMO_INT function.

Demo Program: Bit pattern interpolation by using the linear DDA data

Parameters: cardNo=1, master axis=0x1 (AXIS_X), 2nd axis=0x2 (AXIS_Y), P1=30, P2=40

```
i8092_AXIS_ASSIGN(cardNo, 0x1, 0x2, 0);  
i8092_MOTION_TYPE(cardNo, ACCMODE );  
i8092_SET_AUTODEC(cardNo, Card[cardNo].plane); // Auto Deceleration Enabled  
i8092_SET_TCURVE(cardNo, Card[cardNo].plane); // Set T-Curve Mode  
i8092_SET_R(cardNo, Card[cardNo].plane, 8000000); // Multiple=1  
i8092_SET_SV(cardNo, Card[cardNo].plane, 50);  
i8092_SET_V(cardNo, Card[cardNo].plane, 500);  
i8092_SET_A(cardNo, Card[cardNo].plane, 80);  
i8092_BP_ENABLE(cardNo); // BP Interpolation Enabled  
i8092_BP_LINE2_DEMO(cardNo, 30, 40); // Linear DDA Data Stack  
i8092_BP_DISABLE(cardNo); // BP Interpolation disabled
```

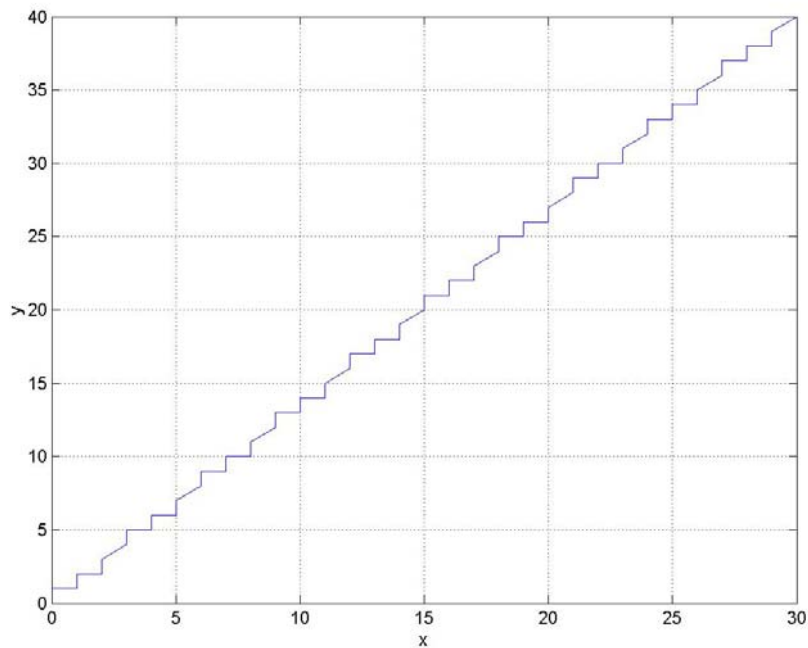

Fig. A-38 Use linear DDA method for bit pattern interpolation

Use the linear DDA method, set P1(X-axis) = 30, P2(Y-axis) = 40, and the linear DDA data are calculated as bellows:

Table A-7 DDA data for the bit pattern interpolation

Index	Z1	Hex1	Z2	Hex2	X	Y	Index	Z1	Hex1	Z2	Hex2	X	Y			
1	0	0x6b5a	0	0x7bde	0	0	26	0	0x5ad6	0	0xdef7	15	20			
2	1		1		1	1	1	1		27		1	1	1	16	21
3	0		1		1	1	1	2		28		0	1	1	16	22
4	1		1		1	1	2	3		29		1	1	1	17	23
5	1		1		1	1	3	4		30		1	1	1	18	24
6	0		0		0	3	4	4		31		0	0	0	18	25
7	1		1		1	4	5	5		32		1	1	1	19	25
8	0		1		1	4	6	6		33		0	1	1	19	26
9	1		1		1	5	7	7		34		1	1	1	20	27
10	1		1		1	6	8	8		35		1	1	1	21	28
11	0		0		0	6	8	9		36		0	0	0	21	29
12	1		1		1	7	9	10		37		1	1	1	22	29
13	0		1		1	7	10	11		38		0	1	1	22	30
14	1		1		1	8	11	12		39		1	1	1	23	31
15	1		1		1	9	12	13		40		1	1	1	24	32
16	0		0		0	9	12	14		41		0	0	0	24	32
17	1	0xb5ad	1	0xbdf7	10	13	42	1	0x3	1	0x3	25	33			
18	0		1		10	14	43	0		1		1	25	34		
19	1		1		11	15	44	1		1		1	26	35		
20	1		1		12	16	45	1		1		1	27	36		
21	0		0		12	16	46	0		0		0	27	36		
22	1		1		13	17	47	1		1		1	28	37		
23	0		1		13	18	48	0		1		1	28	38		
24	1		1		14	19	49	1		1		1	29	39		
25	1		1		15	20	50	1		1		1	30	40		

► **Note:** Z1, Z2 are the output pulse on the each interval, X is the sum of Z1, Y is the sum of Z2, Hex1 is the 16 bits character made of 16 ones or zeros (Z1), and Hex2 is the 16 bits character made of 16 ones or zeros (Z2)

A.7.6 Automatic Home Search

Table A-8 Home Search Function

Function Name	Description
i8092_EXTENSION_MODE	Write data into the WR6, WR7 registers and use 60h command to set the conditions for automatic search mode.
i8092_GET_EM6	i8092_GET_EM6
i8092_GET_EM7	i8092_GET_EM7
i8092_IN0_LEVEL	Setting the active level of the near home signal (IN0).
i8092_IN1_LEVEL	Setting the active level of the home signal (IN1).
i8092_IN2_LEVEL	Setting active level of the encoder Z-phase signal (IN2).
i8092_SET_HV	The home search speed (HV) setting.
i8092_HOME_STEP1	Home search step 1 mode setting.
i8092_HOME_STEP2	Home search step 1 mode setting.
i8092_HOME_STEP3	Home search step 1 mode setting.
i8092_HOME_STEP4	Home search step 1 mode setting.
i8092_HOME_SAND	Home and Encoder Z-phase signal condition setting.
i8092_HOME_LIMIT	The home search uses an overrun limit signal setting.
i8092_HOME_PCLR	Clear the logic position and real position counter at termination home search.
i8092_HOME_START	Start execution of automatic home search.
i8092_HOME_MODE	Set the home search mode.

i8092_EXTENSION_MODE

Format:

```
void i8092_EXTENSION_MODE(unsigned char cardNo, WORD axis,  
                           WORD em6data, WORD em7data)
```

Function:

Write data to the WR6, WR7 registers and uses 64h command to set the conditions for synchronous action mode.

Parameters:

cardNo is the board number.

axis is the motion axis code/name, as shows in Table 2-1.

em6data is the 32-bit data for writing in the WR6 register.

em7data is the 32-bit data for writing in the WR7 register.

Example:

```
//Use the function to set the home search type of negative direction, and hardware  
//signal: home, near home, limit-  
i8092_EXTENSION_MODE(1, 0xf, 0x5f00, 0x054f);
```

i8092_GET_EM6

Format:

WORD i8092_GET_EM6(**BYTE** *cardNo*, **WORD** *axis*)

Function:

Get the data of EM6.

Parameters:

cardNo board number.

axis axis or axes. Please refer to Table 2-1.

Example:

```
//get the EM6 value of the X-axis on card 1  
WORD em6Data;  
em6Data = i8092_GET_EM6(1, 0x1);
```

i8092_GET_EM7

Format:

WORD i8092_GET_EM7(**BYTE** *cardNo*, **WORD** *axis*)

Function:

Get the data of EM7.

Parameters:

cardNo board number.

axis axis or axes. Please refer to Table 2-1.

Example:

```
//get the EM7 value of the X-axis on card 1  
WORD em7Data;  
em7Data = i8092_GET_EM7(1, 0x1);
```

i8092_IN0_LEVEL

Format:

void i8092_IN0_LEVEL(unsigned char cardNo, WORD axis, WORD nLevel)

Function:

Set the logic level of the IN0 signal.

Parameters:

cardNo is the board number.

axis is the motion axis code/name, as shows in [mm 2-1](#).

nLevel is the setting the active level of home signal (IN1).

nLevel=0, Low active; nLevel=1, Hi active.

Example:

```
i8092_IN0_LEVEL(1, 0xf, 0);
```

8092_IN1_LEVEL

Format:

void i8092_IN1_LEVEL(unsigned char cardNo, WORD axis, WORD nLevel)

Function:

Set the logic level of the IN1 signal.

Parameters:

cardNo is the board number.

axis is the motion axis code/name, as shows in [Table 2-1](#).

nLevel is setting the active level of the near home signal (IN0).

nLevel=0, Low active; nLevel=1, Hi active.

Example:

```
i8092_IN1_LEVEL(1, 0xf, 0);
```

i8092_IN2_LEVEL

Format:

void i8092_IN2_LEVEL(unsigned char cardNo, WORD axis, WORD nLevel)

Function:

Set the logic level of the IN2 signal.

Parameters:

cardNo is the board number.

axis is the motion axis code/name, as shows in Table 2-1.

nLevel is the setting the active level of the encoder Z-phase signal (IN2).

nLevel=0, Low active; nLevel=1, Hi active.

Example:

```
i8092_IN2_LEVEL(1, 0xf, 0);
```

i8092_SET_HV

Format:

void i8092_SET_HV(unsigned char cardNo, WORD axis, WORD data)

Function:

Set the home search speed (HV).

Parameters:

cardNo is the board number.

axis is the motion axis code/name, as shows in Table 2-1.

data is the home search speed value. Data range:1~8000

Example: //Set home search speed 1000 (PPS)

```
i8092_SET_HV(1, 0xf, 1000);
```

i8092_HOME_STEP1

Format:

void i8092_HOME_STEP1(**unsigned char** cardNo, **WORD** axis,
WORD nType, **WORD** nDir)

Function:

Use the near home signal (IN0) to operate the home search.

Parameters:

cardNo is the board number.

axis is the motion axis code/name.

nType is the specified the near home signal (IN0) executed or not.

nType= 0, non-execution; nType=1, execution.

nDir is the operation direction of the step.

nDir=0, positive; nDir=1, negative

Example: //Set the step 1 enabled and – negative direction of the home search

```
i8092_HOME_STEP1(1, 0xf, 1, 1);
```

i8092_HOME_STEP2

Format:

void i8092_HOME_STEP2(**unsigned char** cardNo, **WORD** axis,
WORD nType, **WORD** nDir)

Function:

Use the home signal (IN1) to operate the home search.

Parameters:

cardNo is the board number.

axis is the motion axis code/name.

nType is the specified the home signal (IN1) executed or not.

nType= 0, non-execution; nType=1, execution.

nDir is the operation direction of the step.

nDir=0, positive; nDir=1, negative

Example: //Set the step 2 enabled and – negative direction of the home search

```
i8092_HOME_STEP2(1, 0xf, 1, 1);
```

i8092_HOME_STEP3

Format:

void i8092_HOME_STEP3(**unsigned char** cardNo, **WORD** axis,
WORD nType, **WORD** nDir)

Function:

Use the signal (IN2) to operate the home search.

Parameter:

cardNo is the board number.

axis is the motion axis code/name.

nType is the specified the encoder z-phase signal (IN2) executed or not.

nType= 0, non-execution; nType=1, execution.

nDir is the operation direction of the step.

nDir=0, positive; nDir=1, negative

Example: //Set the step 3 enabled and negative direction of the home search

```
i8092_HOME_STEP3(1, 0xf, 1, 1);
```

i8092_HOME_STEP4

Format:

void i8092_HOME_STEP4(**unsigned char** cardNo, **WORD** axis,
WORD nType, **WORD** nDir)

Function:

Set the offset drive in the last step.

Parameter:

cardNo is the board number.

axis is the motion axis code/name.

nType is the specified the near home signal (IN0) executed or not.

nType= 0, non-execution; nType=1, execution.

nDir is the operation direction of the step.

nDir=0, positive; nDir=1, negative

Example: //Set the step 4 enabled and – negative direction of the home search

```
i8092_HOME_STEP4(1, 0xf, 1, 1);
```

i8092_HOME_SAND

Format:

void i8092_HOME_SAND(**unsigned char** cardNo, **WORD** axis, **WORD** nType)

Function:

Set the operation of step 3 when the home signal and the encoder z-phase signal become active.

Parameters:

cardNo is the board number.

axis is the motion axis code/name, as shows in Table 2-1.

nType=0, disable; **nType**=1, enable.

Example: //Disable the SAND (WR7/D9) condition.

```
i8092_HOME_SAND(1, 0xf, 0);
```

i8092_HOME_LIMIT

Format:

void i8092_HOME_LIMIT(**unsigned char** cardNo, **WORD** axis, **WORD** nType)

Function:

Set the home search using an overrun limit signal.

Parameters:

cardNo is the board number.

axis is the motion axis code/name, as shows in Table 2-1.

nType=0, disable; **nType**=1, enable.

Example: //Disable the LIMIT (WR7/D10) condition.

```
i8092_HOME_LIMIT(1, 0xf, 0);
```

i8092_HOME_PCLR

Format:

void i8092_HOME_PCLR(unsigned char cardNo, WORD axis, WORD nType)

Function:

Clear the logic position and real position counter at termination home search.

Parameters:

cardNo is the board number.

axis is the motion axis code/name, as shows in Table 2-1.

nType=0, disable; **nType=1**, enable.

Example: //Enable the PCLR (WR7/D8) condition.

```
i8092_HOME_PCLR(1, 0xf, 0);
```

i8092_HOME_START

Format:

void i8092_HOME_START(unsigned char cardNo, WORD axis)

Function:

Start execution of automatic home search.

Parameters:

cardNo is the board number.

axis is the motion axis code/name, as shows in Table 2-1.

Example: //Start home search operation.

```
i8092_HOME_START(1, 0xf);
```

i8092_HOME_MODE

Format:

void i8092_HOME_MODE(**unsigned char** cardNo,**WORD** axis,
WORD Hometype)

Function:

Home search demo function.

Parameters:

cardNo is the board number.

axis is the motion axis code, as shows in Table 2-1.

HomeType is one of the 8 combination cases of various homing steps. 8 cases are defined in the following table.

Table A-9 Signals for home search types

Home Type	Comment
0	Dir-, hardware signal used: home, near home, limit-
1	Dir+, hardware signal used: home, near home, limit+
2	Dir-, hardware signal used: home, limit- (step1 disabled)
3	Dir+, hardware signal used: home, limit+ (step1 disabled)
4	Dir-, hardware signal used: home, near home, limit-, encoder-Z
5	Dir+, hardware signal used: home, near home, limit+, encoder-Z
6	Dir-, hardware signal used: home, limit-, encoder-Z
7	Dir+, hardware used: home, limit+, encoder-Z

Example: //Set the type 0 of the home search for all axes.

```
i8092_HOME_DEMO(1, 0xf, 0);
```

```
//Start the home search motion.
```

```
i8092_HOME_START(1, 0xf);
```

■ Example of home search using a near home (IN0), home signal (IN1) and Z-phase signal.

■ Operation

	Input signal and logical level	Search direction	Search speed
Step 1	Near home signal (IN0) is active (low)	-	20000 (PPS)
Step 2	Home signal (IN1) is active (low)	-	500 (PPS)
Step 3	Z-phase signal (IN2) is active (high)	+	500 (PPS)
Step 4	35000 pulse offset	+	20000 (PPS)

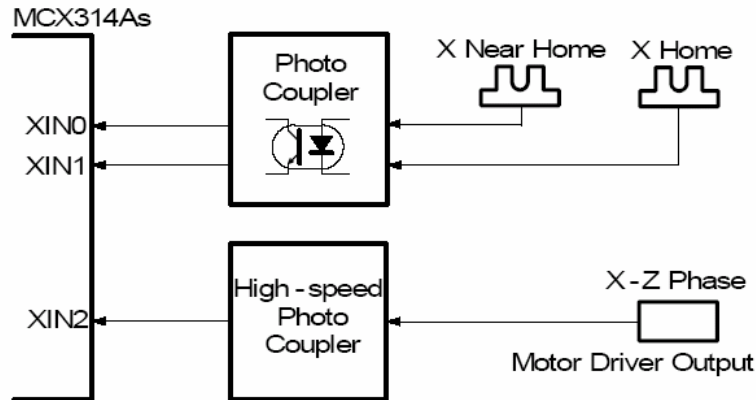

Fig. A-39 Hardware disposition for home operation example 1

► **Note:** In this example, the user should connect the IN0~IN2 signals as shown in the diagram on the left-hand side.

Demo Program: Example of home search using a near home (IN0), home signal (IN1) and the Z-phase signal.

Parameters: cardNo=1, motion axis=0xf (AXIS_ALL)

```

i8092_SET_R(1, 0xf, 800000) // Set Multiple=10
i8092_HLMTM_LEVEL(cardNo, 0xf, 0); // Set negative limit signal of low active
i8092_LMTSTOP_MODE(cardNo, 0xf, 0) // Set Limit stop mode of decelerating stop
i8092_HOME_STEP1(cardNo, 0xf, 1, 1); // Set Step1 is executed and negative direction for 2-axes
i8092_HOME_STEP2(cardNo, 0xf, 1, 1); // Set Step2 is executed and negative direction for 2-axes
i8092_HOME_STEP3(cardNo, 0xf, 1, 0); // Set Step3 is executed and positive direction for 2-axes
i8092_HOME_STEP4(cardNo, 0xf, 1, 0); // Set Step4 is executed and positive direction for 2-axes
i8092_SET_SV(cardNo, 0xf, 500); // Set start velocity=500 (PPS)
i8092_SET_V(cardNo, 0xf, 2000); // Set drive velocity=2000 (PPS)
i8092_SET_A(cardNo, 0xf, 80); // Set acceleration=80 (PPS/Sec)
i8092_SET_HV(cardNo, 0xf, 500); // Set home speed=500 (PPS)
i8092_SET_PULSE(cardNo, 0xf, 20000); // Set offset pulse=20000
i8092_HOME_START(cardNo, 0xf); // Starts execution of automatic home search
i8092_STOP_WAIT(cardNo, 0xf); // Wait drive stop
Sleep(500); // In BC use Delay(500);
i8092_SET_LP(cardNo, axis, 0); // Clear LP counter
i8092_SET_EP(cardNo, axis, 0); // Clear EP counter

```

■ Example of home search using a home signal (IN1) only.

■ Operation

	Input signal and logical level	Search direction	Search speed
Step 1	Near home signal (IN0) is active (low)	-	20000 (PPS)
Step 2	Home signal (IN1) signal active (low)	-	500 (PPS)
Step 3	Not executed		
Step 4	35000 pulse offset	+	20000 (PPS)

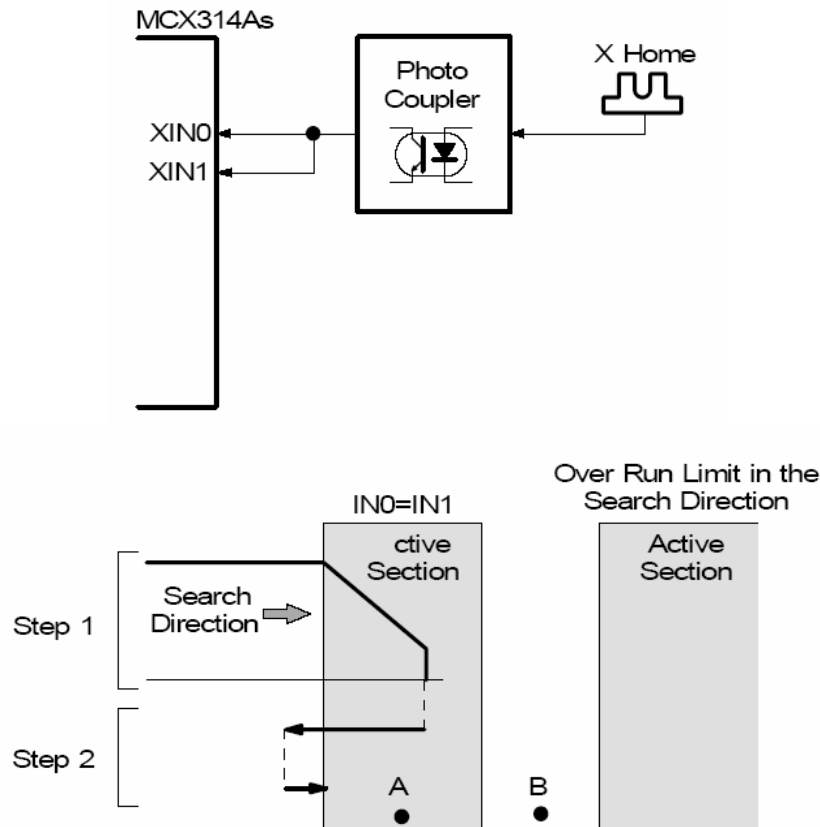

Fig. A-40 Hardware disposition for home operation example 2

Demo Program: Example of home search using a home signal (IN1) only.
Parameters: cardNo=1, motion axis=0xf (AXIS_ALL)

```

i8092_SET_R(cardNo, 0xf, 80000) // Set Multiple=10
i8092_HOME_STEP1(cardNo, 0xf, 1, 1); // Set Step1 is executed and negative direction for 2-axes
i8092_HOME_STEP2(cardNo, 0xf, 1, 1); // Set Step2 is executed and negative direction for 2-axes
i8092_HOME_STEP3(cardNo, 0xf, 0, 0); // Set Step3 is non-executed
i8092_HOME_STEP4(cardNo, 0xf, 1, 0); // Set Step4 is executed and positive direction for 2-axes
i8092_SET_SV(cardNo, 0xf, 500); // Set start velocity=500 (PPS)
i8092_SET_V(cardNo, 0xf, 2000); // Set drive velocity=2000 (PPS)
i8092_SET_A(cardNo, 0xf, 80); // Set acceleration=80 (PPS/Sec)
i8092_SET_HV(cardNo, 0xf, 500); // Set home speed=500 (PPS)
i8092_SET_PULSE(cardNo, 0xf, 20000); // Set offset pulse=20000
i8092_HOME_START(cardNo, 0xf); // Starts execution of automatic home search
i8092_STOP_WAIT(cardNo, axis); // Wait drive stop
Sleep(500); // Delay 500ms, In BC use Delay(500);
i8092_SET_LP(cardNo, axis, 0); // Clear LP counter
i8092_SET_EP(cardNo, axis, 0); // Clear EP counter

```

■ Example of home search using a limit signal only.

■ Operation

	Input signal and logical level	Search direction	Search speed
Step 1	Near home signal (IN0) is active (low)	-	20000 (PPS)
Step 2	Home signal (IN1) signal is active (low)	-	500 (PPS)
Step 3	Not executed		
Step 4	35000 pulse offset	+	20000 (PPS)

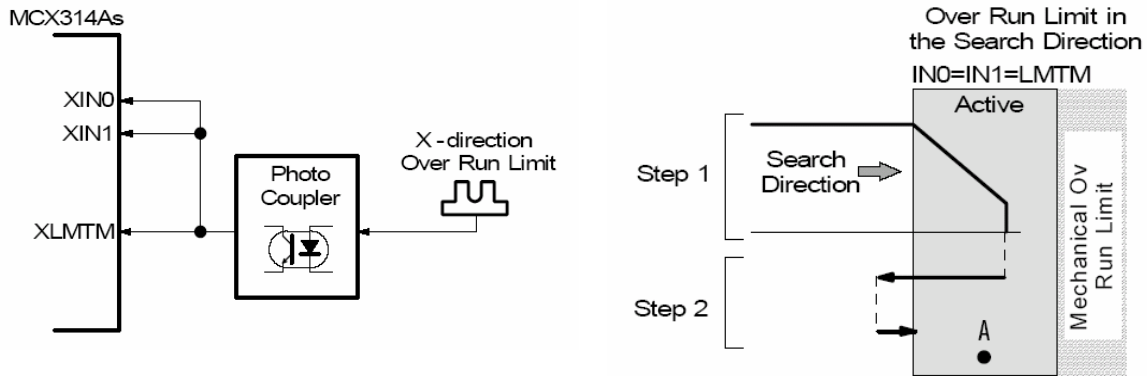

Fig. A-41 Hardware disposition for home operation example 3

Demo Program: Example of home search using a limit signal only.

Parameters: cardNo=1, motion axis=0xf

```

i8092_SET_R(cardNo, 0xf, 80000)           // Set Multiple=10
i8092_HLMTM_LEVEL(1, 0xf, 0);           // Set negative limit signal of low active
i8092_LMTSTOP_MODE(cardNo, 0xf, 0)      // Set Limit stop mode of decelerating stop
i8092_HOME_SAND(cardNo, 0xf, 0);        // Set Z-phase and home signal disabled
i8092_HOME_STEP1(cardNo, 0xf, 1, 1);    // Set Step1 is executed and negative direction for 2-axes
i8092_HOME_STEP2(cardNo, 0xf, 1, 1);    // Set Step2 is executed and negative direction for 2-axes
i8092_HOME_STEP3(cardNo, 0xf, 1, 0);    // Set Step3 is executed and positive direction for 2-axes
i8092_HOME_STEP4(cardNo, 0xf, 1, 0);    // Set Step4 is executed and positive direction for 2-axes
i8092_SET_SV(cardNo, 0xf, 500);         // SV=500, Start Speed=5000 (PPS)
i8092_SET_V(cardNo, 0xf, 2000);         // V=2000, Drive Speed=20000 (PPS)
i8092_SET_A(cardNo, 0xf, 80);           // A=80, Acceleration=10K (PPS/Sec)
i8092_SET_HV(cardNo, 0xf, 500);         // HV=500 Home Speed=5000 (PPS)
i8092_SET_PULSE(cardNo, 0xf, 3500);     // Set offset pulse=3500
i8092_HOME_START(cardNo, 0xf);          // Starts execution of automatic home search
i8092_STOP_WAIT(cardNo, axis);          // Wait drive stop
Delay(500);                              // Delay 500ms, In eVC use Sleep(500);
i8092_SET_LP(cardNo, axis, 0);          // Clear LP counter
i8092_SET_EP(cardNo, axis, 0);          // Clear EP counter

```

A.7.7 Interrupt Function

Table A-10 Synchronous Action functions

函式名稱	敘述
i8092_BPINT_ENABLE	致能位元補間中斷。
i8092_BPINT_DISABLE	除能位元補間中斷。
i8092_CINT_ENABLE	致能連續補間中斷。
i8092_CINT_DISABLE	除能連續補間中斷。
i8092_INTFACTOR_ENABLE	致能各中斷條件因子。
i8092_INTFACTOR_DISABLE	除能各中斷條件因子。

i8092_SYNC_MODE

Format:

void i8092_SYNC_MODE(**unsigned char** cardNo, **WORD** axis,
WORD sm6data, **WORD** sm7data)

Function:

Writes data to the WR6, WR7 registers and uses 64h command to set the conditions for synchronous action mode.

Parameters:

cardNo is the board number.

axis is the motion axis code, as shows in Table 2-1.

sm6data is the data for the WR6 register.

sm7data is the data for the WR6 register.

Example: //Set the X axis (0x1) as the **Provocative** axis, Y axis (0x2) as the **Active** //axis. However the activation factor is the logic position counter value //exceeded the value of COMP+ register ($P \geq C+$), and the action is the positive //fixed pulse driving.
i8092_SET_SYNCMODE(1, 0x1, 0x2001 , 0x0);
i8092_SET_SYNCMODE(1, 0x2, 0x0, 0x0010);

i8092_GET_SB

Format:

void i8092_GET_SB(**unsigned char** cardNo, **WORD** axis)

Function:

Read the synchronous action buffer register.

Parameters:

cardNo is the board number.

axis is the motion axis code/name, as shows in Table 2-1.

Example: //Get the data from the x-axis's buffer register.

```
i8092_GET_SB(1, 0x1);
```

i8092_GET_SM6

Format:

WORD i8092_GET_SM6(**BYTE** cardNo, **WORD** axis)

Function:

Get the value of SM6 register.

Parameters:

cardNo board number

axis axis or axes. Please refer to Table A2-1.

Example: //Get the value of SM6 of X-axis on board 1.

```
WORD sm6Data;
```

```
sm6Data = i8092_GET_SM6(1, 0x1);
```

i8092_GET_SM7

Format:

WORD i8092_GET_SM7(**BYTE** cardNo, **WORD** axis)

Function:

Get the value of SM7 register.

Parameters:

cardNo board number

axis axis or axes. Please refer to Table A2-1.

Example: //Get the value of SM7 of X-axis on board 1.

```
WORD sm7Data ;
```

```
sm7Data = i8092_GET_SM7(1, 0x1);
```

Demo Program: When the X axis is passing through the position 10000, the Y axis starts +direction fixed-pulse drive.

**Parameters: cardNo=1, ProvocativePulse=15000, ActivePulse=30000;
TotalAxis=0x3 (AXIS_XY), ProvocativeAxis=0x1 (AXIS_X), ActiveAxis=0x2 (AXIS_Y)
CompValue=10000**

```
// Set parameters s for total axes or you can also set for individual axis
i8092_SET_SV(cardNo, TotalAxis, 100);
i8092_SET_V(cardNo, TotalAxis, 3000);
i8092_SET_A(cardNo, TotalAxis, 160);
// Set output pulse for the provocative axis
i8092_SET_PULSE(cardNo, ProvocativeAxis, ProvocativePulse);
// Set output pulse for active axis
i8092_SET_PULSE(cardNo, ActiveAxis, ActivePulse);

// Set a boundary condition COMP+ in the provocative axis
i8092_SET_CP(cardNo, ProvocativeAxis, CompValue);
// Disable the software limit
for(i=0;i<4;i++)
{
    i8092_SET_WR2(cardNo, 1<<i, Reg[cardNo].WR2[i]&~0x0003);
}
// Provocative factor: P>=C+
i8092_SYNC_MODE(cardNo, ProvocativeAxis, 0x2001, 0x0);
i8092_COMMAND(cardNo, ProvocativeAxis, 0x20);
// Action of the active axis → +direction fixed-pulse drive
i8092_SYNC_MODE(cardNo, ActiveAxis, 0x0, 0x0001);
i8092_COMMAND(cardNo, ActiveAxis, 0x20);
```

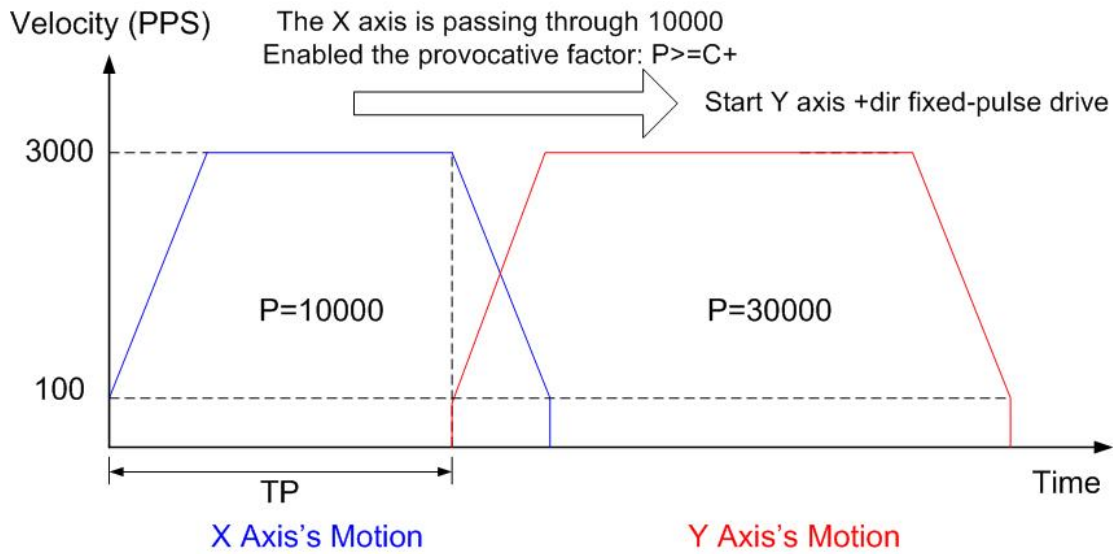

Fig. A-42 Synchronous action example 1

Demo Program: At first the X,Y axes continuous drive, when the X axis is passing through the position -10000, the Y axis stops.

Parameters: cardNo=1, ProvocativePulse=15000, ActivePulse=30000;
TotalAxis=0x3 (AXIS_XY), ProvocativeAxis=0x1 (AXIS_X), ActiveAxis=0x2 (AXIS_Y)
CompValue=10000

// Set parameters s for total axes or you can also set for individual axis

i8092_SET_SV(cardNo, AXIS_X, 100);

i8092_SET_V(cardNo, AXIS_X, 3000);

i8092_SET_A(cardNo, AXIS_X, 160);

i8092_SET_SV(cardNo, AXIS_Y, 100);

i8092_SET_V(cardNo, AXIS_Y, 2000);

i8092_SET_A(cardNo, AXIS_Y, 80);

// Set output pulse for the provocative axis

i8092_SET_PULSE(cardNo, ProvocativeAxis, ProvocativePulse);

// Set output pulse for active axis

i8092_SET_PULSE(cardNo, ActiveAxis, ActivePulse);

// Set a boundary condition COMP- in provocative axis

i8092_SET_CM(cardNo, ProvocativeAxis, CompValue);

// Disable the software limit

for(i=0;i<4;i++)

{

 i8092_SET_WR2(cardNo, 1<<i, Reg[cardNo].WR2[i]&~0x0003);

}

// -Direction continuous drive for the provocative axis

i8092_COMMAND(cardNo, ProvocativeAxis, 0x21);

// Action of the active axis ---> Stop

i8092_SYNC_MODE(cardNo, ActiveAxis, 0x0, 0x0010);

// +Direction continuous drive for the active axis

i8092_COMMAND(cardNo, ActiveAxis, 0x21);

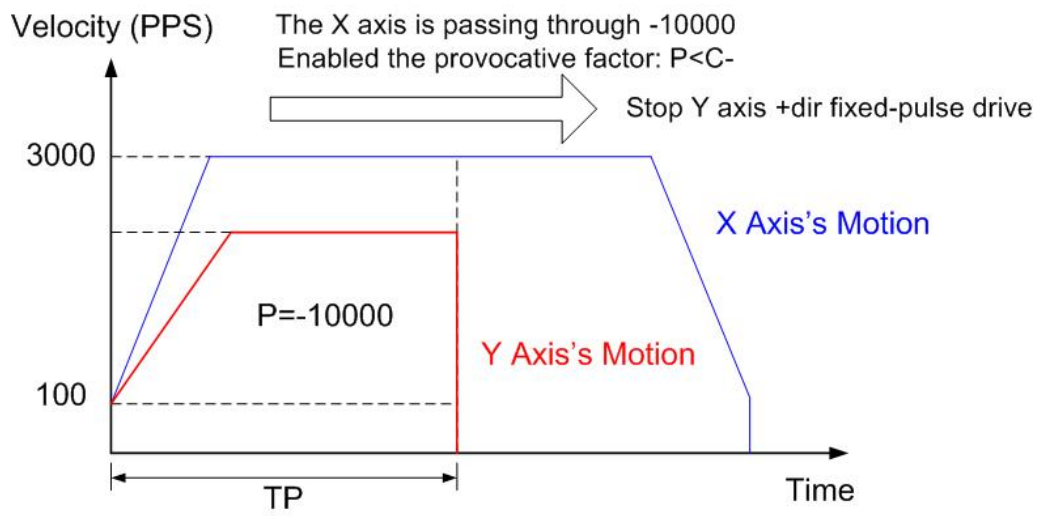

Fig. A-43 Synchronous action example 2

Demo Program: Advanced application for synchronous motion: X,Y axes circular interpolation + Z axis fixed-pulse drive

Parameters: cardNo=1, tempSV=100 (initial speed for XY circular interpolation), tempV=2000 (Drive speed for XY circular interpolation), tempA=80 (The acceleration for XY interpolation), tempVZ=687 (The constant speed for Z axis), tempDP=13963 (Deceleration point for XY circular interpolation)

Description: Set the inclined plane is X,Y-axes and the vertical plane is Z-axis
And the radius of the circle is 5000 and the angle of inclination is 30.

```
// Set parameters s for total axes or you can also set for individual axis
i8092_SET_SV(cardNo, TotalAxis, tempSV);
i8092_SET_V(cardNo, TotalAxis, tempV);
i8092_SET_A(cardNo, TotalAxis, tempA);
// Select the master axis
i8092_AXIS_ASSIGN(cardNo, AXIS_X, AXIS_Y, 0);
// Acc mode setting
i8092_MOTION_TYPE(cardNo, ACCMODE);
// T-curve acc mode setting
i8092_SET_TCURVE(cardNo, Card[cardNo].plane);
// Deceleration enabled
i8092_DEC_ENABLE(cardNo);
// 2-axes circular interpolation mode setting
i8092_SET_R(cardNo, Card[cardNo].ax1, 8000000L);
i8092_SET_R(cardNo, Card[cardNo].ax2, 8000000L *1414L/1000L);
// Set parameters for X,Y axes
i8092_SET_SV(cardNo, AXIS_X, tempSV);
i8092_SET_V(cardNo, AXIS_X, tempV);
i8092_SET_A(cardNo, AXIS_X, tempA);
// Set parameters for Z axis
i8092_SET_R(cardNo, AXIS_Z, templong);
i8092_SET_SV(cardNo, AXIS_Z, tempVZ);
i8092_SET_V(cardNo, AXIS_Z, tempVZ);

// Synchronous action provocative factor: D-STA
// 1st seg
i8092_SYNC_MODE(cardNo, AXIS_X, 0x4010, 0x0000);
i8092_SYNC_MODE(cardNo, AXIS_Z, 0x0000, 0x0002);
i8092_SET_MANDEC(cardNo, AXIS_X, tempDP);
i8092_ARC_CW(cardNo, 0, -5000, 0, -10000);
i8092_SET_PULSE(cardNo, AXIS_Z, 5000);
i8092_DRV_FDRIVE(cardNo, AXIS_Z, 1);
// Wait for drive stop
i8092_STOP_WAIT(cardNo, AXIS_XYZ);
```

A.7.8 FRnet Related Functions

Table A-14 FRnet related functions

Function Name	Description
i8092_FRNET_SA	Write data to digital output of FRnet interface.
i8092_FRNET_RA	Read digital input from FRnet interface.

i8092_FRNET_SA

Format:

void i8092_FRNET_SA(**BYTE** cardNo, **WORD** wSA, **WORD** data)

Function:

This function write data to the FRnet digital output. **SA** means the **Sending Address** which can be one of the legal group number of FRnet. One group comprises 16 bits data. Therefore, total 128 DO can be defined for one FRnet interface.

Parameters:

cardNo is the board number.

wSA: Group number, range 0~7
8~15 are used for digital inputs

data: 16-bit data

Return:

WORD 16-bit DI data

Example:

```
WORD IN_Data;
```

```
IN_Data = i8092_FRNET_RA(1, 8);
```

```
//Read the 16-bit DI which is on module 1 and the group number is 8.
```

i8092_FRNET_RA

Format:

void i8092_FRNET_RA(**BYTE** cardNo, **WORD** wRA)

Function:

This function reads the FRnet digital input signals. **RA** means the *Receiving Address* which can be one of the legal group number of FRnet. One group comprises 16 bits data. Therefore, total 128 DI can be defined for one FRnet interface.

Parameters:

cardNo is the board number.

wRA: Group number, range 8~15
0~7 are used for digital outputs

data: 16-bit data

Return:

None

Example:

```
i8092MF_FRNET_SA(1, 0, 0xffff);
```

```
//Write 0xffff to the 16-bit DO which is on module 1 and the group number is 0.
```

A.8 i8092 Command Lists

For the advanced users who can develop their applications by using the basic function, several lists of command codes and their corresponding ranges are listed below. For more information, users can refer to the manual of MCX312 motion chip.

A.8.1 Data Setting Commands

Symbol	Code	Command	Data Range	Data length (Byte)
R	00h	Range setting	8,000,000~16,000	4
K	01h	Acc rate (Jerk) setting	0 ~ 65,535	2
A	02h	Acceleration (Acc) setting	1 ~ 8,000	2
D	03h	Deceleraton (Dec) setting	1 ~ 8,000	2
SV	04h	Initial speed setting	1 ~ 8,000	2
V	05h	Driving speed setting	1 ~ 8,000	2
P	06h	Output pulse numbers	0~+2 ²⁸	4
FP	06h	Finish point setting	-2 ³¹ ~+2 ³¹	4
DP	07h	Manual deceleration point setting	0 ~ 65,535	2
C	08h	Circular center point setting	-2 ³¹ ~+2 ³¹	4
LP	09h	Logical position counter setting	-2 ³¹ ~+2 ³¹	4
EP	0Ah	Real position counter setting	-2 ³¹ ~+2 ³¹	4
CP	0Bh	COMP+ register setting	-2 ³¹ ~+2 ³¹	4
CM	0Ch	COMP- register setting	-2 ³¹ ~+2 ³¹	4
AO	0Dh	Acceleration counter offset setting	0~65535	2

A.8.2 Data Reading Commands

Symbol	Code	Command	Data Range	Data Length (Byte)
LP	10h	Logic position counter reading	-2 ³¹ ~+2 ³¹	4
EP	11h	Real position counter reading	-2 ³¹ ~+2 ³¹	4
CV	12h	Current driving speed reading	1 ~ 8,000	2
CA	13h	Current Acc/Dec value reading	1 ~ 8,000	2
SB	14h	Synchronous buffer register reading	-2 ³¹ ~+2 ³¹	4

A.8.3 Driving Commands

Code	Command
20h	+ direction fixed pulse driving
21h	- direction fixed pulse driving
22h	+ direction continuous driving
23h	- direction continuous driving
24h	Drive start holding
25h	Drive start holding release / stop status clear
26h	Decelerating stop
27h	Sudden stop

A.8.4 Interpolation Commands

Code	Command
30h	2-axis linear interpolation
31h	3-axis linear interpolation
32h	CW circular interpolation
33h	CCW circular interpolation
34h	2-axis bit pattern interpolation
35h	3-axis bit pattern interpolation
36h	BP register writing enable
37h	BP register writing disable
38h	BP data stack
39h	BP data clear
3Ah	1-step interpolation
3Bh	Deceleration valid
3Ch	Deceleration invalid
3Dh	Interpolation interrupt clear

A.8.5 Other commands

Code	Command
62h	Automatic home search execution
65h	Synchronous action activation
0Fh	NOP (for axis switching)

Appendix B: MCX312 Registers

This part gives the users some references about how to access the registers in the MCX312 chip. For more details, users still have to refer to this chip's manual provided by NOVA electronics Inc..

B.1 Command Register: WR0

Command register is used for the axis assignment and command registration for each axis in MCX312. The register consists of the bit for axis assignment, bit for setting command code, and bit for command resetting.

After the axis assignment and command code have been written to the register, this command will be executed immediately. The data such as drive speed setting and data writing command must be written to registers WR6 and WR7 first. Otherwise, when the reading command is engaged, the data will be written and set, through IC internal circuit, to registers RR6 and RR7. When using the 8-bit data bus, the user should write data into the high word byte (H), then low word byte (L).

It requires 250 nSEC (maximum) to access the command code when CLK=16MHz. The input signal BUSYN is on the Low level at this moment. Please don't write the next command into WR0 before BUSYN return to the Hi level.
WR0

D15	D14	D13	D12 ^H	D11	D10	D9	D8	D7	D6	D5	D4	D3 ^L	D2	D1	D0
RESET	0	0	0	0	0	Y	X	0	0						

Axis Assignment Command Code

D5 ~ 0 Command code setting Please refer to chapter 5 and the chapters following for further description of command codes.

D9 ~ 8 Axis assignment When the bits of the axis are set to 1, the axis is assigned. The assignment is not limited only for one axis, but for multi-axes simultaneously. It is possible to write the same parameters also. However, the data reading is only for one assigned axis. Whenever the interpolation is commanded, the bits of the assigned axis (axes) should be set 0.

D15 RESET IC command resetting When this bit is set to 1, but others are 0, the IC will be reset after command writing. After command writing, the BUSYN signal will be on the Low level within 875 nSEC (When CLK=16 MHz) maximum. When 8-bit data bus is used, the reset is activated when the command (80h) is written to register WR0H.

RESET bit should be set to 0 when the other commands are written.

B.2 Mode Register1: WR1

Each axis is with mode register WR1. The axis specified by NOP command or the condition before decides which axis' s register will be written. The register consists of the bit for setting enable / disable and enable logical levels of input signal STOP2~STOP0 (decelerating stop / sudden stop during the driving) and bit for occurring the interrupt enable / disable. Once SP2~SP0 are active, when the fixed / continuous driving starts, and also when STOP signal becomes the setting logical level, the decelerating stop will be performed during the acceleration / deceleration driving and the sudden stop will be performed during the constant speed driving.

WR1

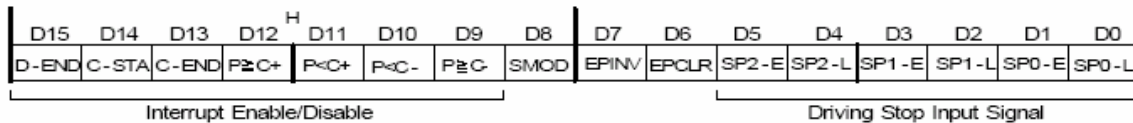

- D5,3,1 SPM-E** The bit for setting enable / disable of driving stop input signal STOPm 0: disable, 1: enable
- D4,2,0 SPM-L** The bit for setting enable logical levels for input signal STOPm 0: stop on the Low level, 1:stop on the Hi level
- D6 EPCLR** When driving stops triggered by the nSTOP2 signal, the real position counter is cleared. When the nSTOP2 signal is changed to the Active level while this bit is set to 1, the driving stops and the real position counter (EP) is cleared. The WR1/D5(SP2-E) bit must be set to 1 and the Enable level must be set in the WR1/D4(SP2-L) bit.
- D7 EPINV** Reverse increase / decrease of real position counter.

D7 (EPINV)	Input pulse mode	Increase / Decrease of real position counter
0	A / B -phase mode	Count up when A -phase is advancing Count down when B -phase is advancing
	Up-Down pulse mode	Count up when PPIN pulse input Count down when PMIN pulse input
1	A / B -phase mode	Count up when B -phase is advancing Count down when A -phase is advancing
	Up-Down pulse mode	Count up when PMIN pulse input Count down when PPIN pulse input

D8 SM0D Setting for prioritizing to reach specified drive speed during S curve acceleration / deceleration driving. 1: enable
For the following bits, the interrupt is set: 1: enable, 0: disable

- D9** $P \geq C-$ Interrupt occurs when the value of logical / real position counter is larger than or equal to that of COMP- register
- D10** $P < C-$ Interrupt occurs when the value of logical / real position counter is smaller than that of COMP- register
- D11** $P < C+$ Interrupt occurs when the value of logical / real position counter is smaller than that of COMP+ register
- D12** $P \geq C+$ Interrupt occurs when the value of logical / real position counter is larger than or equal to that of COMP+ register
- D13** **C-END** Interrupt occurs at the start of the constant speed drive during an acceleration / deceleration driving
- D14** **C-STA** Interrupt occurs at the end of the constant speed drive during an acceleration / deceleration driving
- D15** **D-END** Interrupt occurs when the driving is finished

D15~D0 will be set to 0 while resetting.

B.3 Mode Register2: WR2

Each axis is with mode register WR2. The axis specified by NOP command or the condition before decides which axis' s register will be written.

WR2 can be used for setting: (1). external limit inputs, (2). driving pulse types, (3). encoder signal types, and (4). the feedback signals from servo drivers.

D15	D14	D13	D12	H				D7	L							D0
INP-E	INP-L	ALM-E	ALM-L	PIND1	PIND0	PINMD	DIR-L	PLS-L	PLSMD	CMPSL	HLMT-	HLMT+	LMTMD	SLMT-	SLMT+	

- D0 SLMT+** Enable / disable setting for COMP+ register which is used as the + direction software limit 1: enable, 0: disable
Once it is enabled during the + direction driving, if the value of logical / real position counter is larger than that of COMP+, the decelerating stop will be performed. The D0 (SLMT+) bit of register RR2 will become 1. Under this situation, further written + direction driving commands will not be executed.
Note: When a position counter variable ring is used, a software over run limit cannot be used.
- D1 SLMT-** Enable / disable setting for COMP- register which is used as the - direction software limit 1: enable, 0: disable
Once it is enabled during the - direction driving, if the value of logical / real position counter is smaller than that of COMP-, the decelerating stop will be performed. The D1 (SLMT-) bit of register RR2 will become 1. Under this situation, further written - direction driving commands will not be executed.
- D2 LMTMD** The bit for controlling stop type when the hardware limits are active
(nLMTTP and nLMTM input signals)
0: sudden stop, 1: decelerating stop
- D3 HLMT+** Setting the logical level of + direction limit input signal (nLMTTP) 0: active on the Low level, 1: active on the Hi level
- D4 HLMT-** Setting the logical level of - direction limit input signal (nLMTM) 0: active on the Low level, 1: active on the Hi level
- D5 CMPSL** Setting if real position counter or logical position counter is going to be compared with COMP +/- register
0: logical position counter, 1 : real position counter
- D6 PLSMD** Setting output pulse type 0: independent 2-pulse type, 1: 1-pulse 1-direction type

When independent 2-pulse type is engaged, + direction pulses are output through the output signal nPP/PLS, and – direction pulses through nPM/DIR.
 When 1-pulse 1-direction type is engaged, + and – directions pulses are output through the output signal nPP/PLS, and nPM/DIR is for direction signals.
 [Note] Please refer to Chapter 13.2 and 13.3 for the output timing of pulse signal (nPLS) and direction signal (nDIR) when 1-pulse 1-direction type is engaged.

D7 PLS-L Setting logical level of driving pulses 0: positive logical level, 1: negative logical level



D8 DIR-L Setting logical level of the direction (nPM/DIR) output signal for 1-pulse mode DIR-L

D8 (DIR-L)	+ direction	- direction
0	Low	Hi
1	Hi	Low

D9 PINMD Setting the type of encoder input signals (nECA/PPIN and nECB/PMIN)

0: quadrature pulse input type 1: Up / Down pulse input type
 Real position counter will count up or down when encoder input signal is triggered. When quadrature pulse input type is engaged, the “count up” will happen if the positive logical level pulses are input to phase A; the “count down” will happen if the positive logical level pulses are input to phase B. So, it will count up and down when these 2 signals go up (↑) and down (↓).

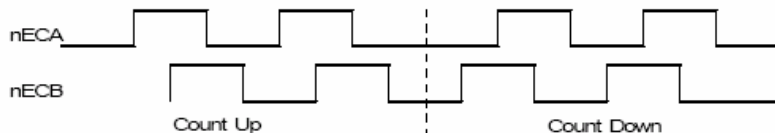

When Up / Down pulse input type is engaged, nECA/PPIN is for “count up” input, and nECB/PMIN is for “count down” input. So, it will count up when the positive pulses go up (↑).

D11,10 PIND1,0 The division setting for quadrature encoder input.

D11	D10	Division
0	0	1/1
0	1	1/2
1	0	1/4

1	1	Invalid
---	---	---------

Up / down pulse input is not available.

- D12 ALM-L** Setting active level of input signal nALARM 0: active on the Low level, 1: active on the Hi level
- D13 ALM-E** Setting enable / disable of servo alarm input signal nALARM 0: disable, 1: enable
When it is enabled, MCX312 will check the input signal. If it is active, D14 (ALARM) bit of RR2 register will become 1. The driving stops.
- D14 INP-L** Setting logical level of nINPOS input signal 0: active on the Low level, 1: active on the Hi level
- D15 INP-E** Setting enable/disable of in-position input signal nINPOS from servo driver 0: disable, 1: enable
When it is enabled, bit n-DRV of RR0 (main status) register does not return to 0 until nINPOS signal is active after the driving is finished.

D15~D0 will be set to 0 while resetting.

B.4 Mode Register3: WR3

Each axis is with mode register WR3. The axis specified by NOP command or the condition before decides which axis' s register will be written. WR3 can be used for manual deceleration, individual deceleration, S-curve acceleration / deceleration, the setting of external operation mode, the setting of input signal filter, and so on.

WR3

D15	D14	D13	D12 ^H	D11	D10	D9	D8	D7	D6	D5	D4 ^L	D3	D2	D1	D0
FL2	FL1	FL0	FE4	FE3	FE2	FE1	FE0	OUTSL	VRING	AVTRI	EXOP1	EXOP0	SACC	DSNDE	MANLD

D0 MANLD Setting manual / automatic deceleration for the fixed acceleration / deceleration driving

0: automatic deceleration, 1: manual deceleration The decelerating point should be set if the manual deceleration mode is engaged.

D1 DSNDE Setting decelerating rate which is in accordance with the rate of the acceleration or an individual decelerating rate

0: acceleration, 1: deceleration

When 0 is set, acceleration value is used as acceleration / deceleration during acceleration / deceleration driving. When 1 is set, acceleration value is used during acceleration driving and deceleration value is used during deceleration driving. 1 should be set for non-symmetrical trapezoidal acceleration / deceleration driving.

D2 SACC Setting trapezoidal driving / S-curve driving

0: trapezoidal driving, 1: S-curve driving

Before S-curve driving is engaged, jerk (K) should be set.

D4,3 EXOP1,0 Setting the external input signals (nEXPP, nEXPM) for driving

D4 (EXOP1)	D3 (EXOP0)	
0	0	external signals disabled
0	1	continuous driving mode
1	0	fixed driving mode
1	1	manual pulsar mode

When the continuous driving mode is engaged, the + direction drive pulses will be output continuously once the nEXPP signal is on the Low level; the - direction pulses will be output continuously once the nEXPM signal is on the Low level. When the fixed driving mode is engaged, the + direction fixed driving starts once the nEXPP signal is falling to the Low level from the Hi level; the - direction fixed driving starts once the nEXPM signal is falling to the Low level from the Hi level. In manual pulsar mode, fixed driving in the + direction is activated at \uparrow of the nEXPP signal when the nEXPM signal is at the Low level. The fixed driving is activated at \downarrow of the nEXPP signal when the nEXPM signal is at the Low level.

- D5 AVTRI Prevent triangle waveforms during fixed driving at the trapezoidal acceleration / deceleration. 0: disable, 1: enable.
[Note] WR3/D5 bit should be reset to 0 when continuous driving is performed after fixed driving.
- D6 VRING Enable the variable ring function of logical position and real position counter. 0: disable, 1: enable.
- D7 OUTSL Driving status outputting or used as general purpose output signals (nOUT7~0)

0: nOUT7~0: general purpose output

The setting of each bit in WR4 register will be output to nOUT7~0.

1: nOUT7~0: driving status output (see the table below)

Signal Name	Output Description
nOUT0/ACASND	When acceleration or deceleration of S curve acceleration / deceleration increases, the level becomes Hi.
nOUT1/ACDSND	When acceleration or deceleration of S curve acceleration / deceleration decreases, the level becomes Hi.
nOUT2/CMPP	Hi: if logical / real position counter \geq COMP+ register Low : if logical / real position counter $<$ COMP+ register
nOUT3/CMPM	Hi: if logical / real position counter $<$ COMP- register Low: if logical / real position counter \geq COMP- register
nOUT4/DRIVE	When drive pulse is outputting, the level becomes Hi.
nOUT5/ASND	When the driving command is engaged, the level becomes Hi once the driving status is in acceleration.
nOUT6/CNST	When the driving command is engaged, the level becomes Hi once the driving status is in constant speed driving.
nOUT7/DSND	When the driving command is engaged, the level becomes Hi once the driving status is in deceleration.

D12~8 FE4~0 Set whether the input signal filter function enables or signal passes through. 0: through, 1: enable.

Specification bit	Filter Enable signal
D8 FE0	EMGN ^{*2} , nLMTP, nLMTM, nSTOP0, nSTOP1
D9 FE1	nSTOP2
D10 FE2	nINPOS, nALARM
D11 FE3	nEXPP, nEXPM
D12 FE4	nIN0, nIN1, nIN2, nIN3, nIN4, nIN5

*2: The EMGN signal is set using the D8 bit of the WR3 register of the X axis.

D15~13 FL2~0 Set a time constant of the filter.

FL2 ~ 0	Removable maximum noise width	Input signal delay time
0	1.75 μ SEC	2 μ SEC
1	224 μ SEC	256 μ SEC
2	448 μ SEC	512 μ SEC
3	896 μ SEC	1.024mSEC
4	1.792mSEC	2.048mSEC
5	3.584mSEC	4.096mSEC
6	7.168mSEC	8.192mSEC
7	14.336mSEC	16.384mSEC

D15~D0 will be set to 0 while resetting.

B.5 Output Register: WR4

This register is used for setting the general purpose output signals nOUT7~0. This 16-bit register locates 8 output signals of each axis. It can be also used as a 16-bit general purpose output. It is Low level output when the bit is set 0, and Hi level output when the bit is set 1.

D15	D14	D13	D12 ^H	D11	D10	D9	D8	D7	D6	D5	D4 ^L	D3	D2	D1	D0
YOUT7	YOUT6	YOUT5	YOUT4	YOUT3	YOUT2	YOUT1	YOUT0	XOUT7	XOUT6	XOUT5	XOUT4	XOUT3	XOUT2	XOUT1	XOUT0

D15~D0 will be set to 0 while resetting, and nOUT7~0 signals become Low level.

4.8 Interpolation Mode Register: WR5

This register is used for setting constant vector speed mode, multichip interpolation mode, 1-step interpolation mode and interrupt during the interpolation.

D15	D14	D13	D12 ^H	D11	D10	D9	D8	D7	D6	D5	D4 ^L	D3	D2	D1	D0
BPINT	CIINT	CMPLS	EXPLS	MLT1	MLT0	LSPD1	LSPD0	0	0	0	0	0	0	0	0
Interrupt		Step		multichip		Constant Vector Speed									

D9,8 LSPD1,0 Constant vector speed mode setting of interpolation driving
D15~D0 will be set to 0 while resetting.

D9	D8	Code (Binary)
0	0	constant vector speed invalid
0	1	2-axis constant vector speed
1	0	(setting not available)
1	1	(setting not available)

When 2-axis constant vector speed mode is engaged, the user should set the range (R) of the Y axis to be 1.414 times of the range (R) of the X axis.

D11,10
MLT1,0

Multichip interpolation mode setting

D11	D10	Setting
0 0 1	0 1	disable multichip interpolation main chip sub chip X,
1	0 1	Y (Both X and Y axes use) sub chip (Only X axis)

- D12 **EXPLS** When it is 1, the external (MPLS) controlled single step interpolation mode is engaged.
- D13 **CMPLS** When it is 1, the command controlled single step interpolation mode is engaged.
- D14 **CIINT** Interrupt enable / disable setting during interpolation 0: disable
1: enable
- D15 **BPINT** Interrupt enable / disable setting during bit-pattern interpolation
0: disable 1: enable

B.7 Data Register: WR6/WR7

Data registers are used for setting the written command data. The low-word data-writing 16-bit (WD15~WD0) is for register RR6 setting, and the high-word data-writing 16-bit (WD31~WD16) is for register RR7 setting.

WR6

D15	D14	D13	D12 ^H	D11	D10	D9	D8	D7	D6	D5	D4 ^L	D3	D2	D1	D0
WD15	WD14	WD13	WD12	WD11	WD10	WD9	WD8	WD7	WD6	WD5	WD4	WD3	WD2	WD1	WD0

WR7

D15	D14	D13	D12 ^H	D11	D10	D9	D8	D7	D6	D5	D4 ^L	D3	D2	D1	D0
WD31	WD30	WD29	WD28	WD27	WD26	WD25	WD24	WD23	WD22	WD21	WD20	WD19	WD18	WD17	WD16

The user can write command data with a designated data length into the write register. It does not matter to write WR6 or WR7 first (when 8-bit data bus is used, the registers are WR6L, WR6H, WR7L and WR7H).

The written data is binary formatted; 2' complement is for negatives. For command data, the user should use designated data length. For instance, the circular interpolation of the finish point should be set by a signed 32-bit format with the data length of 4 bytes, although its calculatable data range is from -8,388,608 to +8,388,607 signed 24-bit format.

The contents of WR6 and WR7 are unknown while resetting.

B.8 Main Status Register: RR0

This register is used for displaying the driving and error status of each axis. It also displays interpolation driving, ready signal for continuous interpolation, quadrant of circular interpolation and stack counter of bit pattern interpolation.

D15	D14	D13	D12 ^H	D11	D10	D9	D8	D7	D6	D5	D4 ^L	D3	D2	D1	D0
-	BPSC1	BPSC0	ZONE2	ZONE1	ZONED	CNEXT	I-DRV	0	0	Y-ERR	X-ERR	0	0	Y-DRV	X-DRV
								Error Status of Each Axis				Driving Status of Each Axis			

D1, 0 n-DRV Displaying driving status of each axis When the bit is 1, the axis is an outputting drive pulse. ; when the bit is 0, the driving of the axis is finished. Once the in-position input signal nINPOS for servomotor is active, nINPOS will return to 0 after the drive pulse output is finished.

D5, 4 n-ERR Displaying error status of each axis If any of the error bits (D6~D0) of each axis's RR2 register and any of the error-finish bits (D15~D12) of each axis' s RR1 register becomes 1, this bit will become 1.

D8 I-DRV Displaying interpolation driving status While the interpolation drive pulses are outputting, the bit is 1.

D9 CNEXT Displaying the possibility of continuous interpolation data writing When the bit is 1, it is ready for inputting parameters for next node and also ready for writing interpolation command data.

D12 ~ 10 ZONEm Displaying the quadrant of the current position in circular interpolation

D12	D11	D10	Quadrant
0	0	0	0
0	0	1	1
0	1	0	2
0	1	1	3
1	0	0	4
1	0	1	5
1	1	0	6
1	1	1	7

D14,13 BPSC1,0 In bit pattern interpolation driving, it displays the value of the stack counter (SC).

D14	D13	Stack Counter (SC) Value
0	0	0
0	1	1
1	0	2
1	1	3

In bit pattern interpolation driving, when SC = 3, it shows the stack is full. When SC = 2, there is one word (16-bit) space for each axis. When SC = 1, there is a 2-word (16-bit × 2) for each axis. When SC = 0, it shows all the stacks are empty, and the bit-pattern interpolation is finished.

B.9 Status Register 1: RR1

Each axis is with status register 1. The axis specified by NOP command or the condition before decides which axis' s register will be read.

The register can display the comparison result between logical / real position counter and COMP +/- , the acceleration status of acceleration / deceleration driving, jerk of S-curve acceleration / deceleration and the status of driving finishing.

D15	D14	D13	D12 ^H	D11	D10	D9	D8	D7	D6	D5	D4 ^L	D3	D2	D1	D0
EMG	ALARM	LMT-	LMT+	—	STOP2	STOP1	STOP0	ADSND	ACNST	AASND	DSND	CNST	ASND	CMP-	CMP+

Status of Driving Finishing

- D0 CMP+** Displaying the comparison result between logical / real position counter and **COMP+** register
1: logical / real position counter \geq **COMP+** register
0: logical / real position counter $<$ **COMP+** register
- D1 CMP-** Displaying the comparison result between logical / real position counter and **COMP-** register
1: logical / real position counter $<$ **COMP-** register
0: logical / real position counter \geq **COMP-** register
- D2 ASND** It becomes 1 when in acceleration.
- D3 CNST** It becomes 1 when in constant speed driving.
- D4 DSND** It becomes 1 when in deceleration.
- D5 AASND** In S-curve, it becomes 1 when acceleration / deceleration increases.
- D6 ACNST** In S-curve, it becomes 1 when acceleration / deceleration keeps constant speed.
- D7 ADSND** In S-curve, it becomes 1 when acceleration / deceleration decreases.
- D10~8 STOP2~0** If the driving is stopped by one of external decelerating stop signals (nSTOP2 ~ 0), it will become 1.
- D12 LMT+** If the driving is stopped by +direction limit signal (nLMTP), it will become 1.
- D13 LMT-** If the driving is stopped by -direction limit signal (nLMTM), it will become 1.
- D14 ALARM** If the driving is stopped by nALARM from servo drivers, it will become 1.
- D15 EMG** If the driving is stopped by external emergency signal (EMGN), it will become 1.

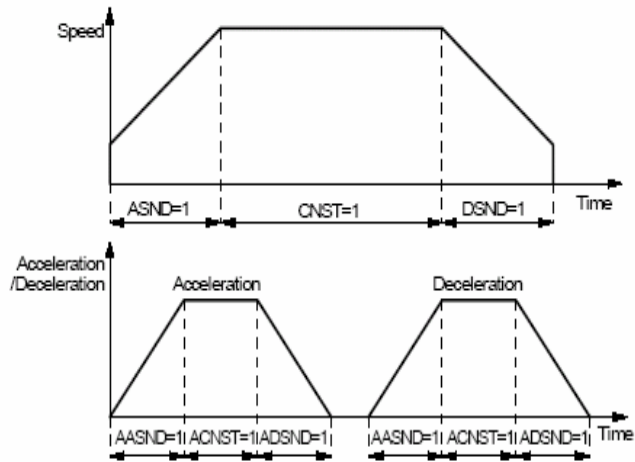

The Status Bits of Driving Finishing

These bits are keeping the factor information of driving finishing. The factors for driving finishing in fixed driving and continuous driving are shown as follows:

- a. when all the drive pulses are output in fixed driving,
- b. when deceleration stop or sudden stop command is written,
- c. when software limit is enabled, and is active,
- d. when external deceleration signal is enabled, and active,
- e. when external limit switch signals (nLMTP, nLMTM) become active,
- f. when nALARM signal is enabled, and active, and
- g. when EMGN signal is on the Low level.

Above factors “a.” and “b.” can be controlled by the host CPU, and factor “c.” can be confirmed by register RR2 even the driving is finished. As for factors “d.” ~ “g.”, the error status is latched in RR2 until next driving command or a clear command (25h) is written.

After the driving is finished, if the error factor bits D15~D12 become 1, n-ERR bit of main status register RRO will become 1.

Status bit of driving finishing can be cleared when next driving command is written, or when the finishing status clear command (25h) is used.

B.10 Status Register 2: RR2

Each axis is with status register 2. The axis specified by NOP command or the condition before decides which axis' s register will be read.

This register is for reflecting the error information. When an error occurs, the error information bit is set to 1. When one or more of D6 to D0 bits of RR2 register are 1, n-ERR bits of main status register RR0 become 1.

RR2

D15	D14	D13	D12 ^H	D11	D10	D9	D8	D7	D6	D5	D4 ^L	D3	D2	D1	D0
-	-	-	-	-	-	-	-	-	MULT	EMG	ALARM	HLMT-	HLMT+	SLMT-	SLMT+

D0 SLMT+ During the + direction driving, when logical / real position counter \geq COMP+ (COMP+ enabled, and used as software limit)

D1 SLMT- During the - direction driving, when logical / real position counter \leq COMP- (COMP- enabled, and used as software limit)

D2 HLMT+ When external +direction limit signal (nLMTP) is on its active level

D3 HLMT- When external -direction limit signal (nLMTM) is on its active level

D4 ALARM When the alarm signal (nALARM) for servo motor is on its active level

D5 EMG When emergency stop signal (EMGN) becomes Low level.

D6 MULT This bit is only for the X axis of main chip at the multichip interpolation. When an error occurs in any axis of sub chip during multichip interpolation, it will become 1.

In driving, when hardware / software limit is active, the decelerating

stop or sudden stop will be executed. Bit SLMT+ / - will not become 1 during the reverse direction driving.

B.11 Status Register 3: RR3

Each axis is with status register 3. The axis specified by NOP command or the condition before decides which axis' s register will be read.

This register is for reflecting the interrupt factor. When interrupt happens, the bit with the interrupt factor becomes 1. The user should set the interrupt factor through register WR1 to perform the interrupt.

To generate an interrupt, interrupt enable must be set for each factor in the WR1 register.

RR3

H								L							
D15	D14	D13	D12	D11	D10	D9	D8	D7	D6	D5	D4	D3	D2	D1	D0
—	—	—	—	—	—	—	—	D-END	C-STA	C-END	P≥C+	P<C+	P<C-	P≥C-	—

D1 P ≥ C- Once the value of logical / real position counter is larger than that of COMP- register D2 P < C- Once the value of logical / real position counter is smaller than that of COMP- register D3 P < C+ Once the value of logical / real position counter is smaller than that of COMP+ register D4 P ≥ C+ Once the value of logical / real position counter is larger than that of COMP+ register D5 C-END When the pulse output is finished in the constant speed drive during an acceleration / deceleration driving D6 C-STA When the pulse output is started in the constant speed drive during an acceleration / deceleration driving D7 D-END When the driving is finished When one of the interrupt factors occurs an interrupt, the bit of the register becomes 1, and the interrupt output signal (INTN) will become the Low level. The host CPU will read register RR3 of the interrupted axis, the bit of RR3 will be cleared to 0, and the interrupt signal will return to the non-active level. For a 8-bit data bus, all the bits are cleared when the RR3L register is read.

B.12 Input Register: RR4 / RR5

RR4 and RR5 are used for displaying the input signal status. The bit is 0 if the input is on the Low level; the bit is 1 if the input is on the Hi level. These input signals can be used as general input signal when they are not used as function except for nLMTP/M signal.

RR4

D15	D14	D13	D12	H				D7	D6	D5	D4	L			
X-LM	X-LM+	X-IN5	X-IN4	X-IN3	X-IN2	X-IN1	X-IN0	X-ALM	X-INP	X-EX-	X-EX+	ENG	X-ST2	X-ST1	X-ST0

RR5

D15	D14	D13	D12	H				D7	D6	D5	D4	L			
Y-LM	Y-LM+	Y-IN5	Y-IN4	Y-IN3	Y-IN2	Y-IN1	Y-IN0	Y-ALM	Y-INP	Y-EX-	Y-EX+	—	Y-ST2	Y-ST1	Y-ST0

Bit Name	Input Signal	Bit Name	Input Signal
n-ST0	n-STOP0	n-IN0	nIN0
n-ST1	n-STOP1	n-IN1	nIN1
n-ST2	n-STOP2	n-IN2	nIN2
EMG	EMGN	n-IN3	nIN3
n-EX+	nEXPP	n-IN4	nIN4
n-EX-	nEXPM	n-IN5	nIN5
n-INP	nINPOS	n-LM+	nLMTP
n-ALM	nALARM	n-LM-	nLMTM

B.13 Data-Read Register: RR6 / RR7

According to the data-read command, the data of internal registers will be set into registers RR6 and RR7. The low word 16 bits (D15 ~ D0) is set in RR6 register, and the high word 16 bits (D31 ~ D16) is set in RR7 register for data reading.

RR6

D15	D14	D13	D12	H				D7	D6	D5	D4	L			
RD15	RD14	RD13	RD12	RD11	RD10	RD9	RD8	RD7	RD6	RD5	RD4	RD3	RD2	RD1	RD0

RR7

D15	D14	D13	D12	H				D7	D6	D5	D4	L			
RD31	RD30	RD29	RD28	RD27	RD26	RD25	RD24	RD23	RD22	RD21	RD20	RD19	RD18	RD17	RD16

The data is binary formatted; 2' s complement is for negatives.