

PISO-725

User's Manual

Warranty

All products manufactured by ICP DAS are warranted against defective materials for a period of one year from the date of delivery to the original purchaser.

Warning

ICP DAS assume no liability for damages consequent to the use of this product. ICP DAS reserves the right to change this manual at any time without notice. The information furnished by ICP DAS is believed to be accurate and reliable. However, no responsibility is assumed by ICP DAS for its use, nor for any infringements of patents or other rights of third parties resulting from its use.

Copyright

Copyright 2000 by ICP DAS. All rights are reserved.

Trademark

The names used for identification only may be registered trademarks of their respective companies.

Tables of Contents

1. INTRODUCTION	2
1.1 FEATURES	2
1.2 SPECIFICATIONS	3
1.3 ORDER DESCRIPTION.....	3
1.3.1 Options	3
1.4 PCI DATA ACQUISITION FAMILY	4
1.5 PRODUCT CHECK LIST.....	4
2. HARDWARE CONFIGURATION	5
2.1 BOARD LAYOUT	5
2.2 I/O OPERATION	7
2.2.1 Isolated/Non-isolated Digital Input.....	7
2.2.2 Isolated Digital Input.....	8
2.2.3 Non-isolated Digital Input.....	9
2.2.4 Digital Output Architecture.....	10
2.3 INTERRUPT OPERATION	11
2.3.1 Interrupt Block Diagram of PISO-725	12
2.3.2 INT_CHAN_0.....	13
2.3.3 INT_CHAN_1	14
2.3.4 INT_CHAN_2 to INT_CHAN_7.....	15
2.3.5 Initial_high, active_low Interrupt source	16
2.3.6 Initial_low, active_high Interrupt source	17
2.3.7 Multiple Interrupt Source 1	18
2.3.8 Multiple Interrupt Source 2	19
2.4 DAUGHTER BOARDS.....	20
2.4.1 DB-37	20
2.4.2 DN-37	20
2.5 PIN ASSIGNMENT.....	21
2.5.1 I/O connector.....	21
3. I/O CONTROL REGISTER	22
3.1 HOW TO FIND THE I/O ADDRESS	22
3.1.1 PIO_DriverInit	23
3.1.2 PIO_GetConfigAddressSpace.....	24
3.1.3 Show_PIO_PISO	25
3.2 THE ASSIGNMENT OF I/O ADDRESS	26
3.3 THE I/O ADDRESS MAP.....	27
3.3.1 RESET\ Control Register.....	27
3.3.2 AUX Control Register.....	27
3.3.3 AUX data Register.....	28
3.3.4 INT Mask Control Register.....	28
3.3.5 Aux Status Register.....	28
3.3.6 Interrupt Polarity Control Register.....	29
3.3.7 I/O Data Register.....	29
4. DEMO PROGRAM	30
4.1 PIO_PISO	31
4.1.1 PIO_PISO.EXE for Windows	32
4.2 DEMO1: D/O DEMO	33
4.3 DEMO2: D/I/O DEMO	35
4.4 DEMO3: INIT_HIGH, ACTIVE_LOW	36
4.5 DEMO4: INIT_LOW, ACTIVE_HIGH	38
4.6 DEMO5: 2-CHANNEL INTERRUPT.....	40
4.7 DEMO6: 8-CHANNEL INTERRUPT.....	42

1. Introduction

The PISO-725 is a 16-channels of digital input/output interface board for the PCI bus computers. The PISO-725 provides 8-channel of electromechanical relays and 8-channel of isolated/non-isolated digital input. The PISO-725 can be used in various applications including contact closure, external voltage sensing, and loading sensing and designed for control and sensing applications.

The PISO-725 has one 37-pin D-Type connector. It can be installed in a 5V PCI slot and can support truly “Plug & Play”.

1.1 Features

Features for D/I:

- State-changed interrupt for all digital inputs
- 8-channel of digital inputs
- Digital input can be isolated or non-isolated selected by hardware jumper

Features for D/O:

- 8-channel of electromechanical relays
- Two Form-C relay
- One Form-C for user's external device: COM, NC, NO
- The other Form-C for relay status read back
- Output states indicative LEDs

Others:

- PCI Bus
- One 37-pin D-type connector for input and output
- SMD, short card, power saving
- Automatically detected by Windows 95/98/2000/XP

1.2 Specifications

General specifications

- Operation Temp: 0-60°C
- Storage Temp: -20°C to 70°C
- Humidity: 0-90%, non-condensing
- Dimensions: 150mm×110mm
- Power consumption: 300mA@5V, typical

Input

- Channel No.: 8
- Isolated/Non-isolated input selected by jumper JA&JB
- Photo-coupler for isolated input: PC-357
- Input_high voltage for isolated input: 3.5 ~ 30V
- Input_low voltage for isolated input: 0 ~ 1V
- Input impedance for isolated input: 1.2K, 1W
- Isolation voltage for isolated input: 3750V
- Response time for isolated input: 20uS
- Non-isolated input: TTL compatible

Output

- Channel: 8
- Two Form-C relay: COM, NC & NO(the other Form-C for read back)
- Contact rating: AC: 0.3A/120VAC
DC: 1A/30VDC
- Operating time: 5ms
- Release time: 10ms
Life: 100,000 times (at 30V/1A)

1.3 Order Description

- PISO-725: 8 channels isolated digital input, 8 channels relay output board

1.3.1 Options

- DN-37: I/O connector block with DIN-Rail mounting and 37-pin D-type connector
- DB-37: 37-pin D-type connector pin to pin screw terminal for any 37 pin D-type connector of I/O board

1.4 PCI Data Acquisition Family

We provide a family of PCI-BUS data acquisition cards. These cards can be divided into three groups as following:

1. **PCI-series: first generation, isolated or non-isolated cards**
PCI-1002/1202/1800/1802/1602: multi-function family, non-isolated
PCI-P16R16/P16C16/P16POR16/P8R8: D/I/O family, isolated
PCI-TMC12: timer/counter card, non-isolated
2. **PIO-series: cost-effective generation, non-isolated cards**
PIO-823/821: multi-function family
PIO-D144/D96/D64/D56/D48/D24: D/I/O family
PIO-DA16/DA8/DA4: D/A family
3. **PISO-series: cost-effective generation, isolated cards**
PISO-813: A/D card
PISO-P32C32/P64/C64: D/I/O family
PISO-P8R8/P8SSR8AC/P8SSR8DC: D/I/O family
PISO-730: D/I/O card
PISO-725: D/I/O card
PISO-DA2: D/A card

1.5 Product Check List

In addition to this manual, the package includes the following items:

- one piece of PISO-725 card
- one piece of company floppy diskette or CD
- one piece of release note

It is recommended to read the release note firstly. All importance information will be given in release note as following:

1. where you can find the software driver & utility
2. how to install software & utility
3. where is the diagnostic program
4. FAQ

Attention!

If any of these items is missing or damaged, contact the dealer from whom you purchased the product. Save the shipping materials and carton in case you want to ship or store the product in the future.

2. Hardware configuration

2.1 Board Layout

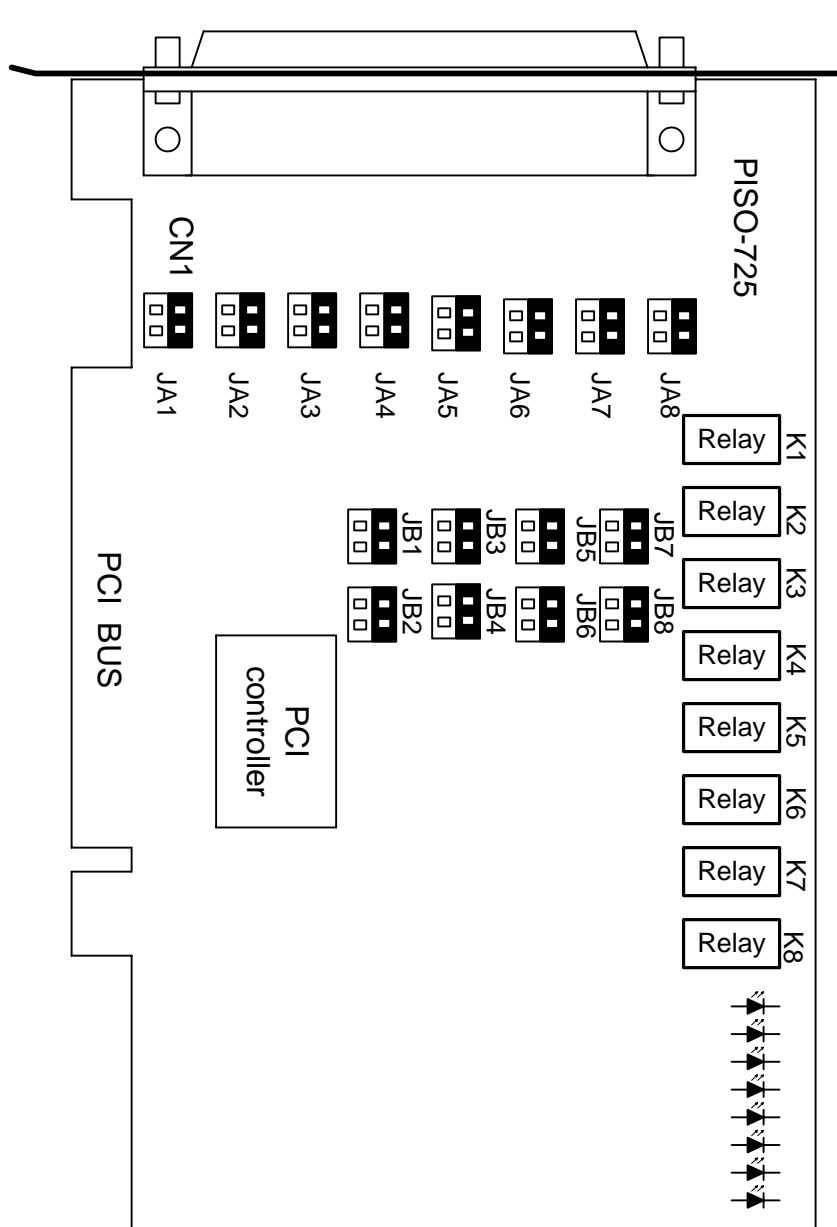

- (JA?,JB?) is used to select the isolated/non-isolated digital input.
- The default setting of all (JA?, JB?) = isolated input

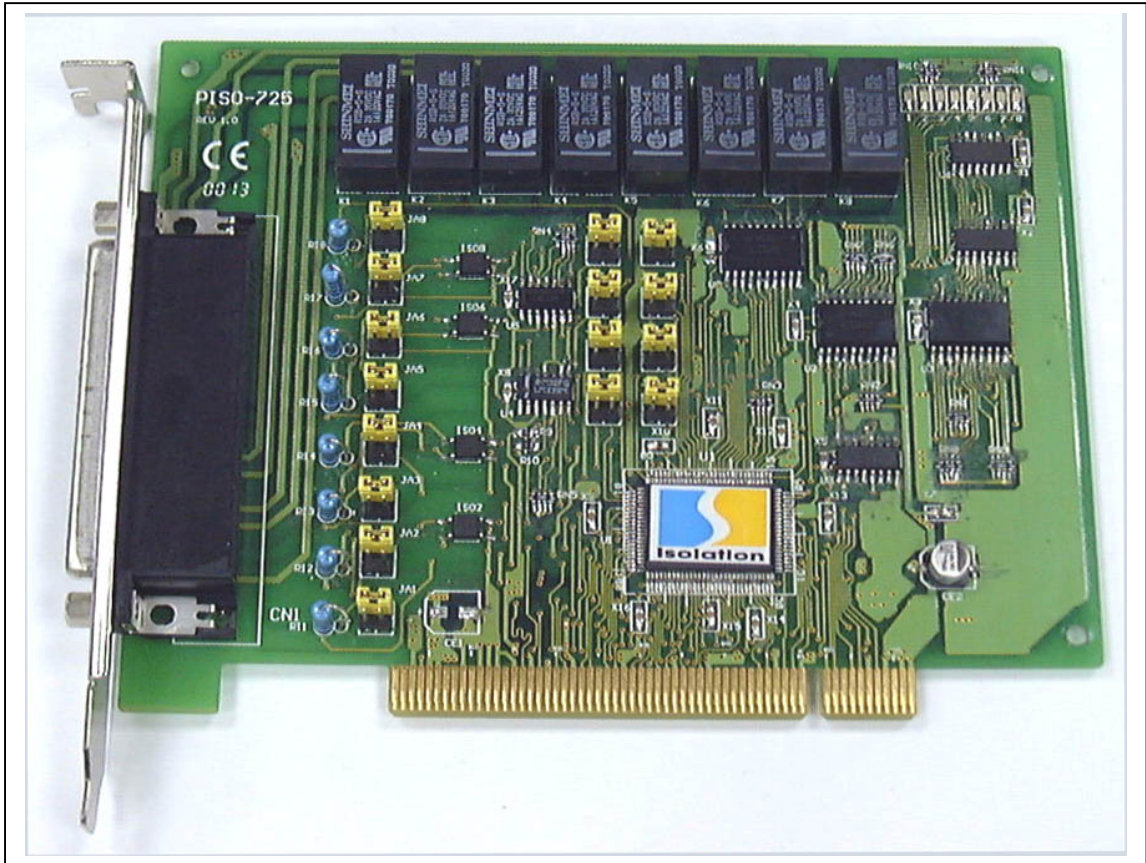

2.2 I/O Operation

2.2.1 Isolated/Non-isolated Digital Input

The PISO-725 provides 8-channel of digital input. These input can be used as isolated or non-isolated based on different jumper setting. The jumper setting for isolated input is given as following:

Channel	Signal Name	Pin Assignment	Jumper
(0+, 0-)	(DIA0,DIB0)	(12,30)	JA1 & JB1
(1+, 1-)	(DIA1,DIB1)	(13,31)	JA2 & JB2
(2+, 2-)	(DIA2,DIB2)	(14,32)	JA3 & JB3
(3+, 3-)	(DIA3,DIB3)	(15,33)	JA4 & JB4
(4+, 4-)	(DIA4,DIB4)	(16,34)	JA5 & JB5
(5+, 5-)	(DIA5,DIB5)	(17,35)	JA6 & JB6
(6+, 6-)	(DIA6,DIB6)	(18,36)	JA7 & JB7
(7+, 7-)	(DIA7,DIB7)	(19,37)	JA8 & JB8

The block diagram of JA, JB & digital input circuit.

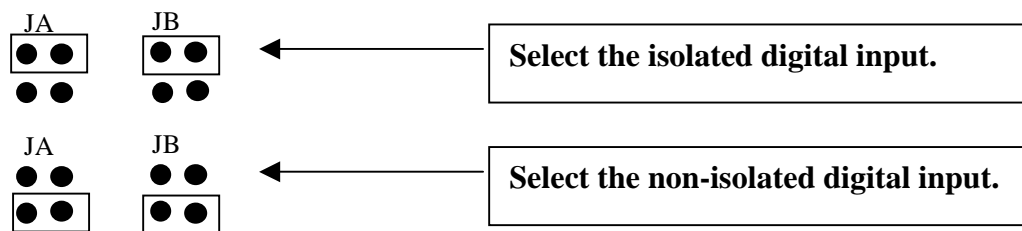
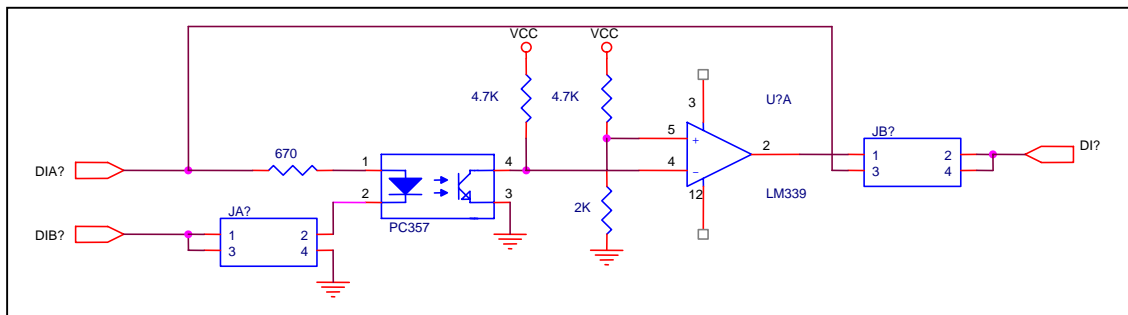

2.2.2 Isolated Digital Input

Refer to Sec. 2.2.1 for more information.

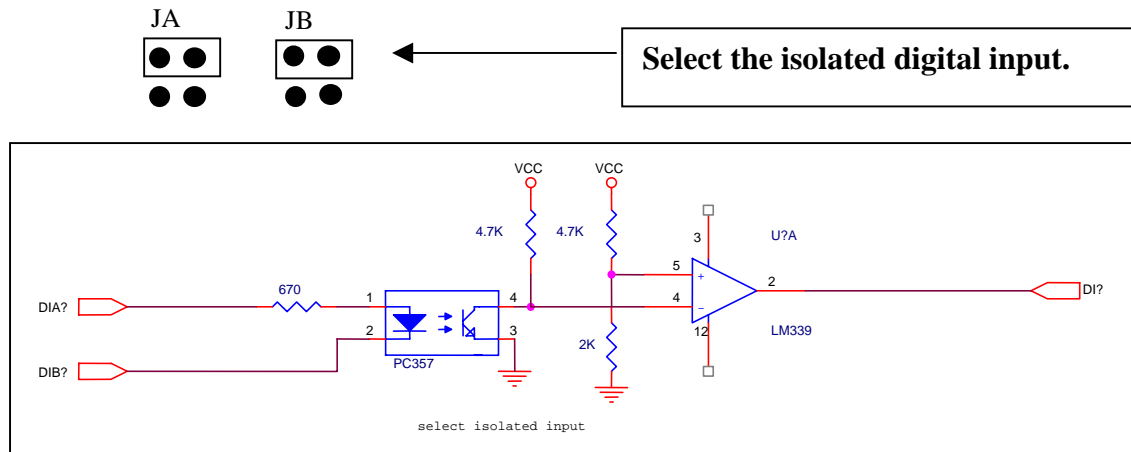

The features of isolated input are given as following:

- Photo-coupler for isolated input: PC-357
- Input_high voltage for isolated input: 3.5 ~ 30V
- Input_low voltage for isolated input: 0 ~ 1V
- Input impedance for isolated input: 3K, 1/2W
- Isolation voltage for isolated input: 3750V
- Response time for isolated input: 20uS

The (DIA? & DIB?) is used as a differential input (In+, In-) as following:

Channel	Signal Name	Pin Assignment	Jumper
(0+, 0-)	(DIA0,DIB0)	(12,30)	JA1 & JB1
(1+, 1-)	(DIA1,DIB1)	(13,31)	JA2 & JB2
(2+, 2-)	(DIA2,DIB2)	(14,32)	JA3 & JB3
(3+, 3-)	(DIA3,DIB3)	(15,33)	JA4 & JB4
(4+, 4-)	(DIA4,DIB4)	(16,34)	JA5 & JB5
(5+, 5-)	(DIA5,DIB5)	(17,35)	JA6 & JB6
(6+, 6-)	(DIA6,DIB6)	(18,36)	JA7 & JB7
(7+, 7-)	(DIA7,DIB7)	(19,37)	JA8 & JB8

If all input pins are floating, all DI? will be equal to 1.

2.2.3 Non-isolated Digital Input

Refer to Sec. 2.2.1 for more information.

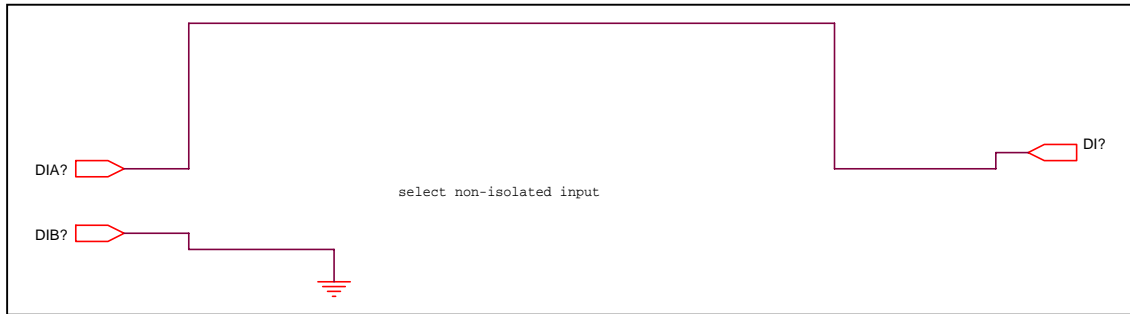
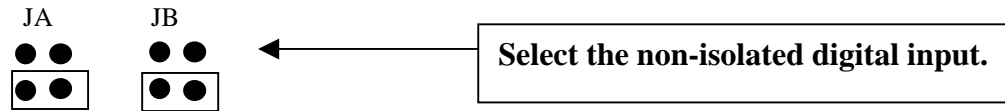

The non-isolated input is TTL compatible.

All DIB? are connected to GND. All DIA? Are used as a single-ended input as following:

Channel	Signal Name	Pin Assignment	Jumper
0+	DIA0	12	JA1 & JB1
1+	DIA1	13	JA2 & JB2
2+	DIA2	14	JA3 & JB3
3+	DIA3	15	JA4 & JB4
4+	DIA4	16	JA5 & JB5
5+	DIA5	17	JA6 & JB6
6+	DIA6	18	JA7 & JB7
7+	DIA7	19	JA8 & JB8
GND	DIB0 to DIB 7	30 to 37	All DB?=GND

If all input pins are float, all DI? will be equal to 1.

2.2.4 Digital Output Architecture

When the PC is power-up, all states of output relay are “open”. The enable/disable of output operation is controlled by the RESET\ signal. Refer to Sec. 3.3.1 for more information about RESET\ signal.

- The RESET\ is in Low-state → all output operation are disable
- The RESET\ is in High-state → all output operation are enable

The block diagram of isolated output is given as following:

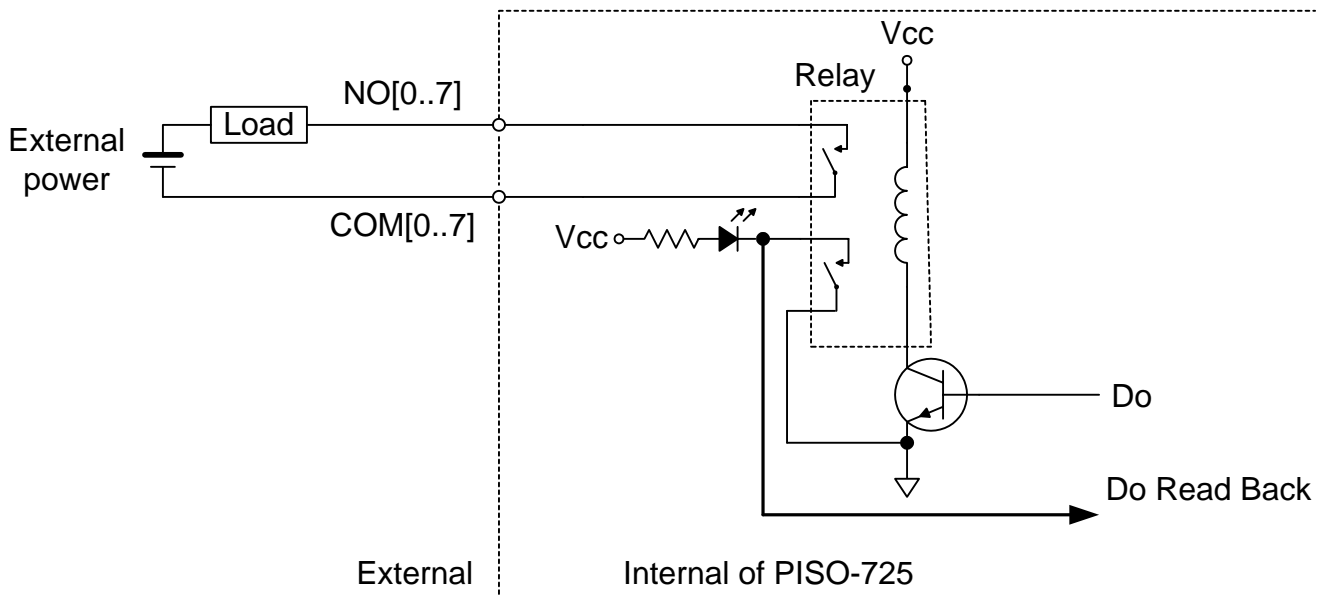

The relay of PISO-725 is 2-Form-C type as following:

One Form-C for user's external device:

- COM: common input of relay
- NO: normal open output (this pin will OPEN from COM after power-up)
- NC: normal close output (this pin will CLOSE to COM after power-up)

The other form-C for read back (refer to Sec. 3.3.7 for more information)

2.3 Interrupt Operation

There are 8 interrupt sources in PISO-725. These 8 signals are named as INT_CHAN_0, INT_CHAN_1,, & INT_CHAN_7 as following:

INT_CHAN_0: (DIA0, DIB0)
INT_CHAN_1: (DIA1, DIB1)
INT_CHAN_2: (DIA2, DIB2)
INT_CHAN_3: (DIA3, DIB3)
INT_CHAN_4: (DIA4, DIB4)
INT_CHAN_5: (DIA5, DIB5)
INT_CHAN_6: (DIA6, DIB6)
INT_CHAN_7: (DIA7, DIB7)

If only one interrupt signal source is used, the interrupt service routine does not have to identify the interrupt source. Refer to DEMO3.C and DEMO4.C for more information.

If there are more than one interrupt source, the interrupt service routine has to identify & service all active signals as following: (refer to DEMO5.C & DEMO6.C)

1. **Read the new status of all interrupt signal sources(refer to Sec 3.3.5)**
2. **Compare the new status with the old status to identify the active signals**
3. **If INT_CHAN_0 is active, service it**
4. **If INT_CHAN_1 is active, service it**
5. **If INT_CHAN_2 is active, service it**
6. **If INT_CHAN_3 is active, service it**
7. **If INT_CHAN_4 is active, service it**
8. **If INT_CHAN_5 is active, service it**
9. **If INT_CHAN_6 is active, service it**
10. **If INT_CHAN_7 is active, service it**
11. **Update interrupt status**

Note: if the interrupt signal is too short, the new status may be as same as old status. In that condition the interrupt service routine can not identify which interrupt source is active. So the interrupt signal must be hold_active long enough until the interrupt service routine is executed. This hold_time is different for different O.S. The hold_time can be as short as micro-second or as long as second. In general, 20ms is enough for all O. S.

Refer to the following sections for more information:

Sec. 4.4 DEMO3.C

Sec. 4.5 DEMO4.C

Sec. 4.6 DEMO5.C

Sec. 4.7 DEMO6.C

2.3.1 Interrupt Block Diagram of PISO-725

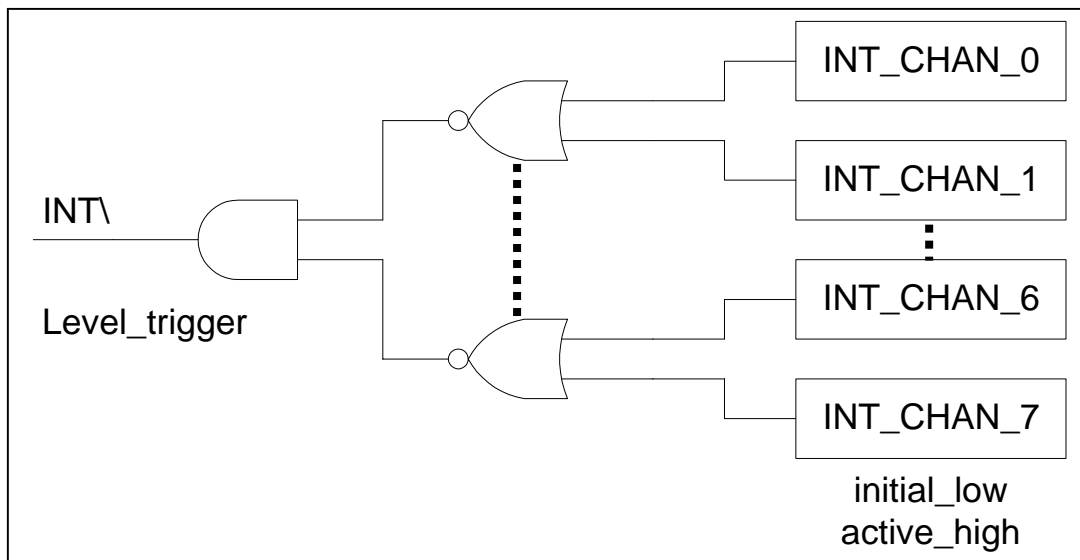

The interrupt output signal of PISO-725, INT\ is **level-trigger & Active_Low**. If the INT\ generate a low-pulse, the PISO-725 will interrupt the PC once a time. If the INT\ is fixed in low level, the PISO-725 will interrupt the PC continuously. So the INT_CHAN_0/1/2/3/4/5/6/7 must be controlled in a **pulse_type** signals. **They must be fixed in low level state normally and generated a high_pulse to interrupt the PC.**

The priority of INT_CHAN_0/1/2/3/4/5/6/7 is the same. If all these 8 signals are active at the same time, then INT\ will be active only once a time. So the interrupt service routine has to read the status of all interrupt channels for multi-channel interrupt. Refer to DEMO5.C & DEMO6.C for more information.

DEMO5.C → for 2-channel interrupt source
DEMO6.C → for 8-channel interrupt source

If only one interrupt source is used, the interrupt service routine doesn't have to read the status of interrupt source. The demo program DEMO3.C and DEMO4.C are designed for single-channel interrupt demo.

DEMO3.C & DEMO4.C → for INT_CHAN_0 only

2.3.2 INT_CHAN_0

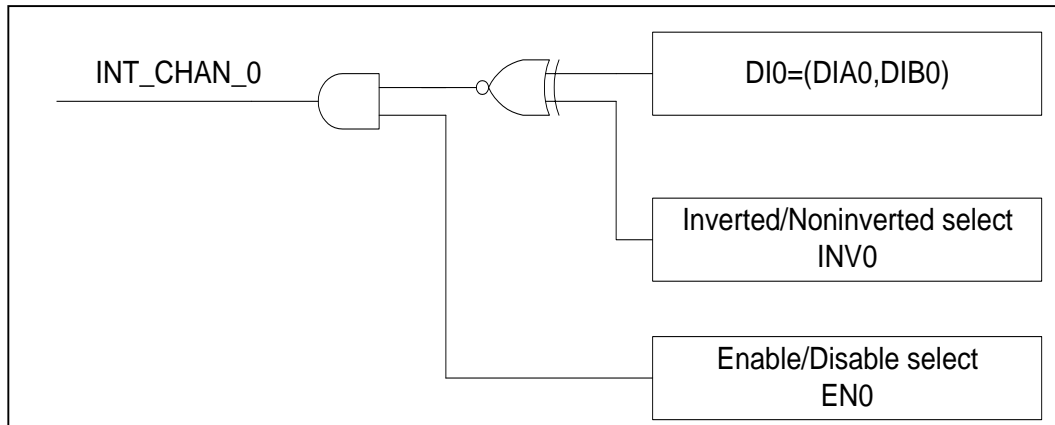

The INT_CHAN_0 must be fixed in low level state normally and generated a high_pulse to interrupt the PC.

The EN0 can be used to enable/disable the INT_CHAN_0 as following: (refer to Sec. 3.3.4)

EN0=0 → INT_CHAN_0=disable

EN0=1 → INT_CHAN_0=enable

The INV0 can be used to invert/non-invert the DIO as following: (Refer to Sec. 3.3.6)

INV0=0 → INT_CHAN_0=invert state of DIO

INV0=1 → INT_CHAN_0=non-invert state of DIO

Refer to demo program for more information as following:

DEMO3.C → for INT_CHAN_0 (initial high)

DEMO4.C → for INT_CHAN_0 (initial low)

DEMO5.C → for 2-channel interrupt source

DEMO6.C → for 8-channel interrupt source

NOTE: Refer to Sec. 2.3.5 & Sec. 2.3.6 for active high-pulse generation.

2.3.3 INT_CHAN_1

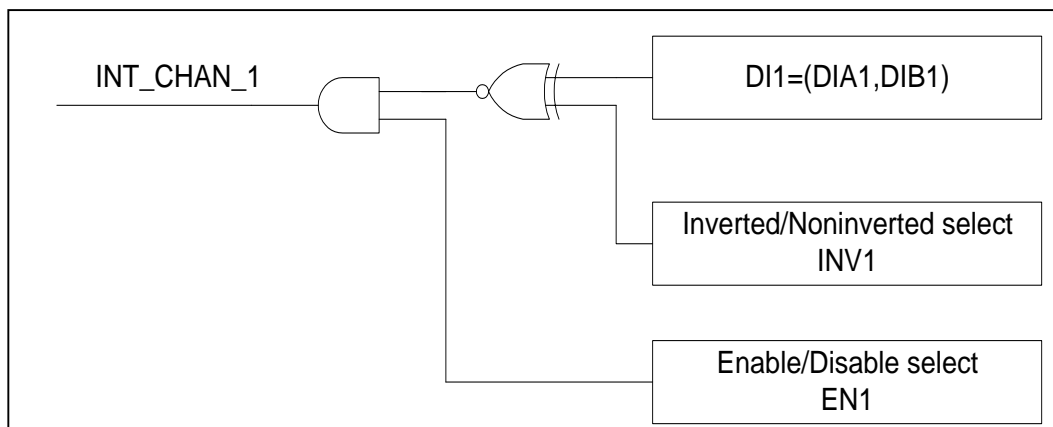

The INT_CHAN_1 must be fixed in low level state normally and generated a high_pulse to interrupt the PC.

The EN1 can be used to enable/disable the INT_CHAN_1 as following: (refer to Sec. 3.3.4)

EN1=0→INT_CHAN_1=disable

EN1=1→INT_CHAN_1=enable

The INV1 can be used to invert/non-invert the DI1 as following: (Refer to Sec. 3.3.6)

INV1=0→INT_CHAN_1=invert state of DI1

INV1=1→INT_CHAN_1=non-invert state of DI1

Refer to demo program for more information as following:

DEMO3.C → for INT_CHAN_0 (initial high)

DEMO4.C → for INT_CHAN_0 (initial low)

DEMO5.C → for 2-channel interrupt source

DEMO6.C → for 8-channel interrupt source

NOTE: Refer to Sec. 2.3.5 & Sec. 2.3.6 for active high-pulse generation.

2.3.4 INT_CHAN_2 to INT_CHAN_7

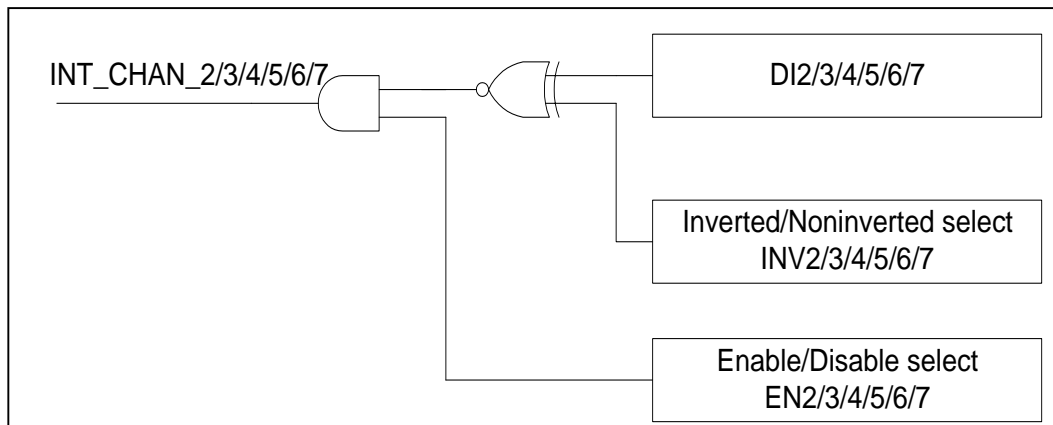

The INT_CHAN_2/3/4/5/6/7 must be fixed in low level state normally and generated a high_pulse to interrupt the PC.

The EN2 to EN7 can be used to enable/disable the INT_CHAN_2 to INT_CHAN_7 as following: (refer to Sec. 3.3.4)
EN2 to EN7=0→INT_CHAN_2 to INT_CHAN_7=disable
EN2 to EN7=1→INT_CHAN_2 to INT_CHAN_7=enable

The INV2 to INV7 can be used to invert/non-invert the DI2 to DI7 as following:
(Refer to Sec. 3.3.6)
INV2 to INV7=0→INT_CHAN_2 to INT_CHAN_7=invert state of DI2 to DI7
INV2 to INV7=1→INT_CHAN_2 to INT_CHAN_7=non-invert state of DI2 to DI7

Refer to demo program for more information as following:

DEMO3.C → for INT_CHAN_0 (initial high)
DEMO4.C → for INT_CHAN_0 (initial low)
DEMO5.C → for 2-channel interrupt source
DEMO6.C → for 8-channel interrupt source

NOTE:

1. DI2=(DIA2, DIB2)
2. DI3=(DIA3, DIB3)
3. DI4=(DIA4, DIB4)
4. DI5=(DIA5, DIB5)
5. DI6=(DIA6, DIB6)
6. DI7=(DIA7, DIB7)
7. Refer to Sec. 2.3.5 & Sec. 2.3.6 for active high-pulse generation.

2.3.5 Initial_high, active_low Interrupt source

If the DIO is an initial_high, active_low signal, the interrupt service routine should use INV0 to invert/non-invert the DIO for high_pulse generation as following: (Refer to DEMO3.C and the DI1/2/3/4/5/6/7 are similar.)

Initial set:

```
now_int_state=1;          /* initial state for DIO */
outportb(wBase+0x2a,0);  /* select the inverted DIO */
```

```
void interrupt irq_service()
{
if (now_int_state==1)      /* now DIO is changed to LOW          */(a)
{
    /* --> INT_CHAN_0=!DIO=HIGH now          */
    COUNT_L++;            /* find a LOW_pulse (DIO)          */
    If((inport(wBase+7)&1)==0)/* the DIO is still fixed in LOW    */
    {
        /* → need to generate a high_pulse */
        outportb(wBase+0x2a,1);/* INV0 select the non-inverted input */(b)
        /* INT_CHAN_0=DIO=LOW -->          */
        /* INT_CHAN_0 generate a high_pulse */
        now_int_state=0;    /* now DIO=LOW                    */
    }
    else now_int_state=1;  /* now DIO=HIGH                    */
        /* don't have to generate high_pulse */
}
else
    /* now DIO is changed to HIGH          */(c)
    {
        /* --> INT_CHAN_0=DIO=HIGH now          */
        COUNT_H++;        /* find a HIGH_pulse (DIO)        */
        If((inport(wBase+7)&1)==1)/* the DIO is still fixed in HIGH  */
        {
            /* need to generate a high_pulse */
            outportb(wBase+0x2a,0);/* INV0 select the inverted input  */(d)
            /* INT_CHAN_0=!DIO=LOW -->          */
            /* INT_CHAN_0 generate a high_pulse */
            now_int_state=1; /* now DIO=HIGH                    */
        }
        else now_int_state=0; /* now DIO=LOW                    */
            /* don't have to generate high_pulse */
    }
}
if (wIrq>=8) outportb(A2_8259,0x20);
outportb(A1_8259,0x20);
}
```

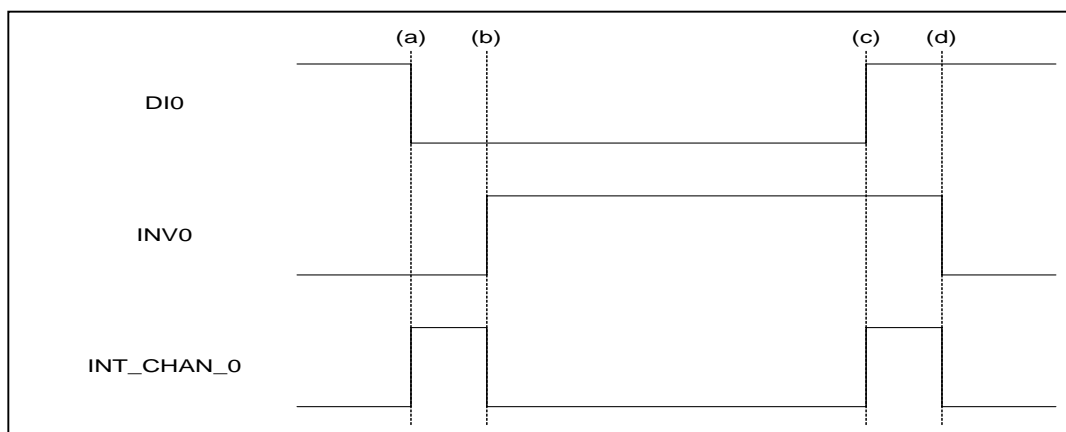

2.3.6 Initial_low, active_high Interrupt source

If the DIO is an initial_low, active_high signal, the interrupt service routine should use INVO to invert/non-invert the DIO for high_pulse generation as following: (Refer to DEMO4.C and the DI1/2/3/4/5/6/7 are similar.)

Initial set:

```
now_int_state=0;          /* initial state for DIO          */
outportb(wBase+0x2a,1);  /* select the non-inverted DIO */
```

```
void interrupt irq_service()
{
if (now_int_state==1)    /* now DIO is changed to LOW          */(c)
{
COUNT_L++;           /* --> INT_CHAN_0=!DIO=HIGH now      */
/* find a LOW_pulse (DIO)          */
If((inport(wBase+7)&1)==0)/* the DIO is still fixed in LOW    */
{
/* → need to generate a high_pulse */
outportb(wBase+0x2a,1);/* INVO select the non-inverted input */(d)
/* INT_CHAN_0=DIO=LOW -->          */
/* INT_CHAN_0 generate a high_pulse */
now_int_state=0;      /* now DIO=LOW                      */
}
else now_int_state=1;  /* now DIO=HIGH                      */
/* don't have to generate high_pulse */
}
else
/* now DIO is changed to HIGH          */(a)
{
/* --> INT_CHAN_0=DIO=HIGH now      */
COUNT_H++;           /* find a High_pulse (DIO)          */
If((inport(wBase+7)&1)==1)/* the DIO is still fixed in HIGH    */
{
/* need to generate a high_pulse    */
outportb(wBase+0x2a,0);/* INVO select the inverted input    */(b)
/* INT_CHAN_0=!DIO=LOW -->          */
/* INT_CHAN_0 generate a high_pulse */
now_int_state=1;      /* now DIO=HIGH                      */
}
else now_int_state=0;  /* now DIO=LOW                      */
/* don't have to generate high_pulse */
}
}
if (wIrq>=8) outportb(A2_8259,0x20);
outportb(A1_8259,0x20);
}
```

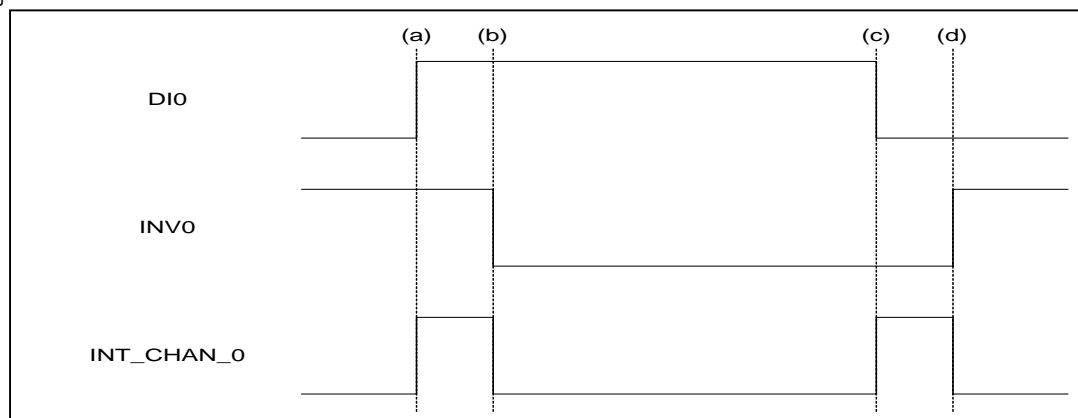

2.3.7 Multiple Interrupt Source 1

Assume: DI0=(DIA0,DIB0) is initial Low, active High
 DI1=(DIA1,DIB1) is initial High, active Low
 as following:

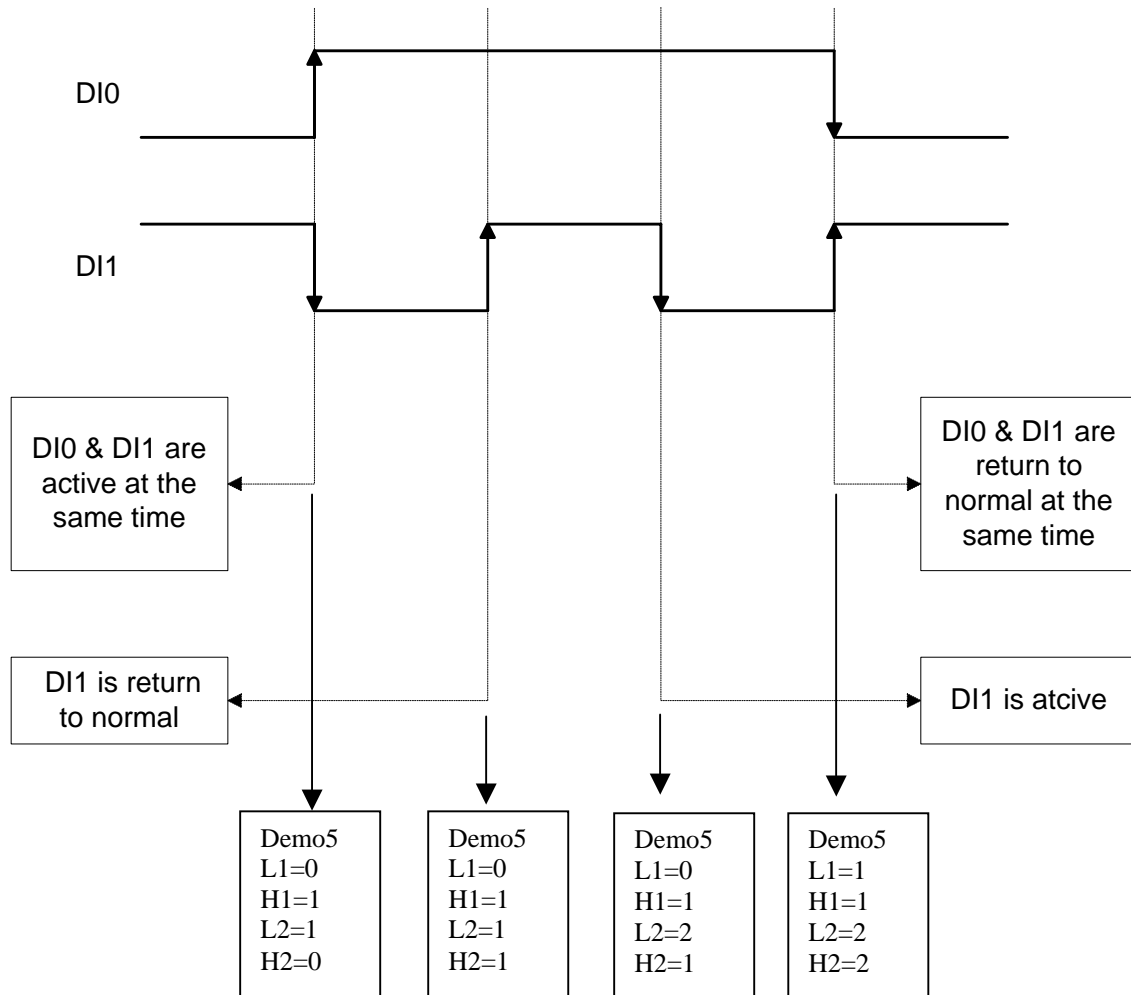

Refer to DEMO5.C for source program. **All these three falling-edge & rising-edge can be detected by DEMO5.C.**

Note: when the interrupt is active, the user program has to identify the active signals. These signals may be active at the same time. So the interrupt service routine has to service all active signals at the same time.

Initial setting:

```
now_int_state=0x2;      /* Initial state: DI0 at low level, DI1 at high level */
invert=0x1;            /* non-invert DI0 & invert DI1 */
outportb(wBase+0x2a,invert);
```

```

void interrupt irq_service()
{
new_int_state=inportb(wBase+7)&0x03; /* read all interrupt state */
int_c=new_int_state^now_int_state; /* compare which interrupt */
/* signal be change */
if ((int_c&0x1)!=0) /* INT_CHAN_0 is active */
{
if ((new_int_state&0x01)!=0) /* now DI0 change to high */
{
CNT_H1++;
}
else /* now DI0 change to low */
{
CNT_L1++;
}
invert=invert^1; /* to generate a high pulse */
}
if ((int_c&0x2)!=0)
{
if ((new_int_state&0x02)!=0) /* now DI1 change to high */
{
CNT_H2++;
}
else /* now DI1 change to low */
{
CNT_L2++;
}
invert=invert^2; /* to generate a high pulse */
}

now_int_state=new_int_state;
outportb(wBase+0x2a,invert);
if (wIrq>=8) outportb(A2_8259,0x20);
outportb(A1_8259,0x20);
}

```

2.3.8 Multiple Interrupt Source 2

Assume: DI0/2/4/5 are initial Low, active High

DI1/3/6/7 are initial High, active Low

Refer to DEMO6.C for state-changed interrupt for all 8 digital inputs.

2.4 Daughter Boards

2.4.1 DB-37

Direct connection board

- 37-pin D-type connector pin to pin screw terminal for any 37-pin D-type connector of I/O board

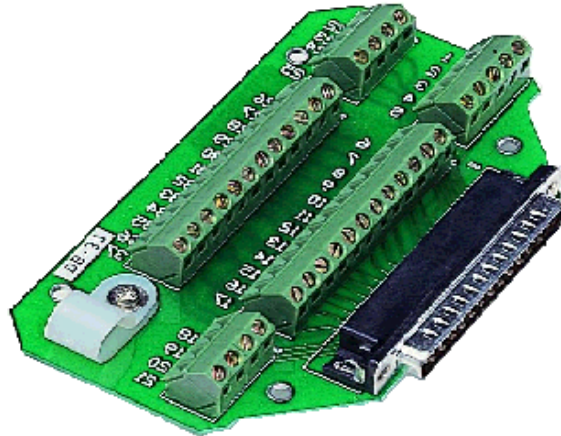

2.4.2 DN-37

I/O connector block with DN-Rail mounting

- Two 37-pin D-type connector (one for extension)
- Pin to pin screw terminal for I/O connector

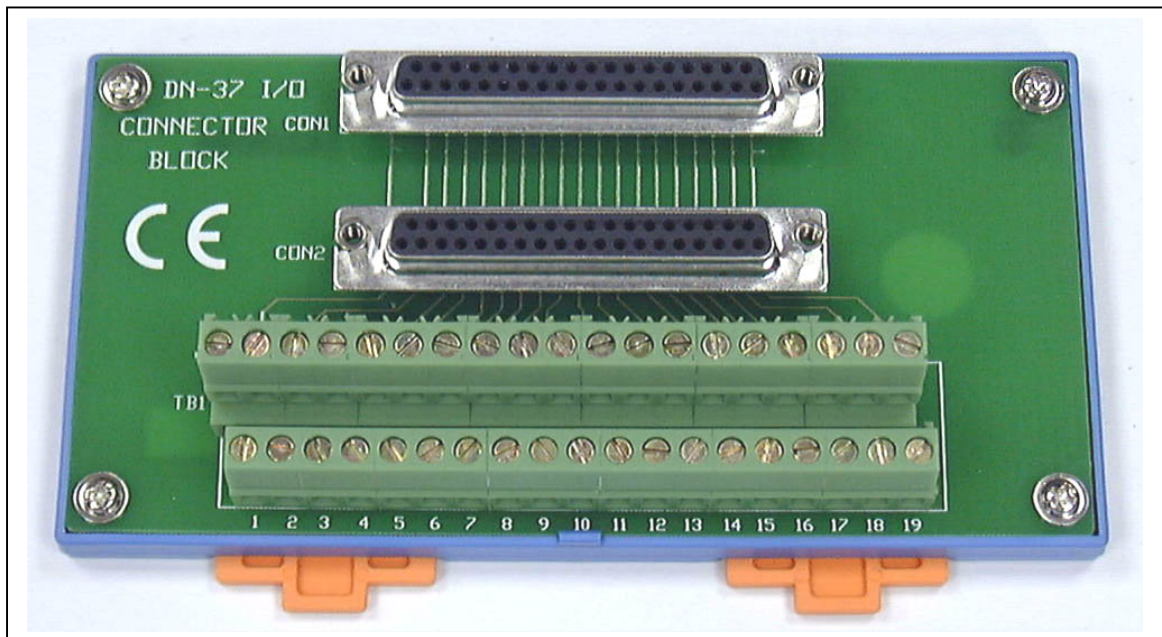

2.5 Pin Assignment

2.5.1 I/O connector

CON1: 37 pin of D-type female connector

Pin No.	Description	Pin No	Description
1	NO0	20	NO3
2	COM0	21	COM3
3	NC0	22	NC3
4	NO1	23	NO4
5	COM1	24	COM4
6	NC1	25	NO5
7	NO2	26	COM5
8	COM2	27	NO6
9	NC2	28	COM6
10	NO7	29	GND
11	COM7	30	DIB0
12	DIA0	31	DIB1
13	DIA1	32	DIB2
14	DIA2	33	DIB3
15	DIA3	34	DIB4
16	DIA4	35	DIB5
17	DIA5	36	DIB6
18	DIA6	37	DIB7
19	DIA7		

Note 1: COM?=Common Point, NO?=Normal Open, NC?=Normal Close

Note 2:

DI0=(DIA0, DIB0)

DI1=(DIA1, DIB1)

DI2=(DIA2, DIB2)

DI3=(DIA3, DIB3)

DI4=(DIA4, DIB4)

DI5=(DIA5, DIB5)

DI6=(DIA6, DIB6)

DI7=(DIA7, DIB7)

Note 3: The DI0 ~ DI7 can be isolated/non-isolated input based on (JA?,JB?) setting. Refer to Sec. 2.2.1 ~ Sec. 2.2.3 for more information.

3. I/O Control Register

3.1 How to Find the I/O Address

The plug & play BIOS will assign a proper I/O address to every PIO/PISO series card in the power-up stage. The fixed IDs of PIO/PISO series card are given as following:

PISO-725

<Rev1.0 ~ 2.0>

- Vendor ID= 0xE159
- Device ID = 0x02
- Sub-Vendor ID= 0x80
- Sub-Device ID= 0x0c
- Sub-Aux ID= 0x00

PISO-725

<Rev3.0>

- Vendor ID= 0xE159
- Device ID= 0x01
- Sub-Vendor ID= 0x0380
- Sub-Device ID= 0x00
- Sub-Aux ID= 0x00

We provide all necessary functions as following:

1. **PIO_DriverInit(&wBoard, wSubVendor, wSubDevice, wSubAux)**
2. **PIO_GetConfigAddressSpace(wBoardNo,*wBase,*wIrq, *wSubVendor, *wSubDevice, *wSubAux, *wSlotBus, *wSlotDevice)**
3. **Show_PIO_PISO(wSubVendor, wSubDevice, wSubAux)**

All functions are defined in PIO.H. Refer to Chapter 4 for more information. The important driver information is given as following:

1. Resource-allocated information:

- wBase : BASE address mapping in this PC
- wIrq: IRQ channel number allocated in this PC

2. PIO/PISO identification information:

- wSubVendor: subVendor ID of this board
- wSubDevice: subDevice ID of this board
- **wSubAux: set this variable to 0xff for PISO-725**

3. PC's physical slot information:

- wSlotBus: hardware slot ID1 in this PC's slot position
- wSlotDevice: hardware slot ID2 in this PC's slot position

The utility program, **PIO_PISO.EXE**, will detect & show all PIO/PISO cards installed in this PC. Refer to Sec. 4.1 for more information.

3.1.1 PIO_DriverInit

PIO_DriverInit(&wBoards, wSubVendor,wSubDevice,wSubAux)

- wBoards=0 to N → number of boards found in this PC
- wSubVendor → subVendor ID of board to find
- wSubDevice → subDevice ID of board to find
- **wSubAux** → **set to 0xff for PISO-725**

This function can detect all PIO/PISO series card in the system. It is implemented based on the PCI plug & play mechanism-1. It will find all PIO/PISO series cards installed in this system & save all their resource in the library.

Sample program 1: find all PISO-725 in this PC

```
wSubVendor=0x80; wSubDevice=0x0C; wSubAux=0xff; /* for PISO-725 */
wRetVal=PIO_DriverInit(&wBoards, wSubVendor,wSubDevice,wSubAux);
printf("Threr are %d PISO-725 Cards in this PC\n",wBoards);
/* step2: save resource of all PISO-725 cards installed in this PC */
for (i=0; i<wBoards; i++)
{
    PIO_GetConfigAddressSpace(i,&wBase,&wIrq,&wID1,&wID2,&wID3,
                              &wID4,&wID5);
    printf("\nCard_%d: wBase=%x, wIrq=%x", i,wBase,wIrq);
    wConfigSpace[i][0]=wBaseAddress; /* save all resource of this card */
    wConfigSpace[i][1]=wIrq; /* save all resource of this card */
}
```

Sample program 2: find all PIO/PISO in this PC(refer to Sec. 4.1 for more information)

```
wRetVal=PIO_DriverInit(&wBoards,0xff,0xff,0xff); /*find all PIO_PISO*/
printf("\nThrer are %d PIO_PISO Cards in this PC",wBoards);
if (wBoards==0 ) exit(0);

printf("\n-----");
for(i=0; i<wBoards; i++)
{
    PIO_GetConfigAddressSpace(i, &wBase, &wIrq, &wSubVendor,
                              &wSubDevice, &wSubAux, &wSlotBus, &wSlotDevice);

    printf("\nCard_%d:wBase=%x,wIrq=%x,subID=[%x,%x,%x],
    SlotID=[%x,%x]", i, wBase, wIrq, wSubVendor, wSubDevice,
    wSubAux, wSlotBus, wSlotDevice);

    printf(" --> ");
    ShowPioPiso(wSubVendor, wSubDevice, wSubAux);
}
```

3.1.2 PIO_GetConfigAddressSpace

**PIO_GetConfigAddressSpace(wBoardNo,*wBase,*wIrq, *wSubVendor,
*wSubDevice, *wSubAux, *wSlotBus, *wSlotDevice)**

- wBoardNo=0 to N → totally N+1 boards found by PIO_DriverInit(...)
- wBase → base address of the board control word
- wIrq → allocated IRQ channel number of this board
- wSubVendor → subVendor ID of this board
- wSubDevice → subDevice ID of this board
- **wSubAux** → **don't care this variable for PISO-725**
- wSlotBus → hardware slot ID1 of this board
- wSlotDevice → hardware slot ID2 of this board

The user can use this function to save resource of all PIO/PISO cards installed in this system. Then the application program can control all functions of PIO/PISO series card directly.

The sample program source is given as following:

```
/* step1: detect all PISO-725 cards first */
wSubVendor=0x80; wSubDevice=0x0C; wSubAux=0xff; /* for PISO-725 */
wRetVal=PIO_DriverInit(&wBoards, wSubVendor,wSubDevice,wSubAux);
printf("Threr are %d PISO-725 Cards in this PC\n",wBoards);

/* step2: save resource of all PISO-725 cards installed in this PC */
for (i=0; i<wBoards; i++)
{
  PIO_GetConfigAddressSpace(i,&wBase,&wIrq,&t1,&t2,&t3,&t4,&t5);
  printf("\nCard_ %d: wBase=%x, wIrq=%x", i,wBase,wIrq);
  wConfigSpace[i][0]=wBaseAddress; /* save all resource of this card */
  wConfigSpace[i][1]=wIrq; /* save all resource of this card */
}
/* step3: control the PISO-725 directly */
wBase=wConfigSpace[0][0];/* get base address the card_0 */
outport(wBase,1); /* enable all D/I/O operation of card_0 */

wBase=wConfigSpace[1][0];/* get base address the card_1 */
outport(wBase,1); /* enable all D/I/O operation of card_1 */
```

3.1.3 Show_PIO_PISO

Show_PIO_PISO(wSubVendor,wSubDevice,wSubAux)

- wSubVendor → subVendor ID of board to find
- wSubDevice → subDevice ID of board to find
- **wSubAux → set this variable to 0xff for PISO-725**

This function will show a text string for this special subIDs. This text string is the same as that defined in PIO.H

The demo program is given as following:

```
wRetVal=PIO_DriverInit(&wBoards,0xff,0xff,0xff); /*find all PIO_PISO*/
printf("\nThrer are %d PIO_PISO Cards in this PC",wBoards);
if (wBoards==0 ) exit(0);

printf("\n-----");
for(i=0; i<wBoards; i++)
{
    PIO_GetConfigAddressSpace(i, &wBase, &wIrq, &wSubVendor,
    &wSubDevice, &wSubAux, &wSlotBus, &wSlotDevice);

    printf("\nCard_%d:wBase=%x,wIrq=%x,subID=[%x,%x,%x],
    SlotID=[%x,%x]", i, wBase, wIrq, wSubVendor, wSubDevice,
    wSubAux, wSlotBus, wSlotDevice);

    printf(" --> ");
    ShowPioPiso(wSubVendor, wSubDevice, wSubAux);
}
```

3.2 The Assignment of I/O Address

The plug & play BIOS will assign the proper I/O address to PIO/PISO series card. If there is only one PIO/PISO board, the user can identify the board as card_0. If there are two PIO/PISO boards in the system, the user will be very difficult to identify which board is card_0 ? The software driver can support 16 boards max. Therefore the user can install 16 boards of PIO/PSIO series in one PC system. How to find the card_0 & card_1 ?

It is difficult to find the card NO. The simplest way to identify which card is card_0 is to use wSlotBus & wSlotDevice as following:

1. Remove all PISO-725 from this PC
2. Install one PISO-725 into the PC's PCI_slot1,
run PIO_PISO.EXE & record the wSlotBus1 & wSlotDevice1
3. Remove all PISO-725 from this PC
4. Install one PISO-725 into the PC's PCI_slot2,
run PIO_PISO.EXE & record the wSlotBus2 & wSlotDevice2
5. repeat (3) & (4) for all PCI_slot?, record all wSlotBus? & wSlotDevice?

The records may be as following:

PC's PCI slot	WslotBus	wSlotDevice
Slot_1	0	0x07
Slot_2	0	0x08
Slot_3	0	0x09
Slot_4	0	0x0A
PCI-BRIDGE		
Slot_5	1	0x0A
Slot_6	1	0x08
Slot_7	1	0x09
Slot_8	1	0x07

The above procedure will record all wSlotBus? & wSlotDevice? in this PC. These values will be mapped to this PC's physical slot. This mapping will not be changed for any PIO/PISO cards. So it can be used to identify the specified PIO/PISO card as following:

Step1: Record all wSlotBus? & wSlotDevice?

Step2: Use PIO_GetConfigAddressSpace(...) to get the specified card's wSlotBus & wSlotDevice

Step3: The user can identify the specified PIO/PISO card if he compare the wSlotBus & wSlotDevice in step2 to step1.

3.3 The I/O Address Map

The I/O address of PIO / PISO series card is automatically assigned by the main board ROM BIOS. The I/O address can also be re-assigned by user. **It is strongly recommended not to change the I/O address by user. The plug&play BIOS will assign proper I/O address to each PIO/PISO series card very well.** The I/O address of PISO-725 are given as following:

Address	Read	Write
wBase+0	RESET\ control register	Same
wBase+2	Aux control register	Same
wBase+3	Aux data register	Same
wBase+5	INT mask control register	Same
wBase+7	Aux pin status register	Same
wBase+0x2a	INT polarity control register	Same
wBase+0xc0	Read Back of DO0 ~ DO7 (inverse of DO0 ~ DO7)	DO0~DO7
wBase+0xc4	DI0 ~ DI7	N/A

Note. Refer to Sec. 3.1 for more information about wBase.

3.3.1 RESET\ Control Register

(Read/Write): wBase+0

Bit 7	Bit 6	Bit 5	Bit 4	Bit 3	Bit 2	Bit 1	Bit 0
Reserved	Reserved	Reserved	Reserved	Reserved	Reserved	Reserved	RESET\

Note. Refer to Sec. 3.1 for more information about wBase.

When the PC is first power-up, the RESET\ signal is in Low-state. **This will disable all D/I/O operations.** The user has to set the RESET\ signal to High-state before any D/I/O command.

```
outportb(wBase,1);          /* RESET\ = High → all D/I/O are enable now */
outportb(wBase,0);         /* RESET\ = Low  → all D/I/O are disable now */
```

3.3.2 AUX Control Register

(Read/Write): wBase+2

Bit 7	Bit 6	Bit 5	Bit 4	Bit 3	Bit 2	Bit 1	Bit 0
Aux7	Aux6	Aux5	Aux4	Aux3	Aux2	Aux1	Aux0

Note. Refer to Sec. 3.1 for more information about wBase.

Aux?=0 → this Aux is used as a D/I

Aux?=1 → this Aux is used as a D/O

When the PC is first power-on, All Aux? signal are in Low-state. All Aux? are designed as D/I for all PIO/PISO series. **Don't change this register.**

3.3.3 AUX data Register

(Read/Write): wBase+3

Bit 7	Bit 6	Bit 5	Bit 4	Bit 3	Bit 2	Bit 1	Bit 0
Aux7	Aux6	Aux5	Aux4	Aux3	Aux2	Aux1	Aux0

Note. Refer to Sec. 3.1 for more information about wBase.

When the Aux? is used as D/O, the output state is controlled by this register. This register is designed for feature extension, so **don't change this register.**

3.3.4 INT Mask Control Register

(Read/Write): wBase+5

Bit 7	Bit 6	Bit 5	Bit 4	Bit 3	Bit 2	Bit 1	Bit 0
EN7	EN6	EN5	EN4	EN3	EN2	EN1	EN0

Note. Refer to Sec. 3.1 for more information about wBase.

EN0/1/2/3/4/5/6/7=0 → disable INT_CHAN_0/1/2/3/4/5/6/7 as a interrupt signal (default)

EN0/1/2/3/4/5/6/7=1 → enable INT_CHAN_0/1/2/3/4/5/6/7 as a interrupt signal

```
outputb(wBase+5,0);      /* disable all interrupts      */
outputb(wBase+5,1);      /* enable interrupt of INT_CHAN_0 */
outputb(wBase+5,2);      /* enable interrupt of INT_CHAN_1 */
outputb(wBase+5,4);      /* enable interrupt of INT_CHAN_2 */
outputb(wBase+5,8);      /* enable interrupt of INT_CHAN_3 */
outputb(wBase+5,0x10);   /* enable interrupt of INT_CHAN_4 */
outputb(wBase+5,0x20);   /* enable interrupt of INT_CHAN_5 */
outputb(wBase+5,0x40);   /* enable interrupt of INT_CHAN_6 */
outputb(wBase+5,0x80);   /* enable interrupt of INT_CHAN_7 */
outputb(wBase+5,0xff);   /* enable all two channels of interrupt */
```

Refer to the following demo program for more information:

DEMO3.C → for INT_CHAN_0 only (initial high state)

DEMO4.C → for INT_CHAN_0 only (initial low state)

DEMO5.C → for multi-channel interrupt source

3.3.5 Aux Status Register

(Read/Write): wBase+7

Bit 7	Bit 6	Bit 5	Bit 4	Bit 3	Bit 2	Bit 1	Bit 0
Aux7	Aux6	Aux5	Aux4	Aux3	Aux2	Aux1	Aux0

Note. Refer to Sec. 3.1 for more information about wBase.

Aux0=INT_CHAN_0, Aux1=INT_CHAN_1,, Aux7=INT_CHAN_7. The Aux0~7 are used as interrupt sources. The interrupt service routine has to read this register for interrupt source identification. Refer to Sec. 2.3 for more information.

3.3.6 Interrupt Polarity Control Register

(Read/Write): wBase+0x2A

Bit 7	Bit 6	Bit 5	Bit 4	Bit 3	Bit 2	Bit 1	Bit 0
INV7	INV6	INV5	INV4	INV3	INV2	INV1	INV0

Note. Refer to Sec. 3.1 for more information about wBase.

INV0/1/2/3/4/5/6/7=0 → select the invert signal from INT_CHAN_0/1/2/3/4/5/6/7

INV0/1/2/3/4/5/6/7=1 → select the non-invert signal from INT_CHAN_0/1/2/3/4/5/6/7

outportb(wBase+0x2a,0); /* select the invert input from all 8 channels */

outportb(wBase+0x2a,0x3); /* select the non-invert input from all 8 channels */

outportb(wBase+0x2a,0x2); /* select the inverted input of INT_CHAN_0/2/3/4/5/6/7 */

/* select the non-inverted input of INT_CHAN_1 */

Refer to Sec. 2.3 for more information.

Refer to DEMO3.C, DEMO4.C, DEMO5.C & DEMO6.C for more information.

3.3.7 I/O Data Register

(Write): wBase+0xc0 → write to DO0 ~ DO7

Bit 7	Bit 6	Bit 5	Bit 4	Bit 3	Bit 2	Bit 1	Bit 0
DO7	DO6	DO5	DO4	DO3	DO2	DO1	DO0

Note. Refer to Sec. 3.1 for more information about wBase.

outportb(wBase+0xc0,0xff); /* write 0xff to DO0~DO7 */

(Read): wBase+0xc0 → DO0 ~ DO7 read back (**inverse**)

Bit 7	Bit 6	Bit 5	Bit 4	Bit 3	Bit 2	Bit 1	Bit 0
!DO7	!DO6	!DO5	!DO4	!DO3	!DO2	!DO1	!DO0

Note. Refer to Sec. 3.1 for more information about wBase.

DoReadBack=inportb(wBase+0xc0) ^ 0xff; /* DO0~DO7 read back */

NOTE: the read back data is inversed of DO0 ~ DO7. So the software driver has to inverse the data again to get the original DO0 ~ DO7.

(Read): wBase+0xc4 → read DI0 ~ DI7

Bit 7	Bit 6	Bit 5	Bit 4	Bit 3	Bit 2	Bit 1	Bit 0
DI7	DI6	DI5	DI4	DI3	DI2	DI1	DI0

Note. Refer to Sec. 3.1 for more information about wBase.

DI=inportb(wBase+0xc4); /* read DI0~DI7 */

4. Demo Program

It is recommended to read the release note first. All important information will be given in release note as following:

1. where you can find the software driver & utility
- 2. how to install software & utility**
3. where is the diagnostic program
4. FAQ

There are many demo programs given in the company floppy disk or CD. After the software installation, the driver will be installed into disk as following:

- \TC*. * → for Turbo C 2.xx or above
- \MSC*. * → for MSC 5.xx or above
- \BC*. * → for BC 3.xx or above

- \TC\LIB*. * → for TC library
- \TC\DEMO*. * → for TC demo program
- \TC\DIAG*. * → for TC diagnostic program

- \TC\LIB\Large*. * → TC large model library
- \TC\LIB\Huge*. * → TC huge model library
- \TC\LIB\Large\PIO.H → TC declaration file
- \TC\LIB\Large\TCPIO_L.LIB → TC large model library file
- \TC\LIB\Huge\PIO.H → TC declaration file
- \TC\LIB\Huge\TCPIO_H.LIB → TC huge model library file

- \MSC\LIB\Large\PIO.H → MSC declaration file
- \MSC\LIB\Large\MSCPIO_L.LIB → MSC large model library file
- \MSC\LIB\Huge\PIO.H → MSC declaration file
- \MSC\LIB\Huge\MSCPIO_H.LIB → MSC huge model library file

- \BC\LIB\Large\PIO.H → BC declaration file
- \BC\LIB\Large\BCPIO_L.LIB → BC large model library file
- \BC\LIB\Huge\PIO.H → BC declaration file
- \BC\LIB\Huge\BCPIO_H.LIB → BC huge model library file

NOTE: The library is available for all PIO/PISO series cards.

4.1 PIO_PISO

```
/* ----- */
/* Find all PIO_PISO series cards in this PC system */
/* step 1 : plug all PIO_PISO cards into PC */
/* step 2 : run PIO_PISO.EXE */
/* ----- */

#include "PIO.H"
WORD wBase,wIrq;
WORD wBase2,wIrq2;

int main()
{
int i,j,j1,j2,j3,j4,k,jj,dd,j11,j22,j33,j44;
WORD wBoards,wRetVal;
WORD wSubVendor,wSubDevice,wSubAux,wSlotBus,wSlotDevice;
char c;
float ok,err;

clrscr();
printf("\n*** PIO_PISO.EXE Rev. 2.0 ***\n\n");

wRetVal=PIO_DriverInit(&wBoards,0xff,0xff,0xff); /*for PIO-PISO*/
printf("\nThrer are %d PIO_PISO Cards in this PC",wBoards);
if (wBoards==0 ) exit(0);

printf("\n-----");
for(i=0; i<wBoards; i++)
{
PIO_GetConfigAddressSpace(i,&wBase,&wIrq,&wSubVendor,
&wSubDevice,&wSubAux,&wSlotBus,&wSlotDevice);

if ((wSubVendor==0x80)&&(wSubDevice==0x0C)) /* for PISO-725 */
printf("\nCard_%d:wBase=%x,wIrq=%x,subID=[%x,%x], SlotID=[%x,%x]",
i,wBase,wIrq,wSubVendor,wSubDevice,wSlotBus,wSlotDevice);
else /* for the other PIO_PISO series cards */
printf("\nCard_%d:wBase=%x,wIrq=%x,subID=[%x,%x,%x], SlotID=[%x,%x]",
i,wBase,wIrq,wSubVendor,wSubDevice,wSubAux,wSlotBus,wSlotDevice);

printf(" --> ");
ShowPioPiso(wSubVendor,wSubDevice,wSubAux);
}

PIO_DriverClose();
}
```

NOTE: the PIO_PISO.EXE is valid for all PIO/PISO cards. It can be find in the \TC\DIAG\ directory. The user can execute the PIO_PISO.EXE to get the following information:

- List all PIO/PISO cards installed in this PC
- List all resources allocated to every PIO/PISO cards
- List the wSlotBus & wSlotDevice for specified PIO/PISO card identification. (refer to Sec. 3.2 for more information)

4.1.1 PIO_PISO.EXE for Windows

There is an software utility “PIO_PISO.EXE” for Windows95/98 for the detailed information about this file, please refer to the “Readme.txt” of development toolkit for Windows95/98. It is useful for all PIO/PIS series card.

The setup steps from the CD-ROM are given as following:

- Step1: Toolkit(Software)/Manuals
- Step2: I Agree
- Step3: PCI Bus DAQ Card
- Step4: PIO_PISO
- Step5: Install Toolkits for Windows95/98
- Step6: After installation, this program will be extracted in user define directory.

After executing the utility, every detail information for all PIO/PISO cards that installed in the PC will be shown as following:

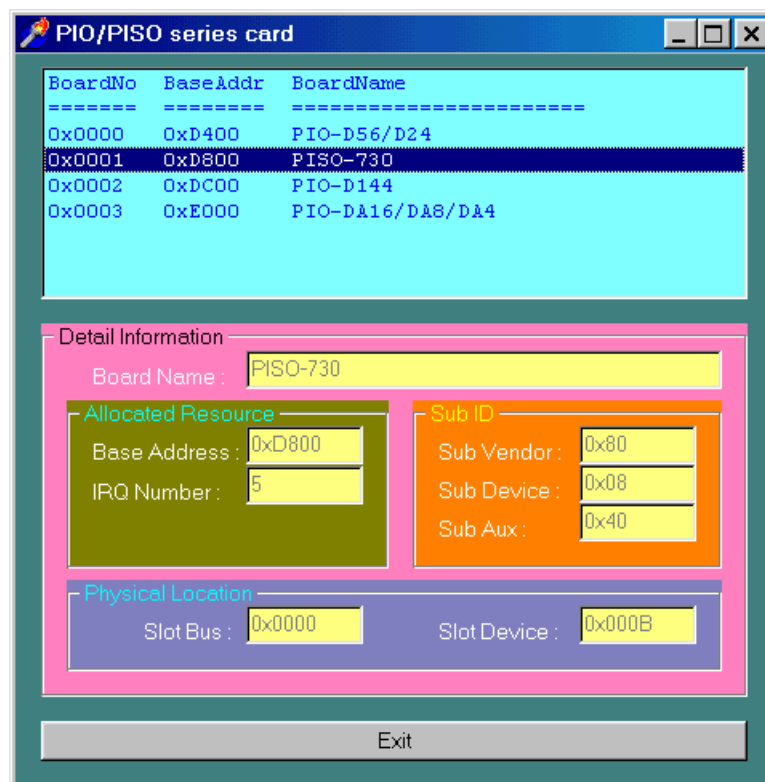

4.2 DEMO1: D/O Demo

```
/* ----- */
/* DEMO1.C : PISO-725 D/O demo */
/* step 1 : run DEMO1.EXE */
/* ----- */
#include "PIO.H"
void piso_725_do(char DO);
char piso_725_do_readback(void);
WORD wBase,wIrq;

int main()
{
int i,j,k1,k2,l1,l2,jj,dd,j1,i1,j2,i2;
WORD wBoards,wRetVal,t1,t2,t3,t4,t5;
WORD wSubVendor,wSubDevice,wSubAux,wSlotBus,wSlotDevice;
char c,DO,ReadBack;

clrscr();
/* step 1: find address-mapping of PIO/PISO cards */
wRetVal=PIO_DriverInit(&wBoards,0x80,0x0C,0xff); /* for PISO-725 */
printf("\nThrer are %d PISO-725 Cards in this PC",wBoards);
if (wBoards==0) exit(0);

printf("\n----- The Configuration Space -----");
for(i=0; i<wBoards; i++)
{
PIO_GetConfigAddressSpace(i,&wBase,&wIrq,&wSubVendor,&wSubDevice,
&wSubAux,&wSlotBus,&wSlotDevice);
printf("\nCard_%d: wBase=%x,wIrq=%x,subID=[%x,%x],SlotID=[%x,%x]"
,i,wBase,wIrq,wSubVendor,wSubDevice,wSlotBus,wSlotDevice);
printf(" --> ");
ShowPioPiso(wSubVendor,wSubDevice,wSubAux);
}

PIO_GetConfigAddressSpace(0,&wBase,&wIrq,&t1,&t2,&t3,&t4,&t5);

/* step 2: enable all D/I/O port */
outportb(wBase,1); /* enable D/I/O */

printf("\n\n");
DO=1;
for(;;)
{
gotoxy(1,6);
piso_725_do(DO);
printf("\nOutput DO[0..7] = [%2x]",DO&0xff);

delay(12000);
gotoxy(1,7);
ReadBack=piso_725_do_readback();
printf("\nReadBack DO[0..7] = [%2x]",ReadBack&0xff);

delay(12000);
DO=DO<<1; if (DO==0) DO=1;

if (kbhit()!=0) break;
}
}
```

```

PIO_DriverClose();
}

/* ----- */

void piso_725_do(char DoValue)
{
outportb(wBase+0xc0,DoValue);
}

/* ----- */

char piso_725_do_readback(void)
{
return(inportb(wBase+0xc0) ^ 0xff);
}

```

4.3 DEMO2: D/I/O Demo

```
/* ----- */
/* DEMO2.C : PISO-725 D/I/O demo */
/* step 1 : run DEMO2.EXE */
/* ----- */
#include "PIO.H"
void piso_725_do(char DoValue);
char piso_725_do_readback(void);
char piso_725_di(void);
WORD wBase,wIrq;

int main()
{
int i,j,k,k1,k2,l1,l2,jj,dd,j1,i1,j2,i2;
WORD wBoards,wRetVal,t1,t2,t3,t4,t5;
WORD wSubVendor,wSubDevice,wSubAux,wSlotBus,wSlotDevice;
long lOutPad1,lOutPad2,lInPad1,lInPad2;
char c,DI,DO,ReadBack;

clrscr();
/* step 1: find address-mapping of PIO/PISO cards */
.
.
/* step 2: enable all D/I/O port */
outportb(wBase,1); /* enable D/I/O */

printf("\n\n");
DO=1;
for(;;)
{
gotoxy(1,6);
piso_725_do(DO);
printf("\nOutput DO[0..7] = [%2x]",DO&0xff);

delay(12000);
gotoxy(1,7);
ReadBack=piso_725_do_readback();
printf("\nReadBack DO[0..7] = [%2x]",ReadBack&0xff);

gotoxy(1,9);
DI=piso_725_di();
printf("\nInput DI[0..7] = [%2x]",DI&0xff);

delay(12000);
DO=DO<<1; if (DO==0) DO=1;
if (kbhit()!=0) break;
}
PIO_DriverClose();
}

/* ----- */

char piso_725_di(void)
{
return(inportb(wBase+0xc4));
}
```

4.4 DEMO3: Init_High, Active_Low

```
/* ----- */
/* DEMO3.C : PISO-725 Interrupt (DIO initial high) */
/* step 1 : DIO to function generator */
/* step 2 : run DEMO3.EXE */
/* ----- */
#include "PIO.H"
#define A1_8259 0x20
#define A2_8259 0xA0
#define EOI 0x20

WORD init_high();
void interrupt (*oldfunc) ();
static void interrupt irq_service();
int COUNT_L,COUNT_H,irqmask,now_int_state;

WORD wBase,wIrq;

int main()
{
int i,j,k,k1,k2,l1,l2,jj,dd,j1,i1,j2,i2;
WORD wBoards,wRetVal,t1,t2,t3,t4,t5;
WORD wSubVendor,wSubDevice,wSubAux,wSlotBus,wSlotDevice;
char c;

clrscr();
/* step 1: find address-mapping of PIO/PISO cards */
.
.
/* step 2: enable all D/I/O port */
outportb(wBase,1); /* enable D/I/O */

init_high();

printf("\n\n***** show the count of Low_pulse *****\n");
for(;;)
{
gotoxy(1,8);
printf("\nCOUNT_L=[%5d]",COUNT_L);
if (kbhit()!=0) break;
}

disable();

outportb(wBase+5,0); /* disable all interrupt */
if (wIrq<8)
{
setvect(wIrq+8,oldfunc);
}
else
{
setvect(wIrq-8+0x70,oldfunc);
}
PIO_DriverClose();
}
```

```

WORD init_high()
{
DWORD dwVal;

disable();
outportb(wBase+5,0);          /* disable all interrupt */

if (wIrq<8)
{
oldfunc=getvect(wIrq+8);
irqmask=inportb(A1_8259+1);
outportb(A1_8259+1,irqmask & (0xff ^ (1 << wIrq)));
setvect(wIrq+8, irq_service);
}
else
{
oldfunc=getvect(wIrq-8+0x70);
irqmask=inportb(A1_8259+1);
outportb(A1_8259+1,irqmask & 0xfb);          /* IRQ2 */
irqmask=inportb(A2_8259+1);
outportb(A2_8259+1,irqmask & (0xff ^ (1 << (wIrq-8))));
setvect(wIrq-8+0x70, irq_service);
}

outportb(wBase+0x2a,0);          /* invert DIO */

now_int_state=0x1;          /* now DIO is high */
outportb(wBase+5,0x1);          /* enable DIO interrupt */
enable();
}

/* ----- */

void interrupt irq_service()
{
if (now_int_state==1)          /* now DIO change to low */
{
/* INT_CHAN_0 = !DIO */
COUNT_L++;          /* find a low pulse (DIO) */
if ((inportb(wBase+7)&1)==0) /* DIO still fixed in low */
{
/* need to generate a high pulse */
outportb(wBase+0x2a,1); /* INVO select noninverted input */
now_int_state=0;          /* now DIO=low */
}
else now_int_state=1;          /* now DIO=High */
}
else          /* now DIO change to high */
{
/* INT_CHAN_0 = DIO */
COUNT_H++;          /* find a high pulse (DIO) */
if ((inportb(wBase+7)&1)==1) /* DIO still fixed in high */
{
/* need to generate a high pulse */
outportb(wBase+0x2a,0); /* INVO select inverted input */
now_int_state=1;          /* now DIO=high */
}
else now_int_state=0;          /* now DIO=low */
}
if (wIrq>=8) outportb(A2_8259,0x20);
outportb(A1_8259,0x20);
}

```

4.5 DEMO4: Init_Low, Active_High

```
/* ----- */
/* DEMO4.C : PISO-725 Interrupt (DIO initial low) */
/* step 1 : DIO to function generator */
/* step 2 : run DEMO4.EXE */
/* ----- */
#include "PIO.H"

#define A1_8259 0x20
#define A2_8259 0xA0
#define EOI 0x20

WORD init_low();
void interrupt (*oldfunc) ();
static void interrupt irq_service();
int COUNT_L,COUNT_H,irqmask,now_int_state;

WORD wBase,wIrq;

int main()
{
int i,j,k,k1,k2,l1,l2,jj,dd,j1,i1,j2,i2;
WORD wBoards,wRetVal,t1,t2,t3,t4,t5;
WORD wSubVendor,wSubDevice,wSubAux,wSlotBus,wSlotDevice;
char c;

clrscr();
/* step 1: find address-mapping of PIO/PISO cards */
.
.
/* step 2: enable all D/I/O port */
outportb(wBase,1); /* enable D/I/O */

init_Low();

printf("\n\n***** show the count of High_pulse *****\n");
for(;;)
{
gotoxy(1,8);
printf("\nCOUNT_H=[%5d]",COUNT_H);
if (kbhit()!=0) break;
}
disable();
outportb(wBase+5,0); /* disable all interrupt */
if (wIrq<8)
{
setvect(wIrq+8,oldfunc);
}
else
{
setvect(wIrq-8+0x70,oldfunc);
}
PIO_DriverClose();
}
```

```

WORD init_low()
{
DWORD dwVal;

disable();
outportb(wBase+5,0);          /* disable all interrupt */

if (wIrq<8)
{
oldfunc=getvect(wIrq+8);
irqmask=inportb(A1_8259+1);
outportb(A1_8259+1,irqmask & (0xff ^ (1 << wIrq)));
setvect(wIrq+8, irq_service);
}
else
{
oldfunc=getvect(wIrq-8+0x70);
irqmask=inportb(A1_8259+1);
outportb(A1_8259+1,irqmask & 0xfb);          /* IRQ2 */
irqmask=inportb(A2_8259+1);
outportb(A2_8259+1,irqmask & (0xff ^ (1 << (wIrq-8))));
setvect(wIrq-8+0x70, irq_service);
}
outportb(wBase+0x2a,1);          /* non-invert DIO */
now_int_state=0x0;          /* now DIO is low */
outportb(wBase+5,0x1);          /* enable DIO interrupt */
enable();
}

/* ----- */

void interrupt irq_service()
{
if (now_int_state==1)          /* now DIO change to low */
{
/* INT_CHAN_0 = !DIO */
COUNT_L++;          /* find a low pulse (DIO) */
if ((inportb(wBase+7)&1)==0) /* DIO still fixed in low */
{
/* need to generate a high pulse */
outportb(wBase+0x2a,1); /* INVO select noninverted input */
now_int_state=0;          /* now DIO=low */
}
else now_int_state=1;          /* now DIO=High */
}
else          /* now DIO change to high */
{
/* INT_CHAN_0 = DIO */
COUNT_H++;          /* find a high pulse (DIO) */
if ((inportb(wBase+7)&1)==1) /* DIO still fixed in high */
{
/* need to generate a high pulse */
outportb(wBase+0x2a,0); /* INVO select inverted input */
now_int_state=1;          /* now DIO=high */
}
else now_int_state=0;          /* now DIO=low */
}
if (wIrq>=8) outportb(A2_8259,0x20);
outportb(A1_8259,0x20);
}

```

4.6 DEMO5: 2-Channel Interrupt

```
/* DEMO5.C : PISO-725 Interrupt (Multi interrupt source) */
/*          DIO : initial low , DI1 : initial high      */
/* step 1   : connect DIO & DI1 to function generator  */
/* step 2   : run DEMO5.EXE                            */
/* ----- */
#include "PIO.H"

#define A1_8259 0x20
#define A2_8259 0xA0
#define EOI     0x20

WORD init();
void interrupt (*oldfunc) ();
static void interrupt irq_service();
int  irqmask,now_int_state,new_int_state,invert,int_c,int_num;
int  CNT_L1,CNT_L2,CNT_H1,CNT_H2;

WORD wBase,wIrq;

int main()
{
  int i,j,k;
  WORD wBoards,wRetVal,t1,t2,t3,t4,t5;
  WORD wSubVendor,wSubDevice,wSubAux,wSlotBus,wSlotDevice;
  char c;

  clrscr();
  /* step 1: find address-mapping of PIO/PISO cards */
  .
  .
  /* step 2: enable all D/I/O port */
  outportb(wBase,1); /* enable D/I/O */
  init();
  printf("\n\n***** show the count of High_pulse *****\n");
  for(;;)
  {
    gotoxy(1,8);
    printf("\nCNT_L1,CNT_L2=[%5d,%5d]",CNT_L1,CNT_L2);
    printf("\nCNT_H1,CNT_H2=[%5d,%5d]",CNT_H1,CNT_H2);
    if (kbhit()!=0) break;
  }
  disable();
  outportb(wBase+5,0); /* disable all interrupt */
  if (wIrq<8)
  {
    setvect(wIrq+8,oldfunc);
  }
  else
  {
    setvect(wIrq-8+0x70,oldfunc);
  }
  PIO_DriverClose();
}
/* ----- */
WORD init()
{
  DWORD dwVal;
  disable();
```

```

outportb(wBase+5,0); /* disable all interrupt */
if (wIrq<8)
{
    oldfunc=getvect(wIrq+8);
    irqmask=inportb(A1_8259+1);
    outportb(A1_8259+1,irqmask & (0xff ^ (1 << wIrq)));
    setvect(wIrq+8, irq_service);
}
else
{
    oldfunc=getvect(wIrq-8+0x70);
    irqmask=inportb(A1_8259+1);
    outportb(A1_8259+1,irqmask & 0xfb); /* IRQ2 */
    irqmask=inportb(A2_8259+1);
    outportb(A2_8259+1,irqmask & (0xff ^ (1 << (wIrq-8))));
    setvect(wIrq-8+0x70, irq_service);
}
invert=0x1;
outportb(wBase+0x2a,invert); /* non-invert DIO */
/* invert DI1 */
now_int_state=0x2; /* now DIO is low */
/* now DI1 is high */
outportb(wBase+5,0x3); /* enable all interrupt */
enable();
}
/* ----- */
void interrupt irq_service()
{
    int_num++;
    new_int_state=inportb(wBase+7)&0x3;
    int_c=new_int_state^now_int_state;
    if ((int_c&0x1)!=0) /* now INT_CHAN_0 change to high */
    {
        if ((new_int_state&0x01)!=0)
        {
            CNT_H1++;
        }
        else /* now INT_CHAN_0 change to low */
        {
            CNT_L1++;
        }
        invert=invert^1; /* generate a high pulse */
    }
    if ((int_c&0x2)!=0) /* now INT_CHAN_1 change to high */
    {
        if ((new_int_state&0x02)!=0)
        {
            CNT_H2++;
        }
        else /* now INT_CHAN_1 change to low */
        {
            CNT_L2++;
        }
        invert=invert^2; /* generate a high pulse */
    }
    now_int_state=new_int_state;
    outportb(wBase+0x2a,invert);
    if (wIrq>=8) outportb(A2_8259,0x20);
    outportb(A1_8259,0x20);
}

```

4.7 DEMO6: 8-Channel Interrupt

```
/* ----- */
/* DEMO6.C : PISO-725 Interrupt (Multi interrupt source) */
/*          DI0/2/4/5: initial low ,          DI1/3/6/7 : initial high*/
/* step 1  : connect DI0/1/2/3/4/5/6/7      to external signals */
/* step 2  : run DEMO6.EXE */
/* ----- */
#include "PIO.H"

#define A1_8259 0x20
#define A2_8259 0xA0
#define EOI 0x20

WORD init();
void interrupt (*oldfunc) ();
static void interrupt irq_service();
int  irqmask,now_int_state,new_int_state,invert,int_c,int_num;
int  CNT_L1,CNT_H1,CNT_L2,CNT_H2;
int  CNT_L3,CNT_H3,CNT_L4,CNT_H4;
int  CNT_L5,CNT_H5,CNT_L6,CNT_H6;
int  CNT_L7,CNT_H7,CNT_L8,CNT_H8;

WORD wBase,wIrq;

int main()
{
int  i,j,k;
WORD wBoards,wRetVal,t1,t2,t3,t4,t5;
WORD wSubVendor,wSubDevice,wSubAux,wSlotBus,wSlotDevice;
char c;

clrscr();
/* step 1: find address-mapping of PIO/PISO cards */
:
:

/* step 2: enable all D/I/O port */
outportb(wBase,1);          /* enable D/I/O */

CNT_L1=CNT_L2=CNT_L3=CNT_L4=CNT_L5=CNT_L6=CNT_L7=CNT_L8=0;
CNT_H1=CNT_H2=CNT_H3=CNT_H4=CNT_H5=CNT_H6=CNT_H7=CNT_H8=0;
init();

printf("\n\n***** show the count of High_pulse & Low_pulse *****\n");
for(;;)
{
gotoxy(1,8);
printf("\nCNT_L1/2/3/4/5/6/7/8=[%5d,%5d,%5d,%5d,%5d,%5d,%5d,%5d]",
CNT_L1,CNT_L2,CNT_L3,CNT_L4,CNT_L5,CNT_L6,CNT_L7,CNT_L8);
printf("\nCNT_H1/2/3/4/5/6/7/8=[%5d,%5d,%5d,%5d,%5d,%5d,%5d,%5d]",
CNT_H1,CNT_H2,CNT_H3,CNT_H4,CNT_H5,CNT_H6,CNT_H7,CNT_H8);
if (kbhit()!=0) break;
}

disable();
```

```

outportb(wBase+5,0);          /* disable all interrupt */
if (wIrq<8)
{
    setvect(wIrq+8,oldfunc);
}
else
{
    setvect(wIrq-8+0x70,oldfunc);
}
PIO_DriverClose();
}

/* ----- */

WORD init()
{
DWORD dwVal;

disable();
outportb(wBase+5,0);        /* disable all interrupt */

if (wIrq<8)
{
    oldfunc=getvect(wIrq+8);
    irqmask=inportb(A1_8259+1);
    outportb(A1_8259+1,irqmask & (0xff ^ (1 << wIrq)));
    setvect(wIrq+8, irq_service);
}
else
{
    oldfunc=getvect(wIrq-8+0x70);
    irqmask=inportb(A1_8259+1);
    outportb(A1_8259+1,irqmask & 0xfb);          /* IRQ2 */
    irqmask=inportb(A2_8259+1);
    outportb(A2_8259+1,irqmask & (0xff ^ (1 << (wIrq-8))));
    setvect(wIrq-8+0x70, irq_service);
}

invert=0x35;
outportb(wBase+0x2a,invert); /* non-invert  DI0/2/4/5    */
                             /*      invert  DI1/3/6/7    */
                             /*      00110101    */
now_int_state=0xCA;         /* now  DI0/2/4/5 = low  */
                             /* now  DI1/3/6/7 = high */
                             /*      11001010    */
outportb(wBase+5,0xFF);    /* enable all interrupt  */
enable();
}

```

```

void interrupt irq_service()
{
int_num++;

new_int_state=inportb(wBase+7)&0xFF;
int_c=new_int_state^now_int_state;

if ((int_c&0x1)!=0)      +      /* now INT_CHAN_0 change to high */
{
if ((new_int_state&0x01)!=0)
{
CNT_H1++;
}
else      /* now INT_CHAN_0 change to low */
{
CNT_L1++;
}
invert=invert^1;      /* generate a high pulse      */
}

if ((int_c&0x2)!=0)      /* now INT_CHAN_1 change to high */
{
if ((new_int_state&0x02)!=0)
{
CNT_H2++;
}
else      /* now INT_CHAN_1 change to low */
{
CNT_L2++;
}
invert=invert^2;      /* generate a high pulse      */
}

if ((int_c&0x4)!=0)      /* now INT_CHAN_2 change to high */
{
if ((new_int_state&0x04)!=0)
{
CNT_H3++;
}
else      /* now INT_CHAN_2 change to low */
{
CNT_L3++;
}
invert=invert^4;      /* generate a high pulse      */
}

if ((int_c&0x8)!=0)      /* now INT_CHAN_3 change to high */
{
if ((new_int_state&0x08)!=0)
{
CNT_H4++;
}
else      /* now INT_CHAN_3 change to low */
{
CNT_L4++;
}
invert=invert^8;      /* generate a high pulse      */
}
}

```

```

if ((int_c&0x10)!=0)          /* now INT_CHAN_4 change to high */
{
    if ((new_int_state&0x10)!=0)
    {
        CNT_H5++;
    }
    else                          /* now INT_CHAN_4 change to low */
    {
        CNT_L5++;
    }
    invert=invert^0x10;        /* generate a high pulse      */
}

if ((int_c&0x20)!=0)          /* now INT_CHAN_5 change to high */
{
    if ((new_int_state&0x20)!=0)
    {
        CNT_H6++;
    }
    else                          /* now INT_CHAN_5 change to low */
    {
        CNT_L6++;
    }
    invert=invert^0x20;        /* generate a high pulse      */
}

if ((int_c&0x40)!=0)          /* now INT_CHAN_6 change to high */
{
    if ((new_int_state&0x40)!=0)
    {
        CNT_H7++;
    }
    else                          /* now INT_CHAN_6 change to low */
    {
        CNT_L7++;
    }
    invert=invert^0x40;        /* generate a high pulse      */
}

if ((int_c&0x80)!=0)          /* now INT_CHAN_7 change to high */
{
    if ((new_int_state&0x80)!=0)
    {
        CNT_H8++;
    }
    else                          /* now INT_CHAN_7 change to low */
    {
        CNT_L8++;
    }
    invert=invert^0x80;        /* generate a high pulse      */
}

now_int_state=new_int_state;
outportb(wBase+0x2a,invert);

if (wIrq>=8) outportb(A2_8259,0x20);
outportb(A1_8259,0x20);
}

```